

EMC Test Report

Client Name : HOLYBRO(H.K.) LIMITED
Address : RM 1902 EASEY COMM BLDG253-261 HENNESSY RD
WANCHAI HONG KONG
Product Name : Durandal
Date : Nov. 14, 2019

Shenzhen Anbotek Compliance Laboratory Limited

Contents

| | |
|------------------------------------------------|----|
| 1. General Information..... | 5 |
| 1.1. Client Information..... | 5 |
| 1.2. Description of Device (EUT)..... | 5 |
| 1.3. Auxiliary Equipment Used During Test..... | 5 |
| 1.4. Description of Test Mode..... | 6 |
| 1.5. Test Summary..... | 6 |
| 1.6. Test Equipment List..... | 7 |
| 1.7. Description of Test Facility..... | 9 |
| 1.8. EMS Performance Criteria..... | 9 |
| 2. Power Line Conducted Emission Test..... | 10 |
| 2.1. Test Standard and Limit..... | 10 |
| 2.2. Test Setup..... | 10 |
| 2.3. EUT Configuration on Measurement..... | 10 |
| 2.4. Operating Condition of EUT..... | 10 |
| 2.5. Test Procedure..... | 11 |
| 2.6. Test Results..... | 11 |
| 3. Radiated Emission Test..... | 14 |
| 3.1. Test Standard and Limit..... | 14 |
| 3.2. Test Setup..... | 14 |
| 3.3. EUT Configuration on Measurement..... | 14 |
| 3.4. Operating Condition of EUT..... | 15 |
| 3.5. Test Procedure..... | 15 |
| 3.6. Test Results..... | 15 |
| 4.1. Test Standard..... | 18 |
| 4.2. Test Setup..... | 18 |
| 4.3. Operating Condition of EUT..... | 18 |
| 4.4. Test Results..... | 18 |
| 5. Voltage Fluctuations & Flicker Test..... | 19 |
| 5.1. Test Standard..... | 19 |
| 5.2. Test Setup..... | 19 |
| 5.3. Operating Condition of EUT..... | 19 |
| 5.4. Test Results..... | 19 |
| 6. Electrostatic Discharge Immunity Test..... | 21 |
| 6.1. Test Standard and Level..... | 21 |
| 6.2. Test Setup..... | 21 |
| 6.3. EUT Configuration on Measurement..... | 21 |
| 6.4. Operating Condition of EUT..... | 21 |
| 6.5. Test Procedure..... | 22 |
| 6.6. Test Results..... | 22 |

| | |
|-------------------------------------------------------|----|
| 7. RF Field Strength Susceptibility Test..... | 24 |
| 7.1. Test Standard and Level..... | 24 |
| 7.2. Test Setup..... | 24 |
| 7.3. EUT Configuration on Measurement..... | 25 |
| 7.4. Operating Condition of EUT..... | 25 |
| 7.5. Test Procedure..... | 25 |
| 7.6. Measuring Results..... | 25 |
| 8. Electrical Fast Transient/Burst Immunity Test..... | 27 |
| 8.1. Test Standard and Level..... | 27 |
| 8.2. Test Setup..... | 27 |
| 8.3. EUT Configuration on Measurement..... | 27 |
| 8.4. Operating Condition of EUT..... | 27 |
| 8.5. Test Procedure..... | 28 |
| 8.6. Test Results..... | 28 |
| 9. Surge Immunity Test..... | 30 |
| 9.1. Test Standard and Level..... | 30 |
| 9.2. Test Setup..... | 30 |
| 9.3. EUT Configuration on Measurement..... | 30 |
| 9.4. Operating Condition of EUT..... | 30 |
| 9.5. Test Procedure..... | 31 |
| 9.6. Test Results..... | 31 |
| 10. Injected Currents Susceptibility Test..... | 33 |
| 10.1. Test Standard and Level..... | 33 |
| 10.2. Test Setup..... | 33 |
| 10.3. EUT Configuration..... | 33 |
| 10.4. Operating Condition of EUT..... | 33 |
| 10.5. Test Procedure..... | 34 |
| 10.6. Test Results..... | 34 |
| 11. Voltage Dips And Interruptions Test..... | 36 |
| 11.1. Test Standard and Level..... | 36 |
| 11.2. Test Setup..... | 36 |
| 11.3. EUT Configuration on Measurement..... | 36 |
| 11.4. Operating Condition of EUT..... | 36 |
| 11.5. Test Procedure..... | 37 |
| 11.6. Test Results..... | 37 |
| APPENDIX I -- TEST SETUP PHOTOGRAPH..... | 39 |
| APPENDIX II -- EXTERNAL PHOTOGRAPH..... | 44 |
| APPENDIX III -- INTERNAL PHOTOGRAPH..... | 47 |

TEST REPORT

Applicant : HOLYBRO(H.K.) LIMITED
Manufacturer : Shenzhen HolyBro Hobby Technical Co., LTD
Product Name : FULL HD DVB-T2 RECEIVER
Model No. : Durandal H7, PX4
Trade Mark : Holybro
Rating(s) : Input:5V, 200mA, 1WPWM

Test Standard(s) : **EN 55032: 2015;**
EN 61000-3-2: 2014;
EN 61000-3-3: 2013;
EN 55035: 2017;
(IEC 61000-4-2; IEC 61000-4-3; IEC 61000-4-4;
IEC 61000-4-5; IEC 61000-4-6; IEC 61000-4-11)

The device described above is tested by Shenzhen Anbotek Compliance Laboratory Limited to determine the maximum emission levels emanating from the device and the severe levels of the device can endure and its performance criterion. The measurement results are contained in this test report and Shenzhen Anbotek Compliance Laboratory Limited is assumed full of responsibility for the accuracy and completeness of these measurements. Also, this report shows that the EUT (Equipment Under Test) is technically compliant with the EN 55032, EN 61000-3-2, EN 61000-3-3, EN 55035 requirements.

This report applies to above tested sample only and shall not be reproduced in part without written approval of Shenzhen Anbotek Compliance Laboratory Limited.

Date of Receipt: Oct. 22, 2019

Date of Test: Oct. 22-Nov. 06, 2019

Prepared By:

Jane Ding

(Engineer / Jane Ding)

Reviewer:

Well Wang

(Supervisor / Well Wang)

Approved & Authorized Signer:

Sally Zhang

(Manager / Sally Zhang)



1. General Information

1.1. Client Information

| | | |
|--------------|---|---------------------------------------------------------------------------------------------------------------------------------|
| Applicant | : | HOLYBRO(H.K.) LIMITED |
| Address | : | RM 1902 EASEY COMM BLDG253-261 HENNESSY RD WANCHAI HONG KONG |
| Manufacturer | : | Shenzhen HolyBro Hobby Technical Co., LTD |
| Address | : | Floor 4, Jiang Hai Industry District, No.7 yonghe Road, Shi Yan Town, Bao'an District, Shenzhen City, Guangdong Province, China |
| Factory | : | Shenzhen HolyBro Hobby Technical Co., LTD |
| Address | : | Floor 4, Jiang Hai Industry District, No.7 yonghe Road, Shi Yan Town, Bao'an District, Shenzhen City, Guangdong Province, China |

1.2. Description of Device (EUT)

| | | |
|---------------------------------------------------------------------------------------------------------------------------------------------|---|---------------------------------------------------------------------------------------------------------------------------------------|
| Product Name | : | Durandal |
| Model No. | : | Durandal H7, PX4 (Note: All samples are the same except the model number & appearance, so we prepare "Durandal H7" for test only.) |
| Trade Mark | : | Holybro |
| Test Power Supply | : | DC 5V via adapter |
| Test Sample No. | : | 1-1-1 |
| Product Description | : | Adapter: |
| <p>Remark: (1) For a more detailed features description, please refer to the manufacturer's specifications or the User's Manual.</p> | | |

1.3. Auxiliary Equipment Used During Test

| | | |
|-----|---|--|
| N/A | : | |
|-----|---|--|

1.4. Description of Test Mode

| Pretest Mode | Description |
|--------------|-------------|
| Mode 1 | On |

For Mode 1 Block Diagram of Test Setup

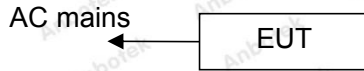

1.5. Test Summary

| Test Items | Test Mode | Status |
|------------------------------------------------------|-----------|--------|
| Power Line Conducted Emission Test (150KHz To 30MHz) | Mode 1 | P |
| Radiated Emission Test (30MHz To 1000MHz) | Mode 1 | P |
| Harmonic Current Test | / | N |
| Voltage Fluctuations and Flicker Test | Mode 1 | P |
| Electrostatic Discharge immunity Test | Mode 1 | P |
| RF Field Strength susceptibility Test | Mode 1 | P |
| Electrical Fast Transient/Burst Immunity Test | Mode 1 | P |
| Surge Immunity Test | Mode 1 | P |
| Injected Currents Susceptibility Test | Mode 1 | P |
| Magnetic Field Susceptibility Test | / | N |
| Voltage Dips and Interruptions Test | Mode 1 | P |
| P) Indicates "PASS". | | |
| N) Indicates "Not applicable". | | |

1.6. Test Equipment List

Conducted Emission Measurement

| Item | Equipment | Manufacturer | Model No. | Serial No. | Last Cal. | Cal. Interval |
|------|-----------------------------------------|-------------------------|-----------|------------|---------------|---------------|
| 1. | L.I.S.N. Artificial Mains Network | Rohde & Schwarz | ENV216 | 100055 | Nov. 04, 2019 | 1 Year |
| 2. | L.I.S.N. Artificial Mains Network | Schwarzbeck | NSLK 8127 | 8127386 | Nov. 04, 2019 | 1 Year |
| 3. | EMI Test Receiver | Rohde & Schwarz | ESCI | 100627 | Nov. 04, 2019 | 1 Year |
| 4. | RF Switching Unit | Compliance Direction | RSU-M2 | 38303 | Nov. 04, 2019 | 1 Year |
| 5. | Software Name EZ-EMC | Ferrari Technology | ANB-03A | N/A | N/A | N/A |

Radiated Emission Measurement

| Item | Equipment | Manufacturer | Model No. | Serial No. | Last Cal. | Cal. Interval |
|------|----------------------------|--------------------|-----------|------------|---------------|---------------|
| 1. | EMI Test Receiver | Rohde & Schwarz | ESCI | 100627 | Nov. 04, 2019 | 1 Year |
| 2. | Pre-amplifier | Schwarzbeck | BBV-9745 | 9745-075 | Nov. 04, 2019 | 1 Year |
| 3. | Bilog Broadband Antenna | SCHWARZBECK | VULB 9163 | 01109 | Nov. 01, 2019 | 1 Year |
| 4. | Software Name EZ-EMC | Ferrari Technology | EMEC-3A1 | N/A | N/A | N/A |

Harmonic and Flicker Measurement

| Item | Equipment | Manufacturer | Model No. | Serial No. | Last Cal. | Cal. Interval |
|------|----------------------------------|--------------|--------------------|------------|---------------|---------------|
| 1. | Programmable AC Power source | IVYTECH | APS-5005A | 632734 | Nov. 04, 2019 | 1 Year |
| 2. | Harmonic and Flicker Analyzer | EMC-PARTNER | HMONICS 1000-1P | 164 | Nov. 04, 2019 | 1 Year |
| 3. | Harmonics-1000 | N/A | Ed.3.0+4.0 | N.A | N/A | N/A |

Electrostatic Discharge Measurement

| Item | Equipment | Manufacturer | Model No. | Serial No. | Last Cal. | Cal. Interval |
|------|----------------|--------------|-----------|------------|---------------|---------------|
| 1. | ESD Simulators | 3Ctest | EDS-30T | ES0131505 | Nov. 26, 2018 | 1 Year |

Electrical Fast Transient/Burst Immunity Measurement

| Item | Equipment | Manufacturer | Model No. | Serial No. | Last Cal. | Cal. Interval |
|------|------------------------|--------------|-----------|------------|---------------|---------------|
| 1.1 | EFT Burst Simulator | PRIMA | EFT61004B | PR10114282 | Nov. 04, 2019 | 1 Year |
| 1.2 | EFT-Clamp | PRIMA | EFT-Clamp | / | Nov. 04, 2019 | 1 Year |
| 2.1 | EFT Burst Simulator | TESEQ | NSG 3060 | 1480 | Nov. 04, 2019 | 1 Year |
| 2.2 | CDN | TESEQ | CDN 3061 | 1408 | Nov. 04, 2019 | 1 Year |

R/S Immunity Measurement

| Item | Equipment | Manufacturer | Model No. | Serial No. | Last Cal. | Cal. Interval |
|------|-------------------------|----------------------------|-----------------------|----------------|---------------|---------------|
| 1 | Signal Generator | Agilent | N5182A | MY4818065 6 | Nov. 04, 2019 | 1 Year |
| 2 | Amplifier | Micotoop | MPA-80-100 0-250 | MPA190309 6 | N/A | N/A |
| 3 | Amplifier | Micotoop | MPA-1000-6 000-100 | MPA190312 2 | N/A | N/A |
| 4 | Log-Periodic Antenna | Schwarzbeck | VULP9118E | 00992 | Aug. 17, 2018 | 3 Year |
| 5 | Horn Antenna | Instruments corporation | GTH-0118 | 351600 | Nov. 01, 2019 | 1 Year |
| 6 | Power Sensor | Agilent | E9301A | MY4149890 6 | Nov. 04, 2019 | 1 Year |
| 7 | Power Sensor | Agilent | E9301A | MY4149808 8 | Nov. 04, 2019 | 1 Year |
| 8 | Power Meter | Agilent | E4419B | GB4020290 9 | Nov. 04, 2019 | 1 Year |
| 9 | Field Probe | ETS-Lindgren | HI-6006 | 00212747 | Apr. 20, 2017 | 3 Year |
| 10 | software | EMtrace | EM 3 | N/A | N/A | N/A |

Surge Measurement

| Item | Equipment | Manufacturer | Model No. | Serial No. | Last Cal. | Cal. Interval |
|------|---------------------------------|--------------|-----------|------------|---------------|---------------|
| 1. | Surge Generator | TESEQ | NSG 3060 | 1480 | Nov. 04, 2019 | 1 Year |
| 2. | CDN | TESEQ | CDN 3061 | 1408 | Nov. 04, 2019 | 1 Year |
| 3. | Telecom port surge generator | PMI | TW101 | 190411 | Apr.17,2019 | 1 Year |

Injected Currents Susceptibility Measurement

| Item | Equipment | Manufacturer | Model No. | Serial No. | Last Cal. | Cal. Interval |
|------|------------------------------------------|--------------|-----------------|-------------------|---------------|---------------|
| 1. | C/S Conducted Immunity Test System | FRANKONIA | CIT-10 | 126A1196/20 12 | Nov. 04, 2019 | 1 Year |
| 2. | CDN | FRANKONIA | CDN - M2+ M3 | A2210178/20 12 | Nov. 04, 2019 | 1 Year |
| 3. | 6dB Attenuator | FRANKONIA | DAM 26W | 1172202 | Nov. 04, 2019 | 1 Year |
| 4. | CIT-10 | FRANKONIA | Version1.1.7 | N/A | N.A | N/A |
| 5. | EM-Clamp | FRANKONIA | EMCL-20 | 18101728-01 03 | May.19,2019 | 1 Year |

Voltage Dips and Interruptions Measurement

| Item | Equipment | Manufacturer | Model No. | Serial No. | Last Cal. | Cal. Interval |
|------|------------------------|--------------|----------------|------------|---------------|---------------|
| 1. | CYCLE SAG Simulator | PRIMA | DRP61011A G | PR12046234 | Nov. 04, 2019 | 1 Year |

1.7. Description of Test Facility

The test facility is recognized, certified, or accredited by the following organizations:

FCC-Registration No.: 184111

Shenzhen Anbotek Compliance Laboratory Limited, EMC Laboratory has been registered and fully described in a report filed with the (FCC) Federal Communications Commission. The acceptance letter from the FCC is maintained in our files. Registration No. 184111, September 27, 2019.

ISED-Registration No.: 8058A

Shenzhen Anbotek Compliance Laboratory Limited, EMC Laboratory has been registered and fully described in a report filed with the (ISED) Innovation, Science and Economic Development Canada. The acceptance letter from the ISED is maintained in our files. Registration 8058A, March 07, 2019.

Test Location

Shenzhen Anbotek Compliance Laboratory Limited.

1/F, Building D, Sogood Science and Technology Park, Sanwei community, Hangcheng Street, Bao'an District, Shenzhen, Guangdong, China.518102

1.8. EMS Performance Criteria

- √ A: Normal performance within the specification limits
- √ B: Temporary degradation or loss of function or performance which is self-recoverable
- √ C: Temporary degradation or loss of function or performance which requires operator intervention or system reset
- √ D: Degradation or loss of function which is not recoverable due to damage of equipment (components) or software, or loss of data

Note: The manufacturer's specification may define effects on the EUT which may be considered insignificant, and therefore acceptable.

This classification may be used as a guide in formulating performance criteria, by committees responsible for generic, product and product-family standards, or as a framework for the agreement on performance criteria between the manufacturer and the purchaser, for example where no suitable generic, product or product-family standard exists.



2. Power Line Conducted Emission Test

2.1. Test Standard and Limit

| | |
|---------------|----------|
| Test Standard | EN 55032 |
|---------------|----------|

Limits for conducted emissions

| Test Limit | Frequency (MHz) | At mains terminals (dB μ V) | |
|------------|-----------------|---------------------------------|---------------|
| | | Quasi-peak Level | Average Level |
| | 0.15 ~ 0.50 | 66.0 ~ 56.0 * | 56.0 ~ 46.0 * |
| | 0.50 ~ 5.00 | 56.0 | 46.0 |
| | 5.00 ~ 30.00 | 60.0 | 50.0 |

Remark: (1) The lower limit shall apply at the transition frequencies.

(2) The limit decreases linearly with the logarithm of the frequency in the range 0.15MHz to 0.50MHz.

2.2. Test Setup

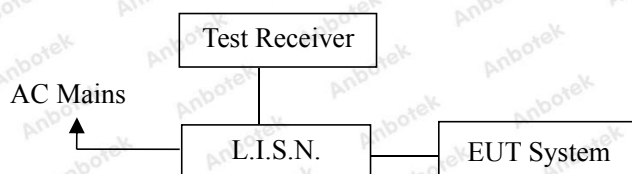

2.3. EUT Configuration on Measurement

The following equipments are installed on conducted emission measurement to meet EN 55032 requirements and operating in a manner which tends to maximize its emission characteristics in a normal application.

2.4. Operating Condition of EUT

2.4.1. Setup the EUT as shown in Section 2.2.

2.4.2. Turn on the power of all equipments.

2.4.3. Let the EUT work in test mode and measure it.

2.5. Test Procedure

The EUT is put on the plane 0.8 m high above the ground by insulating support and connected to the AC mains through Line Impedance Stability Network(L.I.S.N). This provided a 50ohm coupling impedance for the tested equipments. Both sides of AC line are investigated to find out the maximum conducted emission according to the EN55032 regulations during conducted emission measurement.

The bandwidth of the field strength meter (R&S Test Receiver ESCI) is set at 9kHz in 150kHz~30MHz.

The frequency range from 150kHz to 30MHz is investigated for AC mains.

All the test results are listed in Section 2.6.

2.6. Test Results

PASS

The test curves are shown in the following pages.

Conducted Emission Test Data

Test Site: 1# Shielded Room
 Test Specification: DC 5V via adapter
 Comment: Live Line
 Temp.: 22.5°C Hum.: 52%

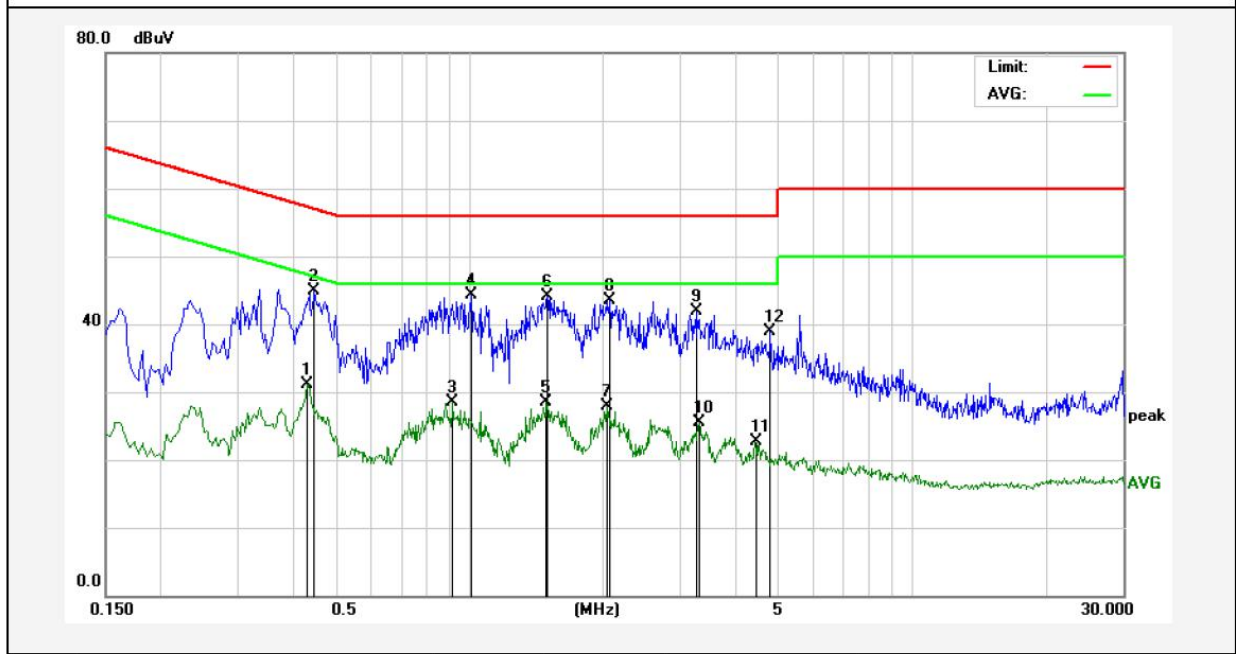

| No. | Freq. (MHz) | Reading (dBuV) | Factor (dB) | Result (dBuV) | Limit (dBuV) | Over Limit (dB) | Detector | Remark |
|-----|-------------|----------------|-------------|---------------|--------------|-----------------|----------|--------|
| 1 | 0.4300 | 11.17 | 19.95 | 31.12 | 47.25 | -16.13 | AVG | |
| 2 | 0.4460 | 25.01 | 19.96 | 44.97 | 56.95 | -11.98 | QP | |
| 3 | 0.9140 | 8.31 | 20.10 | 28.41 | 46.00 | -17.59 | AVG | |
| 4 | 1.0100 | 24.19 | 20.12 | 44.31 | 56.00 | -11.69 | QP | |
| 5 | 1.4900 | 8.35 | 20.13 | 28.48 | 46.00 | -17.52 | AVG | |
| 6 | 1.4980 | 24.00 | 20.13 | 44.13 | 56.00 | -11.87 | QP | |
| 7 | 2.0420 | 7.73 | 20.14 | 27.87 | 46.00 | -18.13 | AVG | |
| 8 | 2.0740 | 23.42 | 20.14 | 43.56 | 56.00 | -12.44 | QP | |
| 9 | 3.2620 | 21.68 | 20.17 | 41.85 | 56.00 | -14.15 | QP | |
| 10 | 3.2980 | 5.35 | 20.17 | 25.52 | 46.00 | -20.48 | AVG | |
| 11 | 4.4300 | 2.45 | 20.19 | 22.64 | 46.00 | -23.36 | AVG | |
| 12 | 4.7860 | 18.65 | 20.20 | 38.85 | 56.00 | -17.15 | QP | |

Note: Result=Reading+Factor Over Limit=Result-Limit

Conducted Emission Test Data

Test Site: 1# Shielded Room
 Test Specification: DC 5V via adapter
 Comment: Neutral Line
 Temp.: 22.5°C Hum.: 52%

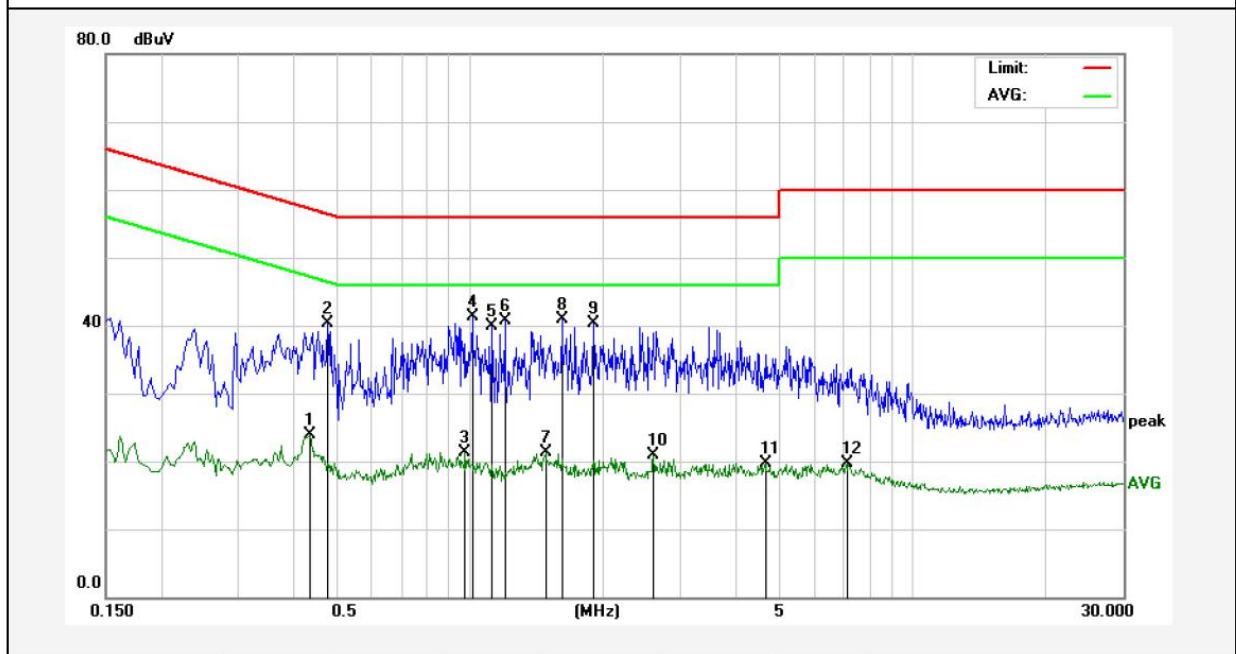

| No. | Freq. (MHz) | Reading (dBuV) | Factor (dB) | Result (dBuV) | Limit (dBuV) | Over Limit (dB) | Detector | Remark |
|-----|-------------|----------------|-------------|---------------|--------------|-----------------|----------|--------|
| 1 | 0.4340 | 4.01 | 19.95 | 23.96 | 47.18 | -23.22 | AVG | |
| 2 | 0.4780 | 20.31 | 19.97 | 40.28 | 56.37 | -16.09 | QP | |
| 3 | 0.9780 | 1.28 | 20.11 | 21.39 | 46.00 | -24.61 | AVG | |
| 4 | 1.0140 | 21.10 | 20.12 | 41.22 | 56.00 | -14.78 | QP | |
| 5 | 1.1220 | 19.71 | 20.12 | 39.83 | 56.00 | -16.17 | QP | |
| 6 | 1.1980 | 20.57 | 20.12 | 40.69 | 56.00 | -15.31 | QP | |
| 7 | 1.4860 | 1.19 | 20.13 | 21.32 | 46.00 | -24.68 | AVG | |
| 8 | 1.6140 | 20.74 | 20.13 | 40.87 | 56.00 | -15.13 | QP | |
| 9 | 1.9020 | 20.14 | 20.14 | 40.28 | 56.00 | -15.72 | QP | |
| 10 | 2.6020 | 0.85 | 20.15 | 21.00 | 46.00 | -25.00 | AVG | |
| 11 | 4.6620 | -0.50 | 20.20 | 19.70 | 46.00 | -26.30 | AVG | |
| 12 | 7.1260 | -0.63 | 20.26 | 19.63 | 50.00 | -30.37 | AVG | |

Note: Result=Reading+Factor Over Limit=Result-Limit

3. Radiated Emission Test

3.1. Test Standard and Limit

| | |
|---------------|----------|
| Test Standard | EN 55032 |
|---------------|----------|

Radiated Emission Test Limit

| Test Limit | Frequency (MHz) | DISTANCE (Meters) | FIELD STRENGTHS LIMIT (dB μ V/m) |
|------------|-----------------|-------------------|--------------------------------------|
| | 30 ~ 230 | 3 | 40 |
| | 230 ~ 1000 | 3 | 47 |

Remark: (1)The smaller limit shall apply at the combination point between two frequency bands.
 (2) Distancer efers to the distance in meters between the measuring instrument antenna and the closed point of any part of the EUT.
 (3) 3M Limit=10M Limit+k $k=20\log(D1/D2)=10$
 3M Limit=10M Limit +10
 (D1= 10M D2=3M)

3.2. Test Setup

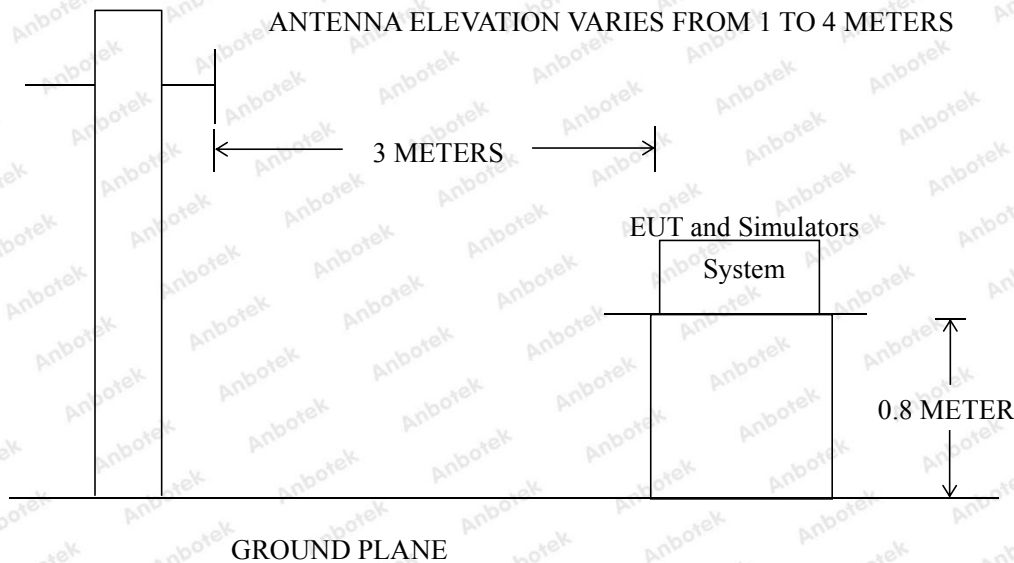

3.3. EUT Configuration on Measurement

The EN 55032 regulations test method must be used to find the maximum emission during radiated emission measurement.

3.4. Operating Condition of EUT

3.4.1. Setup the EUT as shown in Section 3.2.

3.4.2. Turn on the power of all equipments.

3.4.3. Let the EUT work in test mode and measure it.

3.5. Test Procedure

The EUT is placed on a turn table which is 0.8 meter high above the ground. The turn table can rotate 360 degrees to determine the position of the maximum emission level. The EUT is set 3 meters away from the receiving antenna which is mounted on a antenna tower. The antenna can be moved up and down from 1 to 4 meters to find out the maximum emission level. Bilog antenna is used as a receiving antenna. Both horizontal and vertical polarization of the antenna are set on test.

The bandwidth of the Receiver (ESCI) is set at 120kHz.

The EUT is tested in 9*6*6 Chamber.

The test results are listed in Section 3.6.

3.6. Test Results

PASS

The frequency range from 30MHz to 1000MHz is investigated.

The test curves are shown in the following pages.

Test item: Radiation Test **Polarization:** Horizontal
Standard: (RE)EN55032 **Power Source:** DC 5V via adapter
Distance: 3m **Temp.(°C)/Hum.(%RH):** 22.6(°C)/57%RH

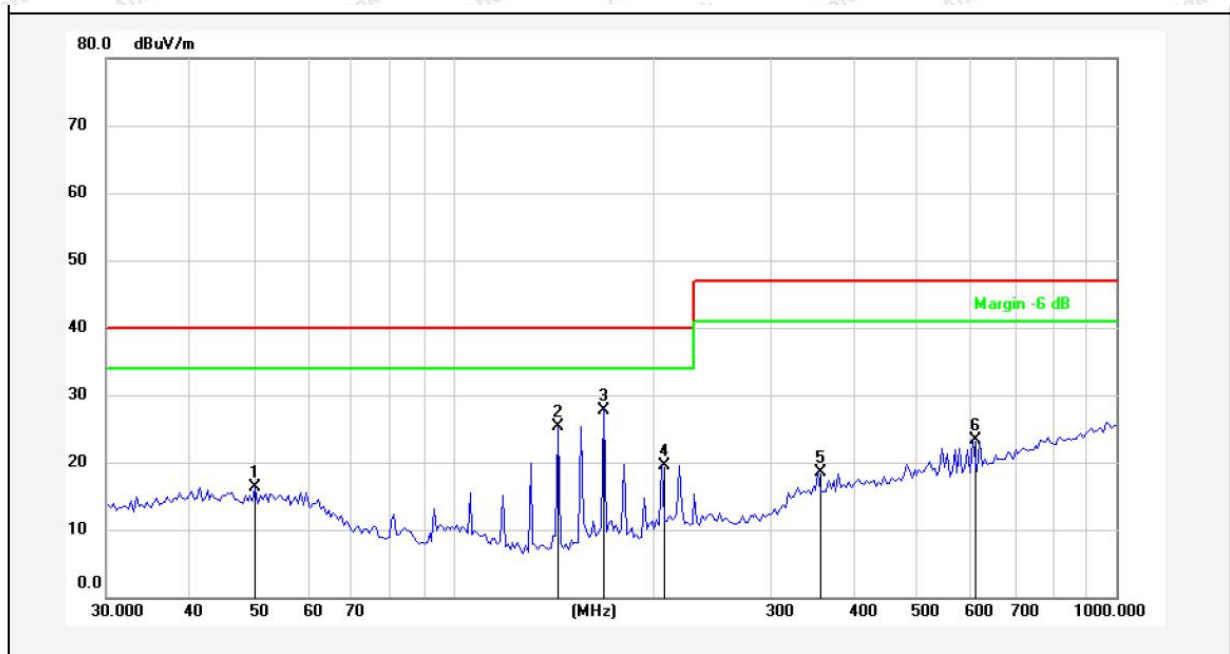

| No. | Freq. (MHz) | Reading (dBuV) | Factor () | Result (dBuV/m) | Limit (dBuV/m) | Over Limit (dB) | Detector | Height (cm) | degree (deg) | Remark |
|-----|-------------|----------------|------------|-----------------|----------------|-----------------|----------|-------------|--------------|--------|
| 1 | 50.3206 | 33.20 | -16.93 | 16.27 | 40.00 | -23.73 | peak | | | |
| 2 | 144.0819 | 49.73 | -24.42 | 25.31 | 40.00 | -14.69 | peak | | | |
| 3 | 168.7093 | 50.53 | -22.73 | 27.80 | 40.00 | -12.20 | peak | | | |
| 4 | 206.3976 | 41.48 | -21.91 | 19.57 | 40.00 | -20.43 | peak | | | |
| 5 | 355.4273 | 35.17 | -16.59 | 18.58 | 47.00 | -28.42 | peak | | | |
| 6 | 606.7221 | 37.15 | -13.93 | 23.22 | 47.00 | -23.78 | peak | | | |

Note: Result=Reading+Factor Over Limit=Result-Limit

Test item: Radiation Test **Polarization:** Vertical
Standard: (RE)EN55032 **Power Source:** DC 5V via adapter
Distance: 3m **Temp.(°C)/Hum.(%RH):** 22.6(°C)/57%RH

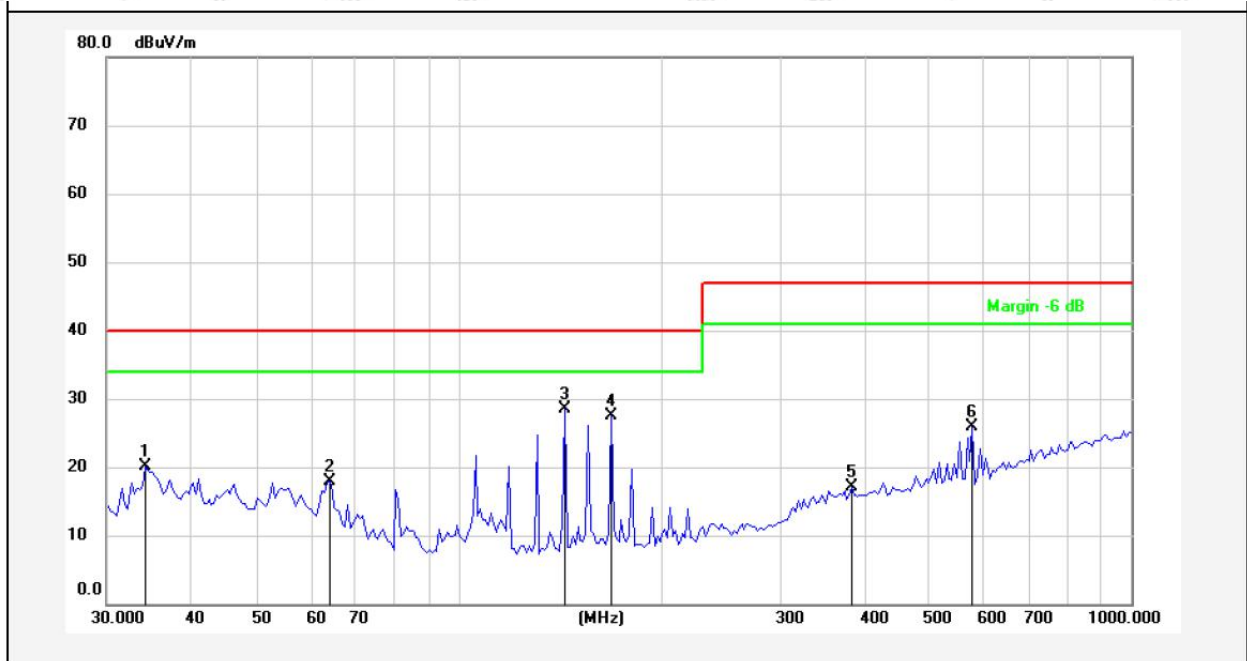

| No. | Freq. (MHz) | Reading (dBuV) | Factor () | Result (dBuV/m) | Limit (dBuV/m) | Over Limit (dB) | Detector | Height (cm) | degree (deg) | Remark |
|-----|-------------|----------------|------------|-----------------|----------------|-----------------|----------|-------------|--------------|--------|
| 1 | 34.2160 | 37.00 | -16.84 | 20.16 | 40.00 | -19.84 | peak | | | |
| 2 | 64.3202 | 35.98 | -18.10 | 17.88 | 40.00 | -22.12 | peak | | | |
| 3 | 144.0819 | 48.97 | -20.42 | 28.55 | 40.00 | -11.45 | peak | | | |
| 4 | 168.7093 | 47.12 | -19.60 | 27.52 | 40.00 | -12.48 | peak | | | |
| 5 | 384.6055 | 32.25 | -15.16 | 17.09 | 47.00 | -29.91 | peak | | | |
| 6 | 580.7026 | 38.45 | -12.53 | 25.92 | 47.00 | -21.08 | peak | | | |

Note: Result=Reading+Factor Over Limit=Result-Limit

4. Harmonic Current Emission Test

4.1. Test Standard

| | |
|---------------|--------------|
| Test Standard | EN 61000-3-2 |
|---------------|--------------|

4.2. Test Setup

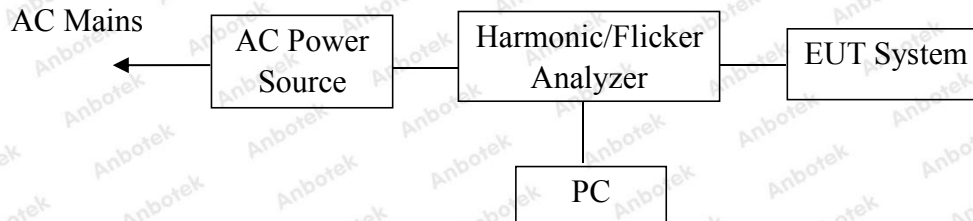

4.3. Operating Condition of EUT

- 4.3.1. Setup the EUT as shown on Section 4.2.
- 4.3.2. Turn on the power of all equipments.
- 4.3.3. After that, let the EUT work in test mode measure it.

4.4. Test Results

The active input power of the EUT is less than 75W. Therefore, according to EN 61000-3-2, no limits are necessary.

5. Voltage Fluctuations & Flicker Test

5.1. Test Standard

| | |
|---------------|--------------|
| Test Standard | EN 61000-3-3 |
|---------------|--------------|

5.2. Test Setup

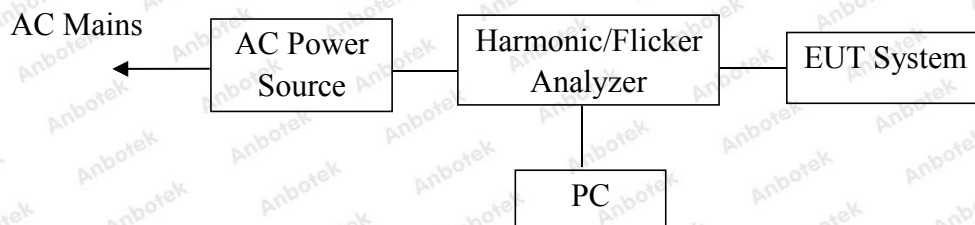

5.3. Operating Condition of EUT

- 5.3.1. Setup the EUT as shown on Section 5.2.
- 5.3.2. Turn on the power of all equipments.
- 5.3.3. After that, let the EUT work in test mode measure it.

5.4. Test Results

PASS

The test curves are shown in the following pages.

Flicker Test Summary per EN/IEC61000-3-3 (Run time)

Flicker Emission IEC 61000-4-15 for 230V/50Hz

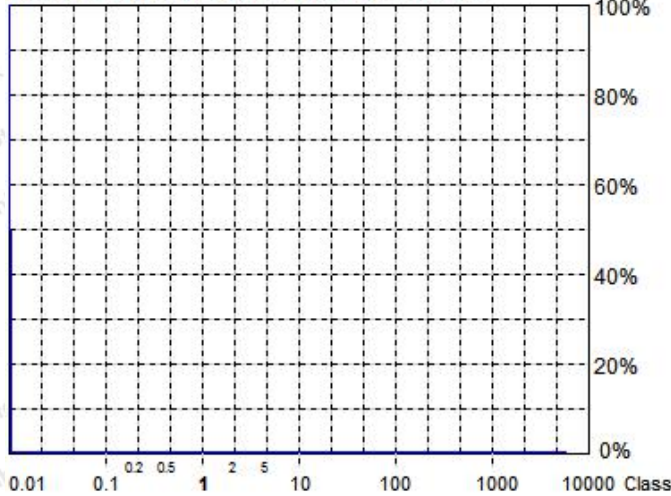

| | |
|---------------------------------------------------|---------------|
| Actual Flicker (Fli): | 0.00 |
| Short-term Flicker (Pst): | 0.07 |
| Limit (Pst): | 1.00 |
| Long-term Flicker (Plt): | 0.07 |
| Limit (Plt): | 0.65 |
| Maximum Relative Volt. Change (dmax): | 0.00% |
| Limit (dmax): | 4.00% |
| Relative Steady-state Voltage Change (dc): | 0.02% |
| Limit (dc): | 3.00% |
| Tmax 3.30% (dt): | 0.00ms |
| Limit (dt>Lim): | 500ms |

Flicker Emission - IEC 61000-3-3, EN 61000-3-3

| | | | |
|--------|---------|------|---------|
| Urms = | 229.5 V | P = | 2.442 W |
| Irms = | 0.029 A | pf = | 0.369 |

| | |
|--------|-------|
| Range: | 0.5 A |
| V-nom: | 230 V |

Test completed, Result: PASSED

HAR-1000 EMC-Partner

Full Bar : Actual Values

Empty Bar : Maximum Values

Circles : Average Values

Blue : Current , Green : Voltage , Red : Failed

| | | | | | |
|--------|--------|--------|---------|--------|-------|
| Urms = | 229.5V | Freq = | 49.987 | Range: | 0.5 A |
| Irms = | 0.029A | Ipk = | 0.194A | cf = | 6.737 |
| P = | 2.442W | S = | 6.612VA | pf = | 0.369 |

Test - Time : 1 x 10min = 10min (100 %)

LIN (Line Impedance Network) : L: 0.24ohm +j0.15ohm N: 0.16ohm +j0.10ohm

| | | | | |
|-----------------|---------------|---------------|-------------------|---------------|
| Limits : | Plt : | 0.65 | Pst : | 1.00 |
| | dmax : | 4.00 % | dc : | 3.00 % |
| | dtLim: | 3.30 % | dt>Lim: | 500ms |

Test completed, Result: PASSED

| | | | |
|----------|--------------|--------------|------------------|
| | dmax | dc | dt>Lim |
| | [%] | [%] | [ms] |
| 1 | 0.000 | 0.020 | 0.000 |

Shenzhen Anbotek Compliance Laboratory Limited

Code:AB-EMC-02-b

Address: 1/F., Building D, Sogood Science and Technology Park, Sanwei Community, Hangcheng Street, Bao'an District, Shenzhen, Guangdong, China.

Tel:(86) 755-26066440 Fax: (86) 755-26014772 Email: service@anbotek.com

Hotline
400-003-0500
www.anbotek.com

6. Electrostatic Discharge Immunity Test

6.1. Test Standard and Level

| | |
|-----------------------------------------------------------------------------------------|--------------------------|
| Test Standard: | EN 55035 (IEC 61000-4-2) |
| Performance Criterion: | B |
| Severity Level: 3 / Air Discharge: ± 8 kV, Level: 2 / Contact Discharge: ± 4 kV | |

Test Level

| Level | Test Voltage Contact Discharge (kV) | Test Voltage Air Discharge (kV) |
|-------|----------------------------------------|------------------------------------|
| 1. | ± 2 | ± 2 |
| 2. | ± 4 | ± 4 |
| 3. | ± 6 | ± 8 |
| 4. | ± 8 | ± 15 |
| X. | Special | Special |

6.2. Test Setup

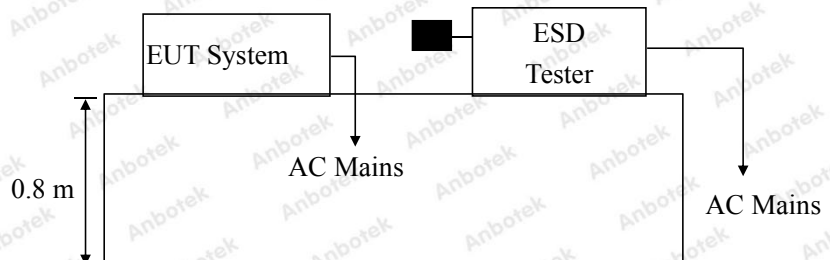

6.3. EUT Configuration on Measurement

The following equipments are installed on electrostatic discharge immunity measurement to meet EN 55035 requirements and operating in a manner which tends to maximize its emission characteristics in a normal application.

6.4. Operating Condition of EUT

- 6.4.1. Setup the EUT as shown on Section 6.2.
- 6.4.2. Turn on the power of all equipments.
- 6.4.3. After that, let the EUT work in test mode measure it.

6.5. Test Procedure

6.5.1. Air Discharge:

This test is done on a non-conductive surface. The round discharge tip of the discharge electrode shall be approached as fast as possible to touch the EUT. After each discharge, the discharge electrode shall be removed from the EUT. The generator is then re-triggered for a new single discharge and repeated 10 times for each pre-selected test point. This procedure shall be repeated until all the air discharge completed

6.5.2. Contact Discharge:

All the procedure shall be same as Section 6.5.1. except that the tip of the discharge electrode shall touch the EUT before the discharge switch is operated.

6.5.3. Indirect discharge for horizontal coupling plane

At least 20 single discharges shall be applied to the horizontal coupling plane, at points on each side of the EUT. The discharge electrode positions vertically at a distance of 0.1m from the EUT and with the discharge electrode touching the coupling plane.

6.5.4. Indirect discharge for vertical coupling plane

At least 20 single discharge shall be applied to the center of one vertical edge of the coupling plane. The coupling plane, of dimensions 0.5m × 0.5m, is placed parallel to, and positioned at a distance of 0.1m from the EUT. Discharges shall be applied to the coupling plane, with this plane in sufficient different positions that the four faces of the EUT are completely illuminated.

6.6. Test Results

PASS

Please refer to the following page.



Electrostatic Discharge Test Results

| | | | |
|-----------------------|-------------------|--------------------|------------------------------------------------------------------------|
| Air discharge : | ±8.0kV | Temperature : | 24.6°C |
| Contact discharge : | ±4.0kV | Humidity : | 51% |
| Power Supply : | DC 5V via adapter | Expert conclusion: | A |
| Number of discharge : | 10 | Test Result: | <input checked="" type="checkbox"/> Pass <input type="checkbox"/> Fail |

| Location | | Kind A-Air Discharge C-Contact Discharge | Result |
|------------------|----------|------------------------------------------------|---------------------------------------------------------------------------------------------------------------------------|
| Metal | 4 points | C | <input checked="" type="checkbox"/> A <input type="checkbox"/> B <input type="checkbox"/> C <input type="checkbox"/> D |
| Light | 4 points | A | <input checked="" type="checkbox"/> A <input type="checkbox"/> B <input type="checkbox"/> C <input type="checkbox"/> D |
| Type-C Port | 4 points | C | <input checked="" type="checkbox"/> A <input type="checkbox"/> B <input type="checkbox"/> C <input type="checkbox"/> D |
| DC Port | 4 points | A | <input checked="" type="checkbox"/> A <input type="checkbox"/> B <input type="checkbox"/> C <input type="checkbox"/> D |
| HCP | 4 points | C | <input checked="" type="checkbox"/> A <input type="checkbox"/> B <input type="checkbox"/> C <input type="checkbox"/> D |
| VCP of the front | 4 points | C | <input checked="" type="checkbox"/> A <input type="checkbox"/> B <input type="checkbox"/> C <input type="checkbox"/> D |
| VCP of the rear | 4 points | C | <input checked="" type="checkbox"/> A <input type="checkbox"/> B <input type="checkbox"/> C <input type="checkbox"/> D |
| VCP of the left | 4 points | C | <input checked="" type="checkbox"/> A <input type="checkbox"/> B <input type="checkbox"/> C <input type="checkbox"/> D |
| VCP of the right | 4 points | C | <input checked="" type="checkbox"/> A <input type="checkbox"/> B <input type="checkbox"/> C <input type="checkbox"/> D |
| | | | |
| | | | |

Remark: Discharge should be considered on Contact and Air and Horizontal Coupling Plane (HCP) and Vertical Coupling Plane (VCP).

7. RF Field Strength Susceptibility Test

7.1. Test Standard and Level

| | |
|-----------------------|------------------------------------------------------|
| Test Standard: | EN 55035 (IEC 61000-4-3) |
| Required Performance: | A |
| Frequency Range: | 80MHz to 1000MHz, 1800MHz, 2600MHz, 3500MHz, 5000MHz |
| Field Strength: | 3 V/m |
| Modulation: | 1kHz Sine Wave, 80%, AM Modulation |
| Frequency Step: | 1 % of preceding frequency value |
| Polarity of Antenna: | Horizontal and Vertical |
| Test Distance: | 3 m |
| Antenna Height: | 1.5 m |
| Dwell Time: | at least 0.5s |

Test Level

| Level | Field Strength V/m |
|-------|-----------------------|
| 1. | 1 |
| 2. | 3 |
| 3. | 10 |
| X. | Special |

7.2. Test Setup

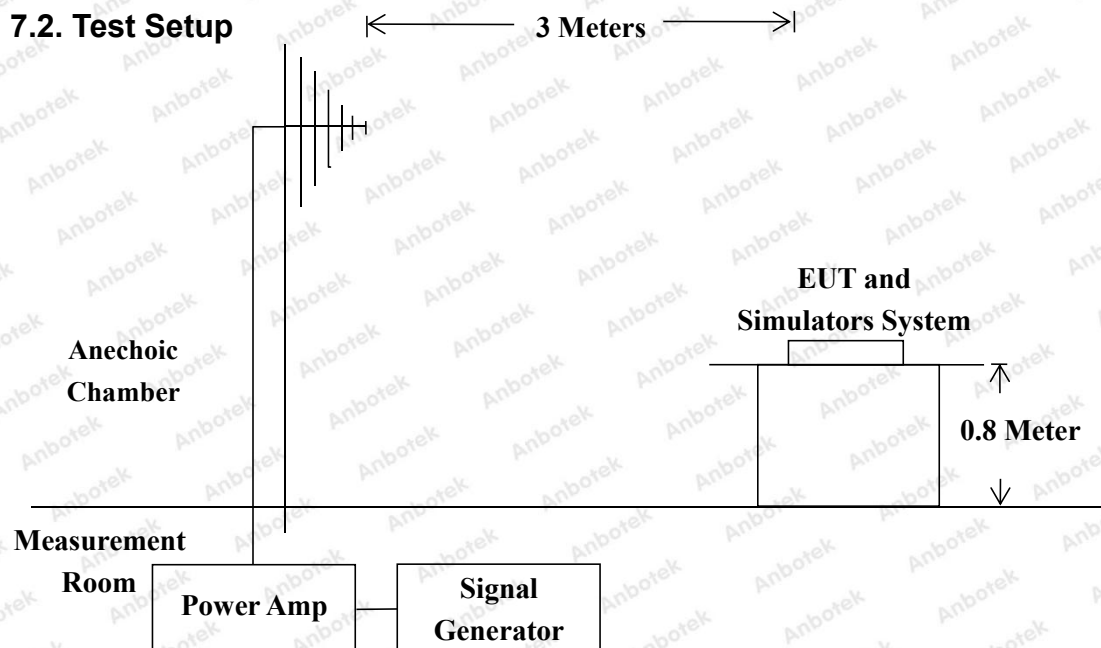

7.3. EUT Configuration on Measurement

The following equipments are installed on RF Field Strength susceptibility Measurement to meet EN 55035 requirements and operating in a manner which tends to maximize its emission characteristics in a normal application.

7.4. Operating Condition of EUT

7.4.1. Setup the EUT as shown on Section 7.2.

7.4.2. Turn on the power of all equipments.

7.4.3. After that, let the EUT work in test mode measure it.

7.5. Test Procedure

The EUT and support equipment, which are placed on a table that is 0.8 meter above ground and the testing was performed in a fully-anechoic chamber. The testing distance from antenna to the EUT was 3 meters.

- 1) 80 MHz to 1000 MHz the field strength level was 3V/m, 1800MHz, 2600MHz, 3500MHz, 5000MHz the field strength level was 3V/m.
- 2) The frequency range is swept from 80 MHz to 1000 MHz with the signal 80% amplitude modulated with a 1kHz sine wave.
- 3) The frequency range is swept from 1800MHz, 2600MHz, 3500MHz, 5000MHz with the signal 80% amplitude modulated with a 1kHz sine wave.
- 4) The dwell time at each frequency shall be not less than the time necessary for the EUT to be able to respond, but shall in no case be less than 0.5s.
- 5) The test was performed with the EUT exposed to both vertically and horizontally polarized fields on each of the four sides.

7.6. Measuring Results

PASS

Please refer to the following page.



RF Field Strength Susceptibility Test Results

| | | | |
|--------------------|-------------------|---------------|------------------------------------------------------------------------|
| Field Strength : | 3V/m | Temperature : | 23.5°C |
| Expert conclusion: | A | Humidity : | 53% |
| Power Supply : | DC 5V via adapter | Test Result : | <input checked="" type="checkbox"/> Pass <input type="checkbox"/> Fail |
| Dwell Time: | 1s | | |

| Frequency Range | Antenna Polarity | R.F. Field Strength | Azimuth | Result |
|------------------------------------------|------------------|---------------------|---------|---------------------------------------------------------------------------------------------------------------------------|
| 80MHz~1000MHz | H / V | 3 V/m (rms) | Front | <input checked="" type="checkbox"/> A <input type="checkbox"/> B <input type="checkbox"/> C <input type="checkbox"/> D |
| | | | Rear | |
| | | | Left | |
| | | | Right | |
| 1800MHz 2600MHz 3500MHz 5000MHz | H / V | 3 V/m (rms) | Front | <input checked="" type="checkbox"/> A <input type="checkbox"/> B <input type="checkbox"/> C <input type="checkbox"/> D |
| | | | Rear | |
| | | | Left | |
| | | | Right | |

8. Electrical Fast Transient/Burst Immunity Test

8.1. Test Standard and Level

| | |
|--------------------------|--------------------------|
| Test Standard: | EN 55035 (IEC 61000-4-4) |
| Performance criterion: | B |
| Severity Level 2: 1.00kV | |

Test Level

| Open Circuit Output Test Voltage $\pm 10\%$ | | |
|---------------------------------------------|-----------------------|-----------------------------------------------------|
| Level | On Power Supply Lines | On I/O (Input/Output) Signal data and control lines |
| 1. | 0.50 kV | 0.25 kV |
| 2. | 1.00 kV | 0.50 kV |
| 3. | 2.00 kV | 1.00 kV |
| 4. | 4.00 kV | 2.00 kV |
| X. | Special | Special |

8.2. Test Setup

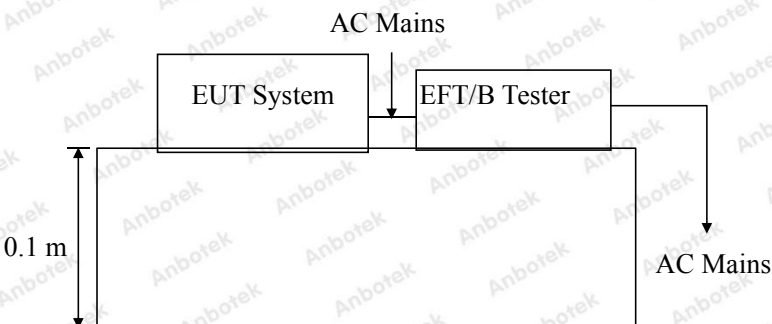

8.3. EUT Configuration on Measurement

The following equipments are installed on electrical fast transient/burst immunity measurement to meet EN 55035 requirements and operating in a manner which tends to maximize its emission characteristics in a normal application.

8.4. Operating Condition of EUT

8.4.1. Setup the EUT as shown in Section 8.2.

8.4.2. Turn on the power of all equipments.

8.4.3. Let the EUT work in test mode and measure it.

8.5. Test Procedure

The EUT is put on the table which is 0.1 meter high above the ground. This reference ground plane shall project beyond the EUT by at least 0.1m on all sides and the minimum distance between EUT and all other conductive structure, except the ground plane beneath the EUT, shall be more than 0.5m.

8.5.1. For input and output AC power ports:

The EUT is connected to the Power mains by using a coupling device which couples the EFT interference signal to AC Power lines. Both polarities of the test voltage should be applied during compliance test and the duration of the test is 2 mins.

8.5.2. For signal lines and control lines ports:

Select tests based on product characteristics.

8.5.3. For DC output line ports:

Select tests based on product characteristics.

8.6. Test Results

PASS

Please refer to the following page.

Electrical Fast Transient/Burst Test Results

| Ambient Condition : 24.6°C / 51% RH | | Expert conclusion: A | |
|-------------------------------------|----------|--------------------------------------------------------------------------------------|---------------------------------------------------------------------------------------------------------------------------|
| Power Supply .: DC 5V via adapter | | Test Result : <input checked="" type="checkbox"/> Pass <input type="checkbox"/> Fail | |
| Inject Line : AC Mains | | Inject Method: Direct | Inject Time(s): 120 |
| Line | Polarity | Test Voltage (kV) | Result |
| AC Line | ± | 1.00kV | <input checked="" type="checkbox"/> A <input type="checkbox"/> B <input type="checkbox"/> C <input type="checkbox"/> D |
| DC Line | | | |
| Signal Line | | | |
| | | | |

9. Surge Immunity Test

9.1. Test Standard and Level

| | |
|---------------------------------------|--------------------------|
| Test Standard: | EN 55035 (IEC 61000-4-5) |
| Performance criterion: | B |
| Severity Level 2, Line to Line: 1.0kV | |

Test Level

| Severity Level | Open-Circuit Test Voltage (kV) |
|----------------|--------------------------------|
| 1. | 0.5 |
| 2. | 1.0 |
| 3. | 2.0 |
| 4. | 4.0 |
| X. | Special |

9.2. Test Setup

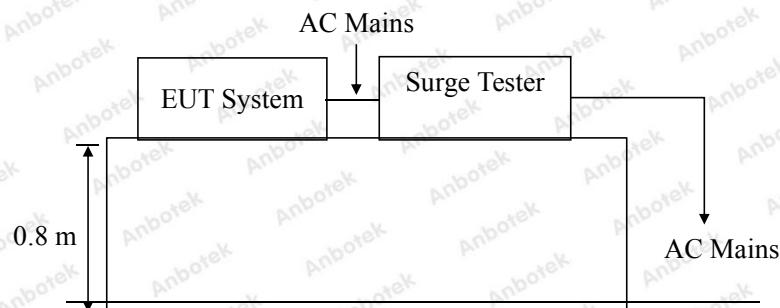

9.3. EUT Configuration on Measurement

The following equipments are installed on surge immunity measurement to meet EN 55035 requirements and operating in a manner which tends to maximize its emission characteristics in a normal application.

9.4. Operating Condition of EUT

- 9.4.1. Setup the EUT as shown in Section 9.2.
- 9.4.2. Turn on the power of all equipments.
- 9.4.3. Let the EUT work in test mode and measure it.

9.5. Test Procedure

9.5.1. Set up the EUT and test generator as shown on Section 9.2.

9.5.2. For line to line coupling mode, provide a 1.0 kV 1.2/50us voltage surge (at open-circuit condition) and 8/20us current surge to EUT selected points.

9.5.3. At least 5 positive and 5 negative (polarity) tests with a maximum 1/min repetition rate are conducted during test.

9.5.4. Different phase angles are done individually.

9.5.5. Record the EUT operating situation during compliance test and decide the EUT immunity criterion for above each test.

9.6. Test Results

PASS

Please refer to the following page.



Surge Immunity Test Results

| | | | | | |
|----------------|------------------------------------------------------------------------|------------------------------------------------------------------------------------------------------------------------------------|-----------------|--------------------|---------------------------------------------------------------------------------------------------------------------------|
| Humidity : | 51% | Temperature : | 24.6℃ | | |
| Power Supply : | DC 5V via adapter | Expert conclusion: | A | | |
| Test Result : | <input checked="" type="checkbox"/> Pass <input type="checkbox"/> Fail | | | | |
| | | | | | |
| Location | Polarity | Phase Angle | Number of Pulse | Pulse Voltage (kV) | Result |
| L-N | + | <input type="checkbox"/> 0° <input checked="" type="checkbox"/> 90° <input type="checkbox"/> 180° <input type="checkbox"/> 270° | 5 | 1.0kV | <input checked="" type="checkbox"/> A <input type="checkbox"/> B <input type="checkbox"/> C <input type="checkbox"/> D |
| L-N | - | <input type="checkbox"/> 0° <input type="checkbox"/> 90° <input type="checkbox"/> 180° <input checked="" type="checkbox"/> 270° | 5 | 1.0kV | <input checked="" type="checkbox"/> A <input type="checkbox"/> B <input type="checkbox"/> C <input type="checkbox"/> D |
| L-PE | | | | | |
| L-PE | | | | | |
| N-PE | | | | | |
| N-PE | | | | | |
| | | | | | |

10. Injected Currents Susceptibility Test

10.1. Test Standard and Level

| | |
|-----------------------|--------------------------|
| Test Standard | EN 55035 (IEC 61000-4-6) |
| Performance criterion | A |

Test Level

| Level | Field Strength V |
|-------|------------------|
| 1. | 1 |
| 2. | 3 |
| 3. | 10 |
| X. | Special |

10.2. Test Setup

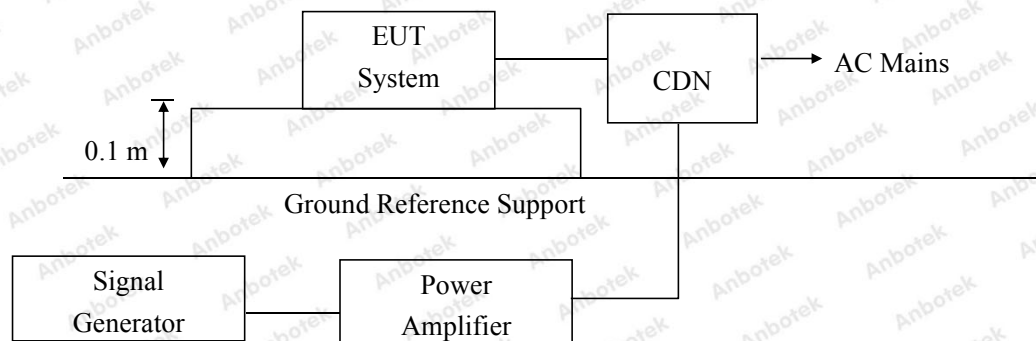

10.3. EUT Configuration

The following equipments are installed on currents susceptibility measurement to meet EN 55035 requirements and operating in a manner which tends to maximize its emission characteristics in a normal application.

10.4. Operating Condition of EUT

- 10.4.1. Setup the EUT as shown in Section 10.2.
- 10.4.2. Turn on the power of all equipments.
- 10.4.3. Let the EUT work in test mode and measure it.

10.5. Test Procedure

- 1) Set up the EUT, CDN and test generators as shown on Section 10.2.
- 2) Let the EUT work in test mode and measure it.
- 3) The EUT are placed on an insulating support 0.1m high above a ground reference plane. CDN (coupling and decoupling device) is placed on the ground plane about 0.3m from EUT. Cables between CDN and EUT are as short as possible, and their height above the ground reference plane shall be between 30 and 50 mm (where possible).
- 4) The disturbance signal described below is injected to EUT through CDN.
- 5) The EUT operates within its operational mode(s) under intended climatic conditions after power on.
- 6) The frequency range is swept from 150KHz to 10MHz using 3V signal level, 10MHz to 30MHz using 3V to 1V signal level, 30MHz to 80MHz using 1V signal level, and with the disturbance signal 80% amplitude modulated with a 1KHz sine wave.
- 7) The rate of sweep shall not exceed 1.5×10^{-3} decades/s. Where the frequency is swept incrementally, the step size shall not exceed 1% of the start and thereafter 1% of the preceding frequency value.
- 8) Recording the EUT operating situation during compliance testing and decide the EUT immunity criterion.

10.5.1. For signal lines and control lines ports:

Select tests based on product characteristics.

10.5.2. For DC output line ports:

Select tests based on product characteristics.

10.6. Test Results

PASS

Please refer to the following page.



Injected Currents Susceptibility Test Results

| | | | |
|--------------------------------------------------------------------------------------|----------|----------------------|---------------------------------------------------------------------------------------------------------------------------|
| Humidity : 53% | | Temperature : 23.5°C | |
| Power Supply : DC 5V via adapter | | Expert conclusion: A | |
| Test Result : <input checked="" type="checkbox"/> Pass <input type="checkbox"/> Fail | | | |
| Frequency Range (MHz) | | Injected Position | Strength (Unmodulated) |
| 0.15 ~ 10 | AC Mains | 3V | <input checked="" type="checkbox"/> A <input type="checkbox"/> B <input type="checkbox"/> C <input type="checkbox"/> D |
| 10 ~ 30 | AC Mains | 3V to 1V | <input checked="" type="checkbox"/> A <input type="checkbox"/> B <input type="checkbox"/> C <input type="checkbox"/> D |
| 30 ~ 80 | AC Mains | 1V | <input checked="" type="checkbox"/> A <input type="checkbox"/> B <input type="checkbox"/> C <input type="checkbox"/> D |
| <p>Remark : 1. Modulation Signal:1KHz 80% AM</p> | | | |

11. Voltage Dips And Interruptions Test

11.1. Test Standard and Level

| | |
|------------------------|---------------------------|
| Test Standard: | EN 55035 (IEC 61000-4-11) |
| Performance Criterion: | B&C |

Test Level

| Test Level %UT | Voltage dip and short interruptions %UT | Duration (in period) |
|-------------------|--------------------------------------------|-------------------------|
| 0 | 100 | 0.5 |
| 40 | 60 | 1 |
| 70 | 30 | 5 |
| 0 | 100 | 10 |
| | | 25 |
| | | 50 |
| | | * |

11.2. Test Setup

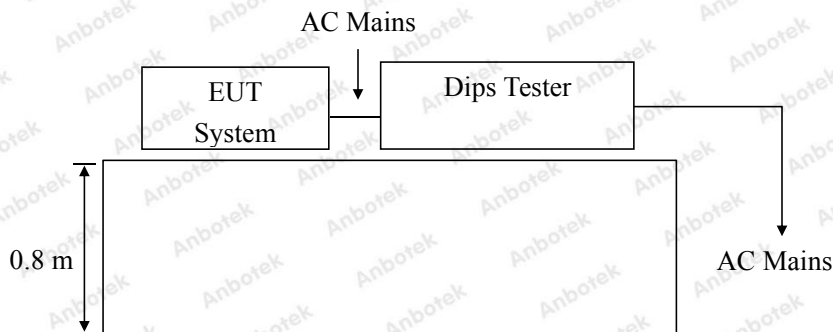

11.3. EUT Configuration on Measurement

The following equipments are installed on voltage dips and interruptions measurement to meet EN 55035 requirements and operating in a manner which tends to maximize its emission characteristics in a normal application.

11.4. Operating Condition of EUT

11.4.1. Setup the EUT as shown in Section 11.2.

11.4.2. Turn on the power of all equipments.

11.4.3. Let the EUT work in test mode and measure it.

11.5. Test Procedure

- 1) Set up the EUT and test generator as shown on Section 11.2.
- 2) The interruptions is introduced at selected phase angles with specified duration.
- 3) Record any degradation of performance.

11.6. Test Results

PASS

Please refer to the following page.



Voltage Dips and Interruptions Test Results

| Temperature : 24.6°C | | Humidity : 51% | |
|--------------------------------------------------------------------------------------|-----------------------------------------------|------------------------|---------------------------------------------------------------------------------------------------------------------------|
| Power Supply : DC 5V via adapter | | Expert conclusion: B&C | |
| Test Result : <input checked="" type="checkbox"/> Pass <input type="checkbox"/> Fail | | | |
| | | | |
| Test Level % UT | Voltage Dips & Short Interruptions % UT | Duration (in periods) | Result |
| 0 | 100 | 0.5P | <input type="checkbox"/> A <input checked="" type="checkbox"/> B <input type="checkbox"/> C <input type="checkbox"/> D |
| 70 | 30 | 25P | <input type="checkbox"/> A <input type="checkbox"/> B <input checked="" type="checkbox"/> C <input type="checkbox"/> D |
| | | | |
| | | | |
| Test Level % UT | Voltage Dips & Short Interruptions % UT | Duration (in periods) | Performance Criterion |
| 0 | 100 | 250P | <input type="checkbox"/> A <input type="checkbox"/> B <input checked="" type="checkbox"/> C <input type="checkbox"/> D |
| | | | |
| | | | |

APPENDIX I -- TEST SETUP PHOTOGRAPH

Photo of Power Line Conducted Emission Test



Photo of Radiated Emission Test

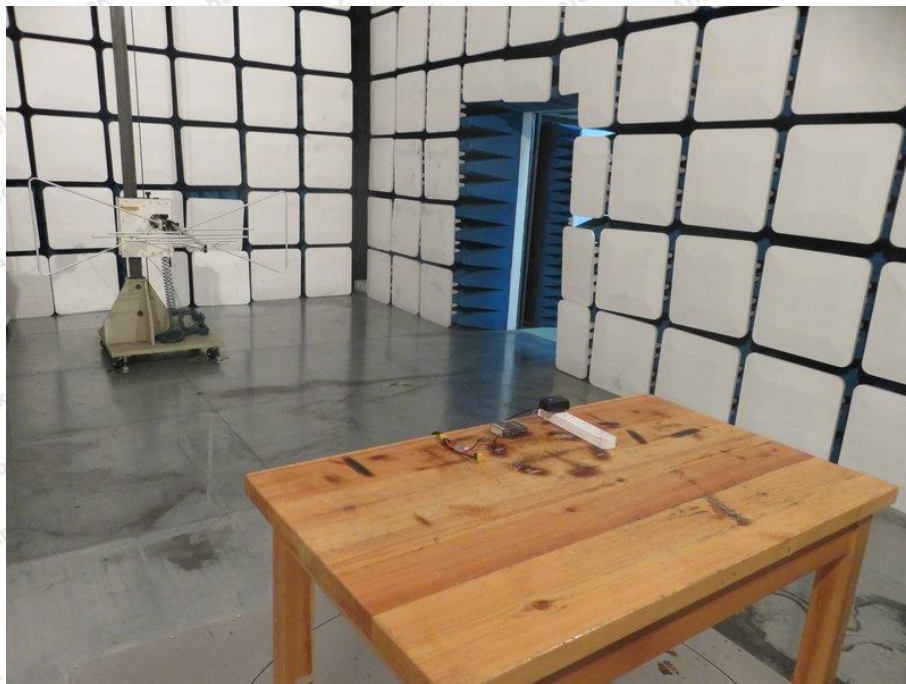

Photo of Flicker/ Harmonic Test



Photo of Electrostatic Discharge Immunity Test



Photo of RF Field Strength susceptibility Test



Photo of Electrical Fast Transient/Burst Immunity Test



Photo of Surge Immunity Test



Photo of Injected currents susceptibility Test

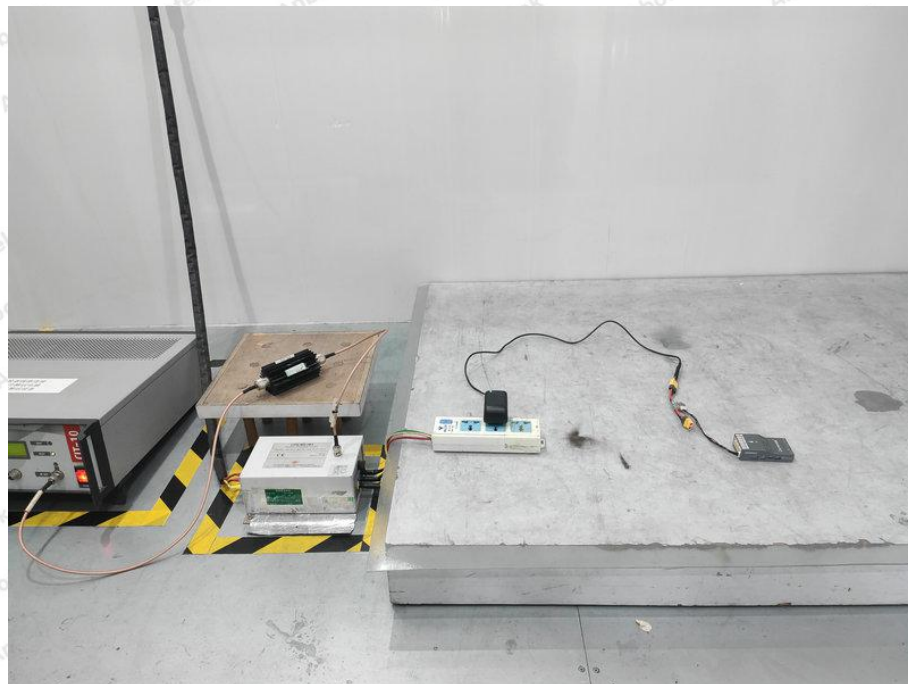
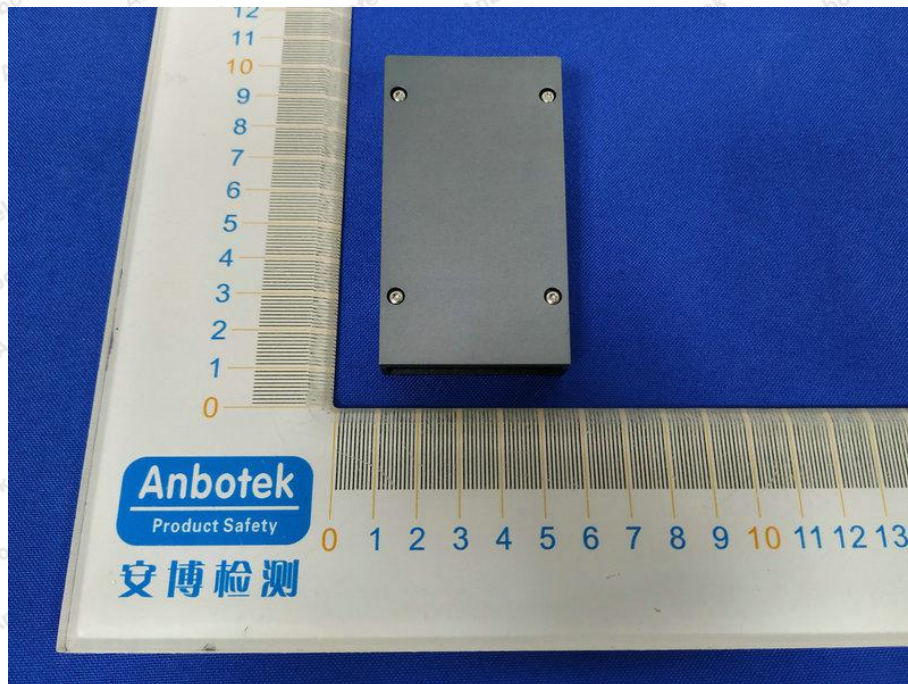
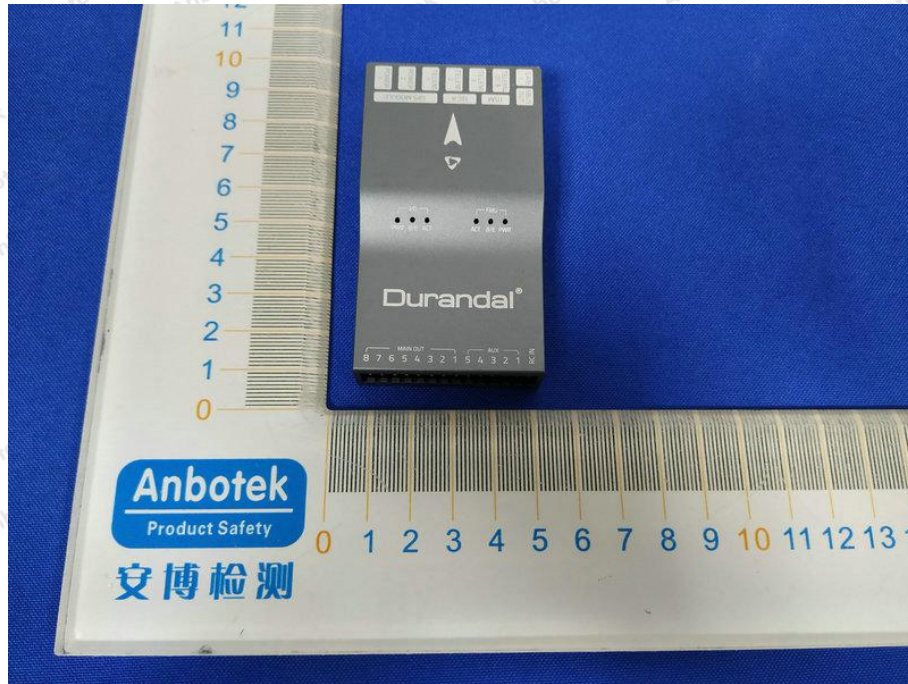
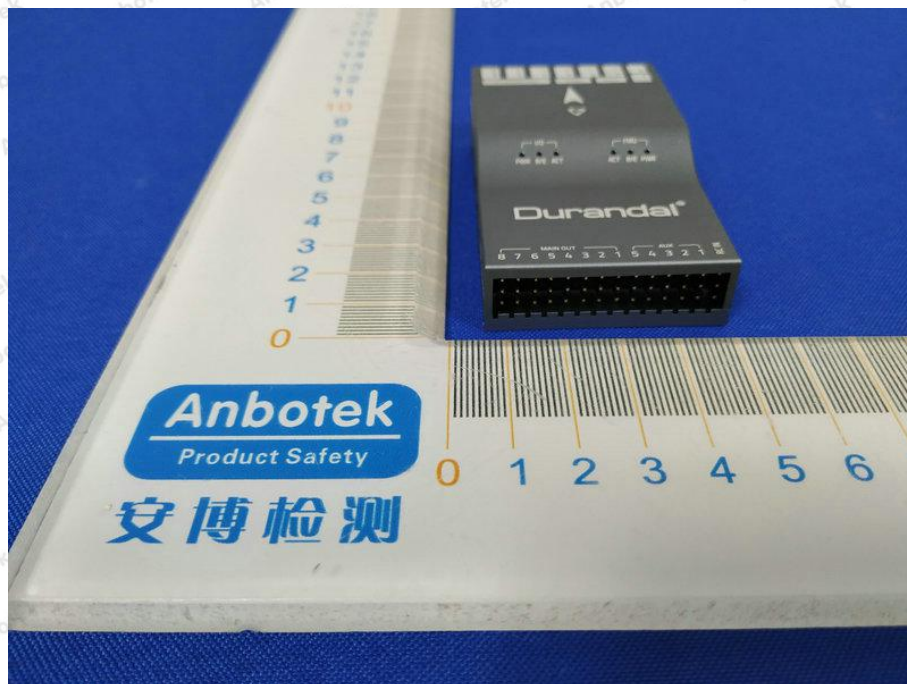
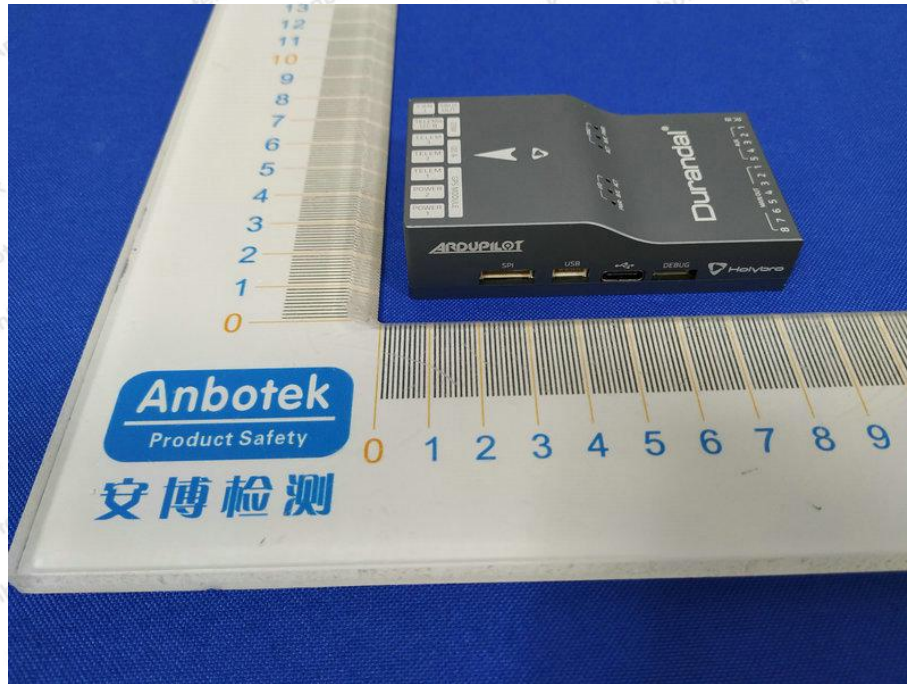

Photo of Voltage Dips and Interruptions Test



APPENDIX II -- EXTERNAL PHOTOGRAPH





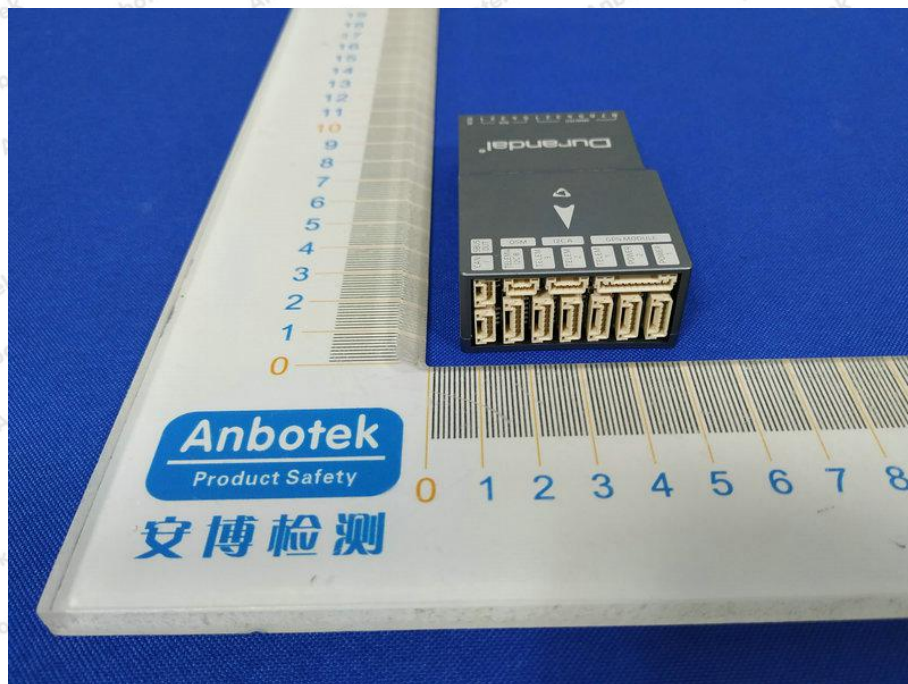
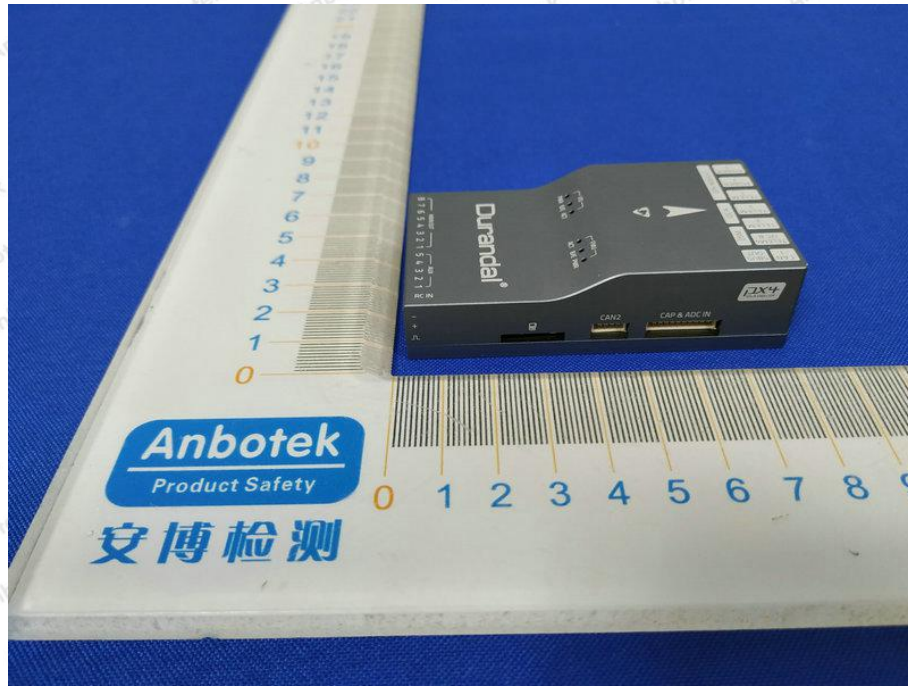

APPENDIX III -- INTERNAL PHOTOGRAPH

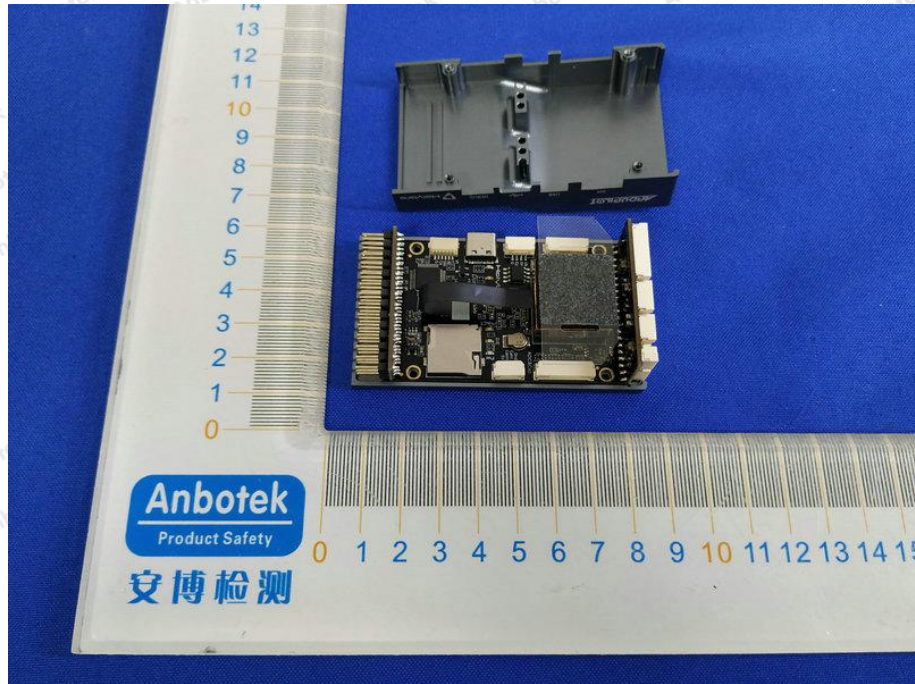



CE Label

1. The CE conformity marking must consist of the initials 'CE' taking the following form:

If the CE marking is reduced or enlarged, the proportions given in the above graduated drawing must be respected.

2. The CE marking must have a height of at least 5 mm except where this is not possible on account of the nature of the apparatus.

3. The CE marking must be affixed to the product or to its data plate. Additionally it must be affixed to the packaging, if any, and to the accompanying documents.

4. The CE marking must be affixed visibly, legibly and indelibly.

It must have the same height as the initials 'CE'.

----- End of Report -----

