

Timer allocation:
 PE9: TIM1_CH1: FMU-CH4
 PE11: TIM1_CH2: FMU-CH3
 PE13: TIM1_CH3: FMU-CH2
 PE14: TIM1_CH4: FMU-CH1
 PA15: TIM2_CH1: ALARM
 PB0: TIM3_CH3: GYRO1_DRDY
 PB1: TIM3_CH4: GYRO2_DRDY
 PB4: TIM3_CH1: ACCEL_DRDY
 PB5: TIM3_CH2: MAG_DRDY
 PD13: TIM4_CH2: FMU-CH5
 PD14: TIM4_CH3: FMU-CH6
 PD15: TIM4_CH4: spare

Note: MAG/ACCEL/GYRO_DRDY pins chosen for both timer capture and separate EXTI operation.
 EXTI0 - TIM3_CH3 - GYRO1
 EXTI1 - <free>
 EXTI2 - <free>
 EXTI3 - <free>
 EXTI4 - TIM3_CH1 - ACCEL
 EXTI5-9 - TIM3_CH2 - MAG

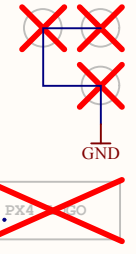

<http://www.oshwa.org/>
<http://creativecommons.org/licenses/by-sa/3.0/>

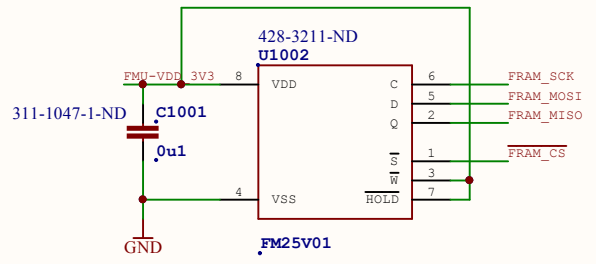
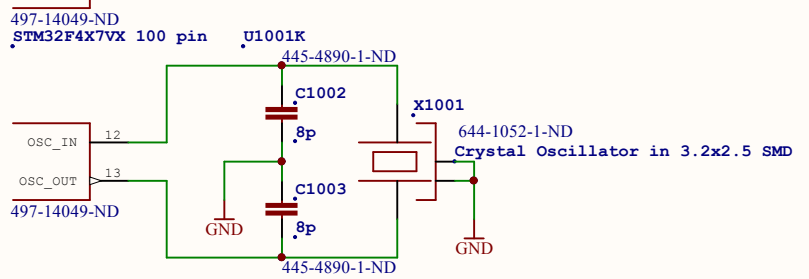
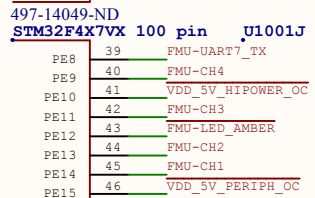
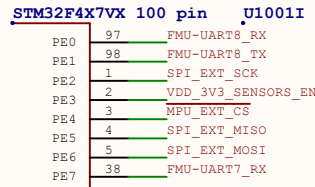
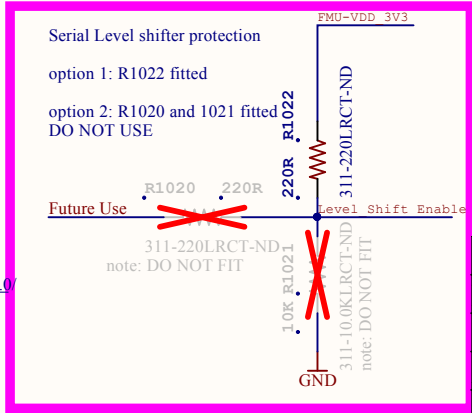
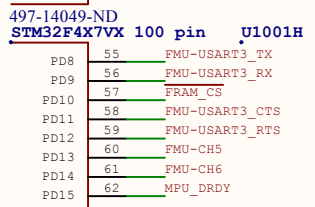
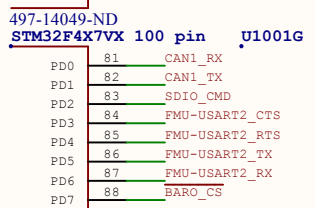
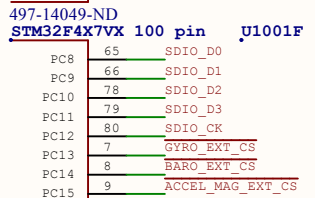
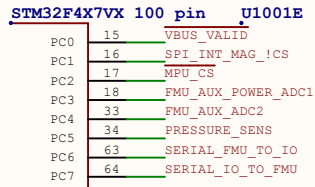

Title: FMU FMU3 REV C.Sch.Doc		
Date: 4/06/2015	Time: 1:19:18 PM	
Sheet:1 of: 10	Drawn By: Philip Rowse	3DRobotics
Approved: *	Checked By: *	

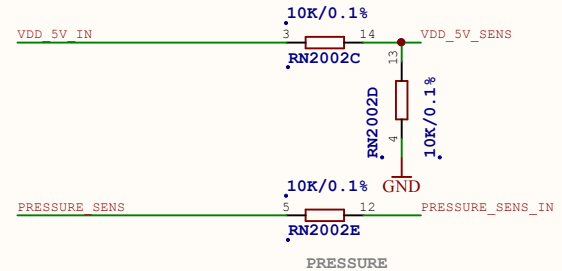
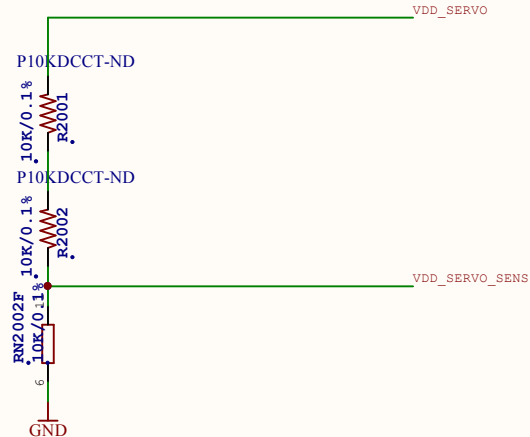
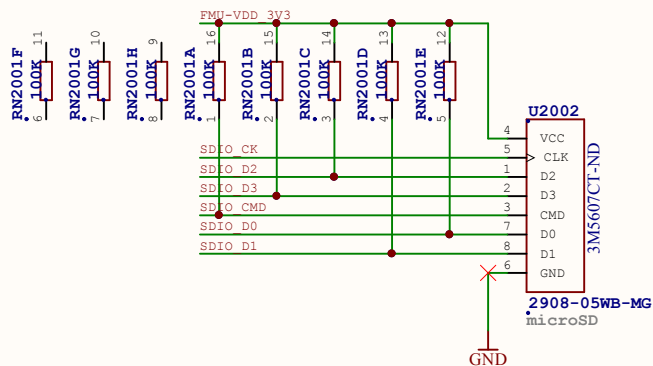
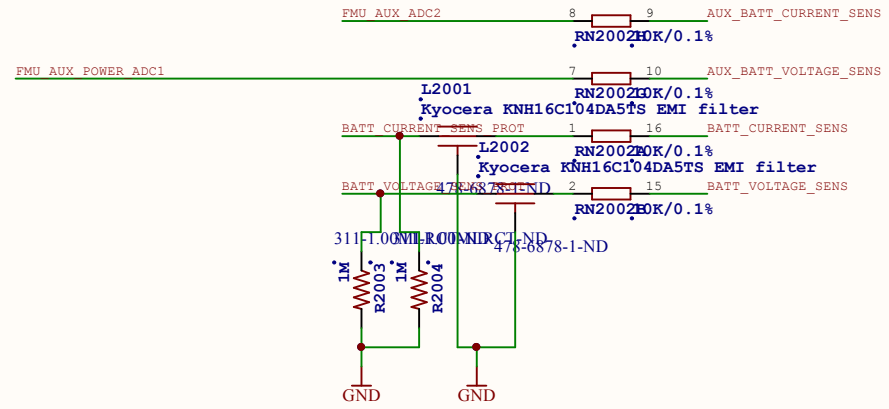
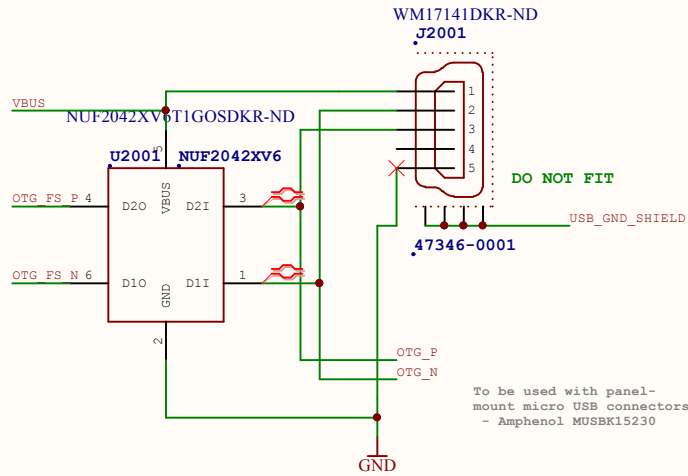

<http://www.oshwa.org/>
<http://creativecommons.org/licenses/by-sa/3.0/>

Title: SD USB FMU3 REV C.SchDoc	
Date: 4/06/2015	Time: 1:19:18 PM
Sheet:2 of: 10	Drawn By: Philip Rowse
Approved: *	Checked By: *



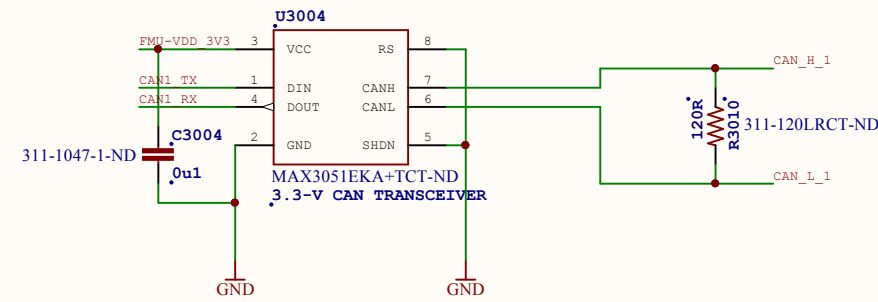
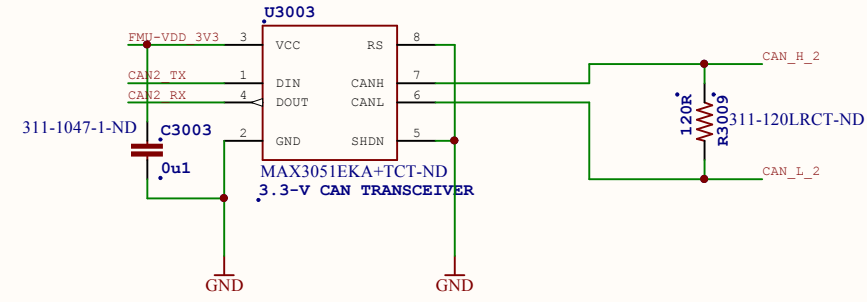
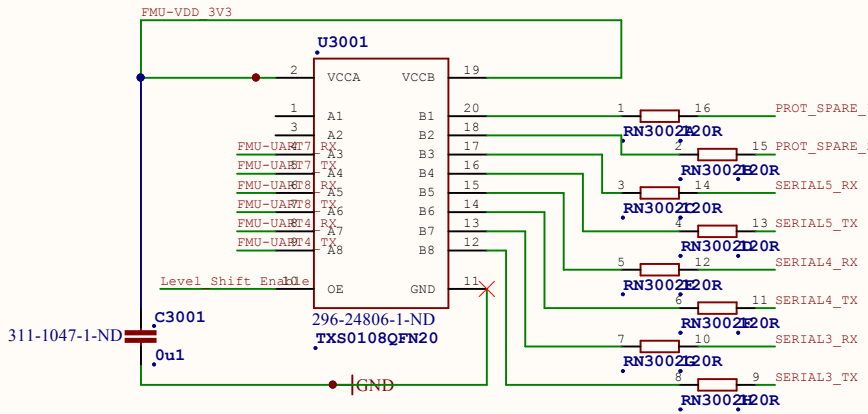
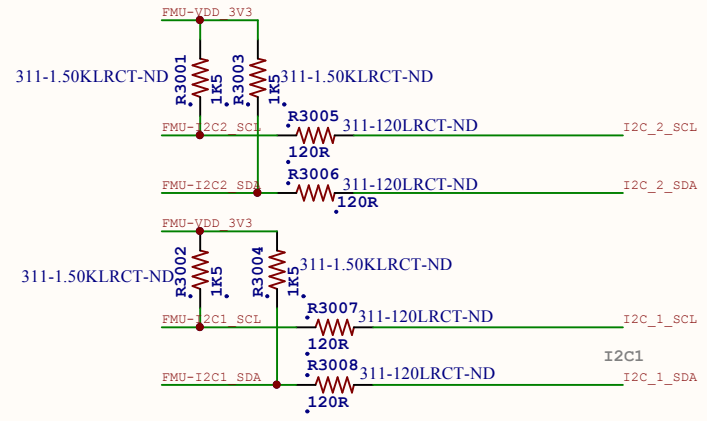
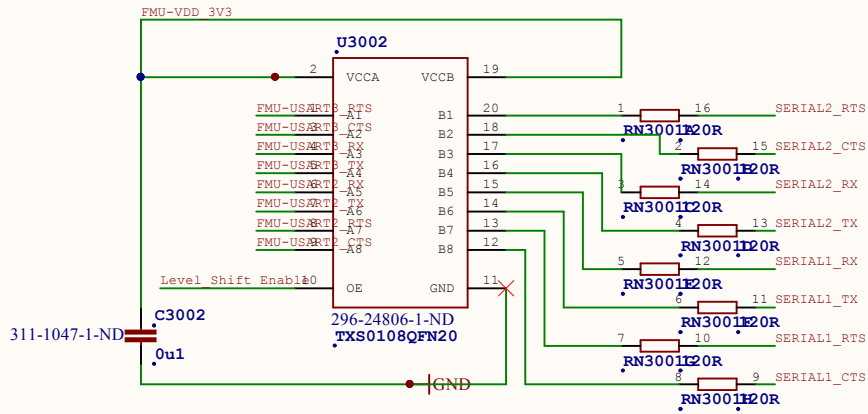

<http://www.oshwa.org/>

<http://creativecommons.org/licenses/by-sa/3.0/>

Title: SERIAL FMU3 REV C.SchDoc	
Date: 4/06/2015	Time: 1:19:18 PM
Sheet:3 of: 10	Drawn By: Philip Rowse
Approved: *	Checked By: *



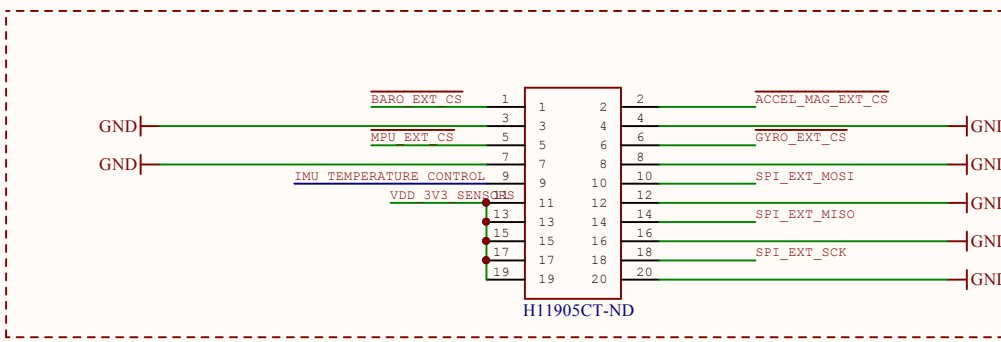
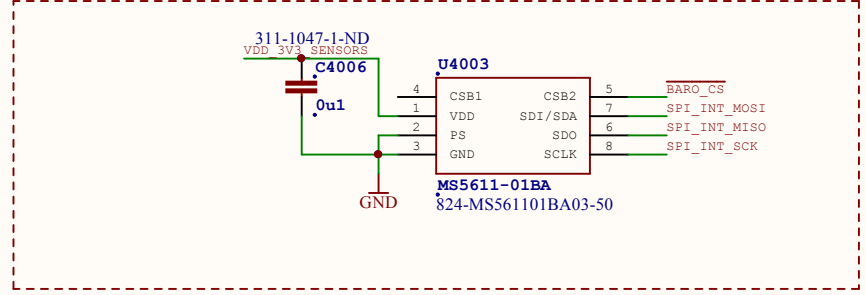
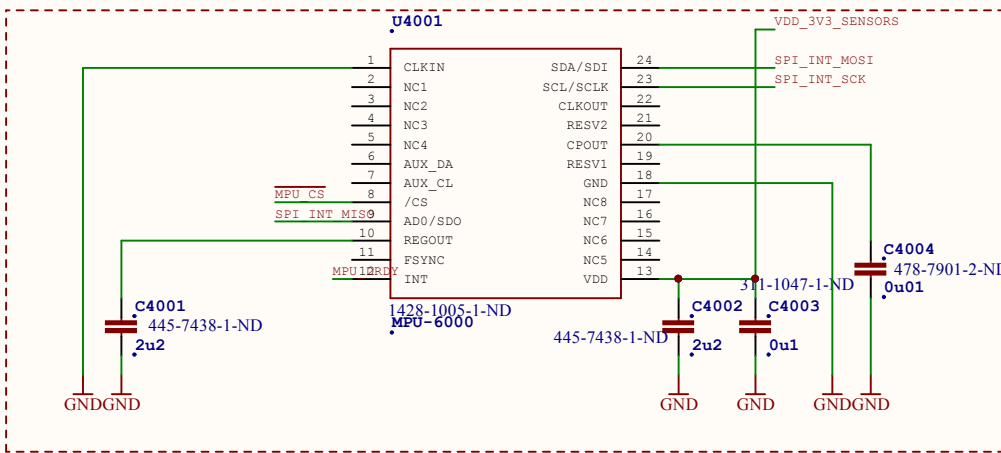
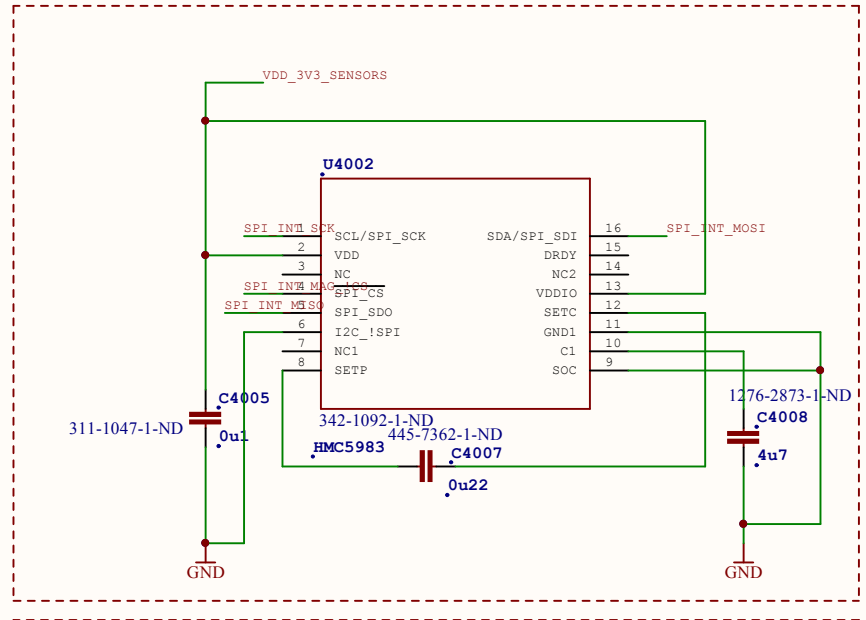
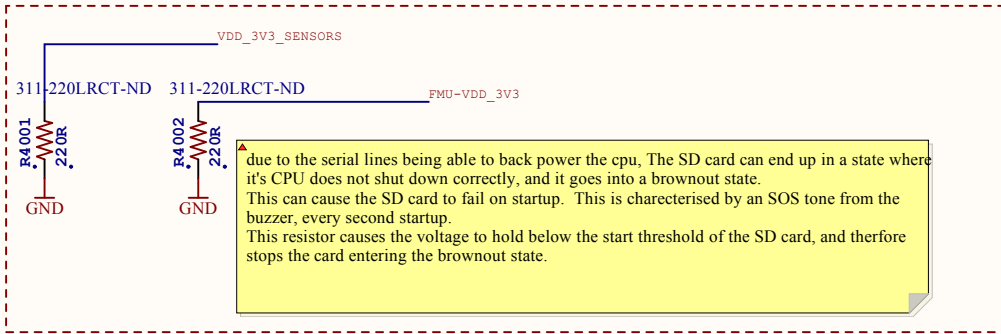

<http://www.oshwa.org/>

<http://creativecommons.org/licenses/by-sa/3.0/>

Title: SENSORS FMU3 REV C.SchDoc	
Date: 4/06/2015	Time: 1:19:18 PM
Sheet:4 of: 10	Drawn By: Philip Rowse
Approved: *	Checked By: *



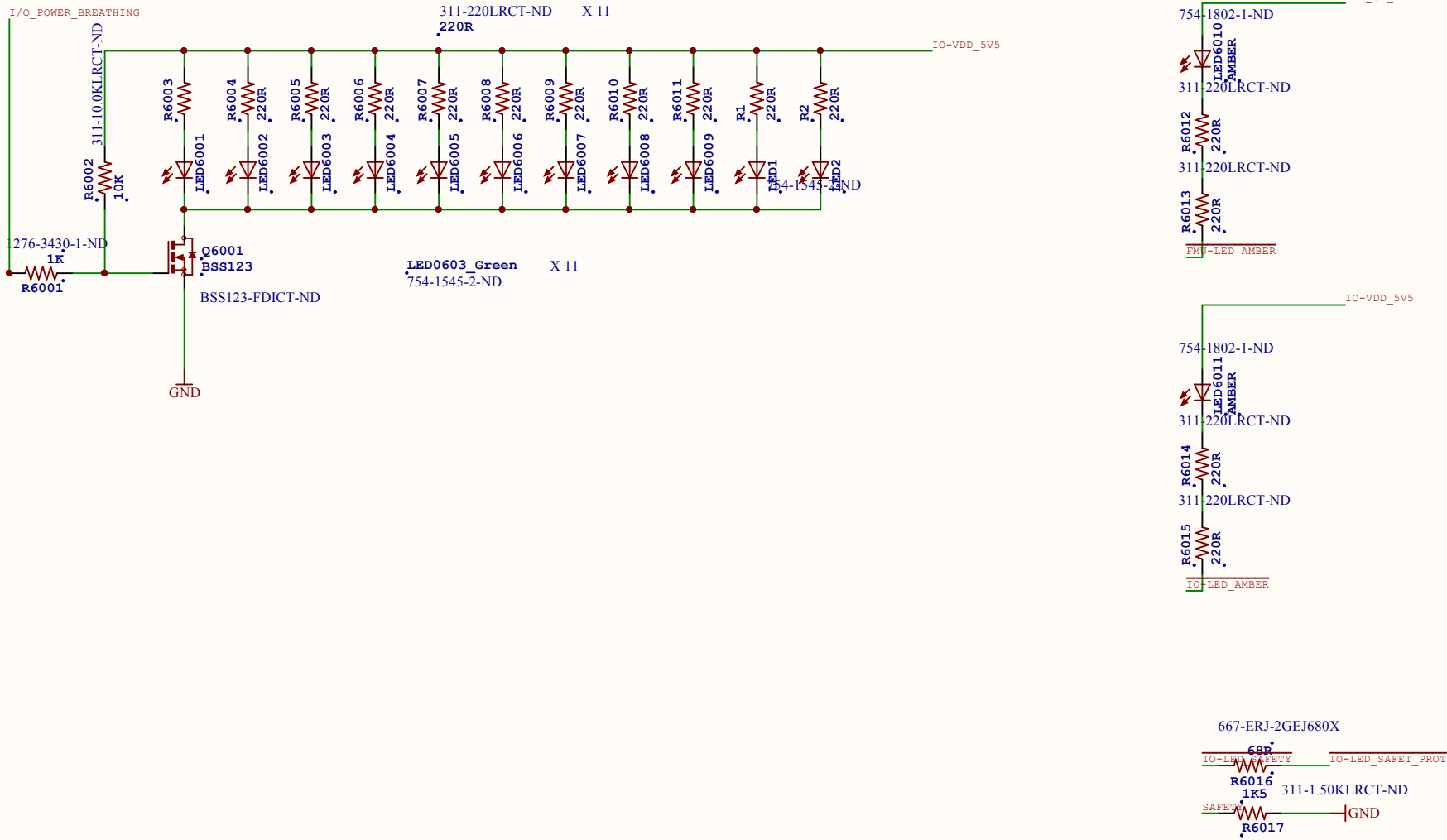

<http://www.oshwa.org/>
<http://creativecommons.org/licenses/by-sa/3.0/>

Title: LEDs FMU3 REV C.SchDoc		
Date: 4/06/2015	Time: 1:19:18 PM	
Sheet: 6 of: 10	Drawn By: Philip Rowse	3DRobotics
Approved: *	Checked By: *	

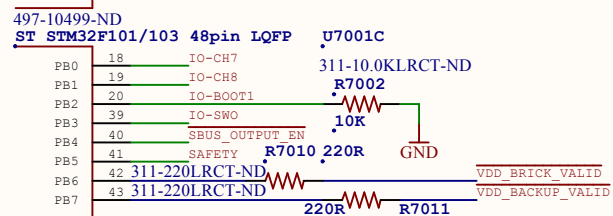
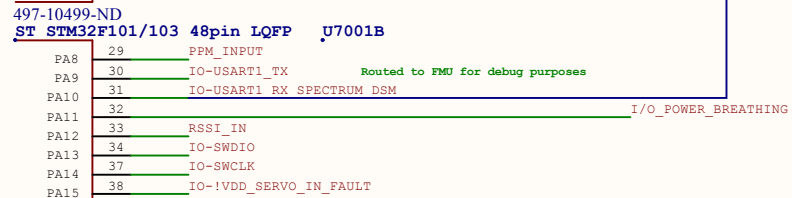
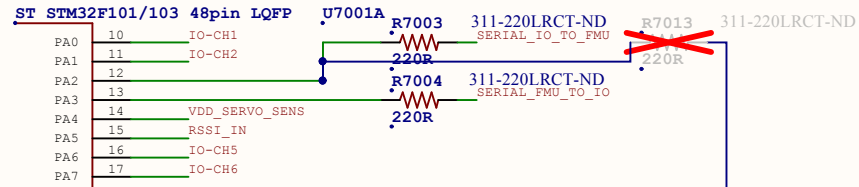

PixHawk 1:PC14 Floating
 PC15 Floating
 PixHawk 2:PC14 3.3v
 PC15 GND

Timer allocation:
 PA0: TIM2 CH1: IO-CH1
 PA1: TIM2 CH2: IO-CH2
 PB8: TIM4 CH3: IO-CH3
 PB9: TIM4 CH4: IO-CH4
 PA6: TIM3 CH1: IO-CH5
 PA7: TIM3 CH2: IO-CH6
 PB0: TIM3 CH3: IO-CH7
 PB1: TIM3 CH4: IO-CH8
 PA8: TIM1 CH1: PPM_IN
 PA11: TIM1 CH4: RSSI_IN

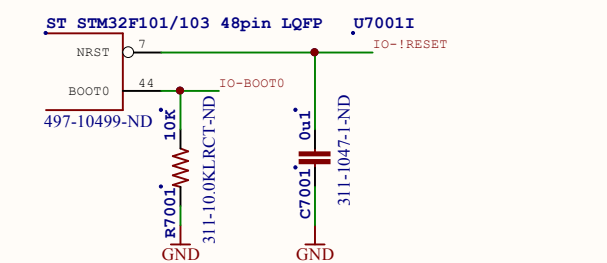
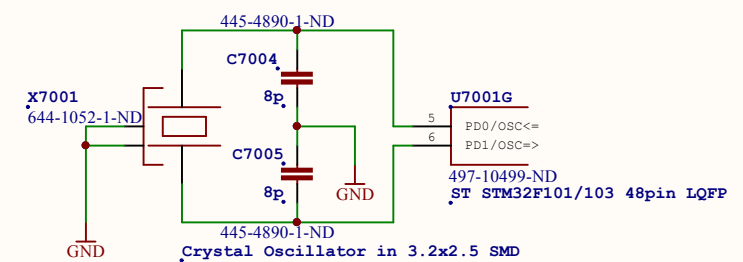
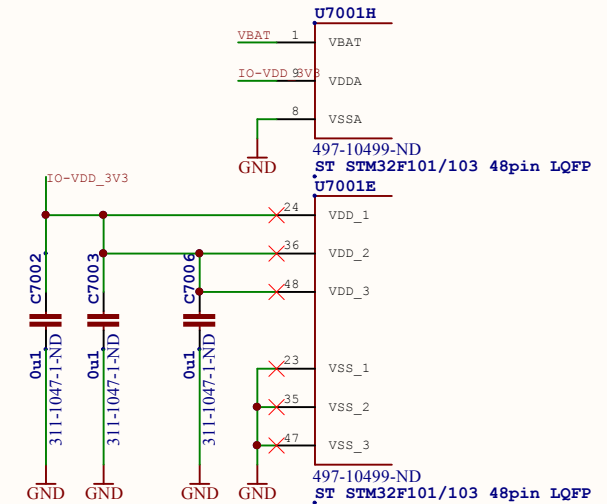

<http://www.oshwa.org/>
<http://creativecommons.org/licenses/by-sa/3.0/>

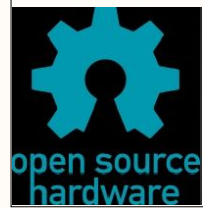

Title: IO FMU3 REV C.SchDoc		3DR
Date: 4/06/2015	Time: 1:19:18 PM	
Sheet: 7 of: 10	Drawn By: Philip Rowse	3DRobotics
Approved: *	Checked By: *	

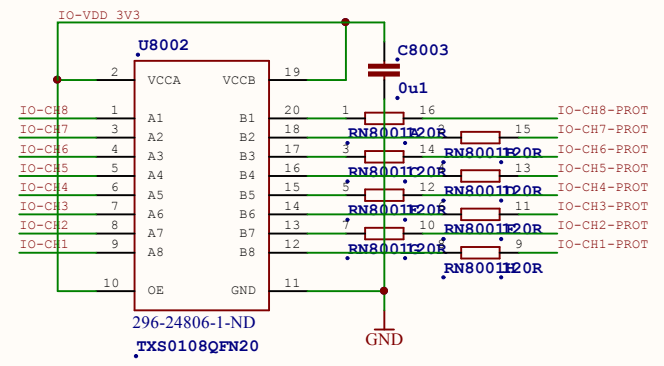
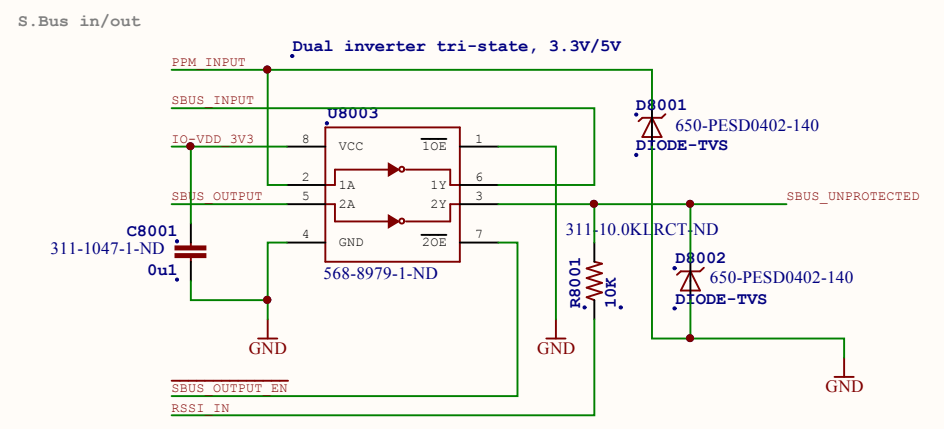
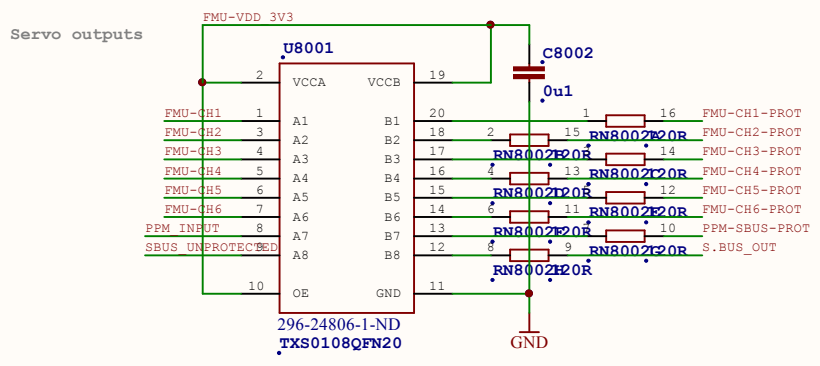

<http://www.oshwa.org/>
<http://creativecommons.org/licenses/by-sa/3.0/>

Title: PWM PPM FMU3 REV C.SchDoc	
Date: 4/06/2015	Time: 1:19:19 PM
Sheet:8 of: 10	Drawn By: Philip Rowse
Approved: *	Checked By: *



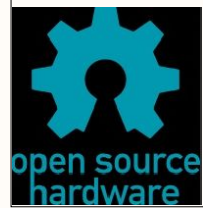
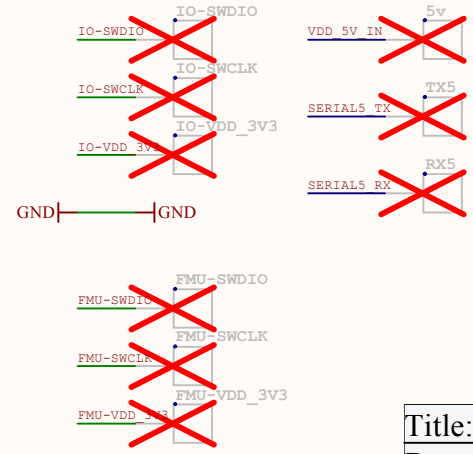
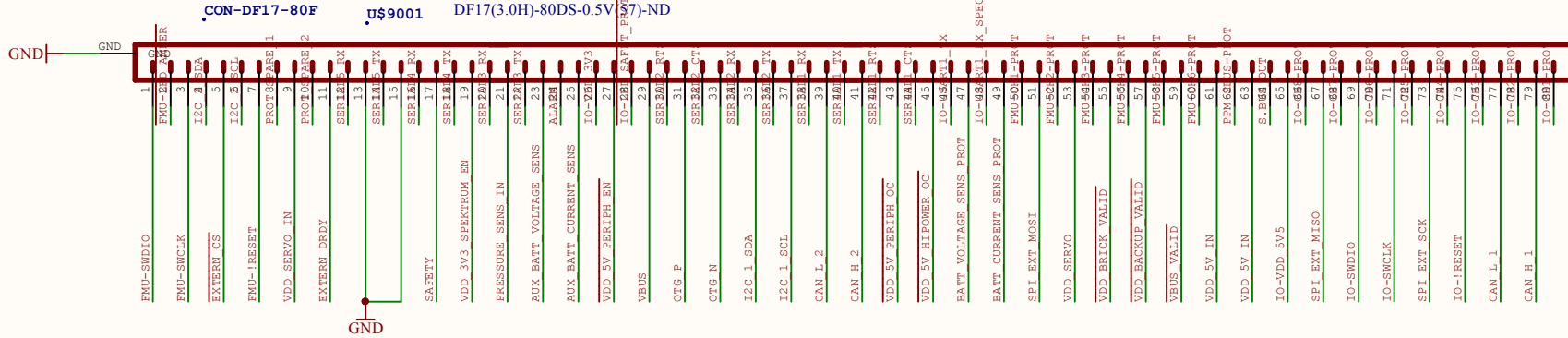

<http://www.oshwa.org/>
<http://creativecommons.org/licenses/by-sa/3.0/>

Title: 80PIN FMU3 REV C.SchDoc		
Date: 4/06/2015	Time: 1:19:19 PM	
Sheet:9 of: 10	Drawn By: Philip Rowse	3DRobotics
Approved: *	Checked By: *	

A

B

C

D

A

B

C

D

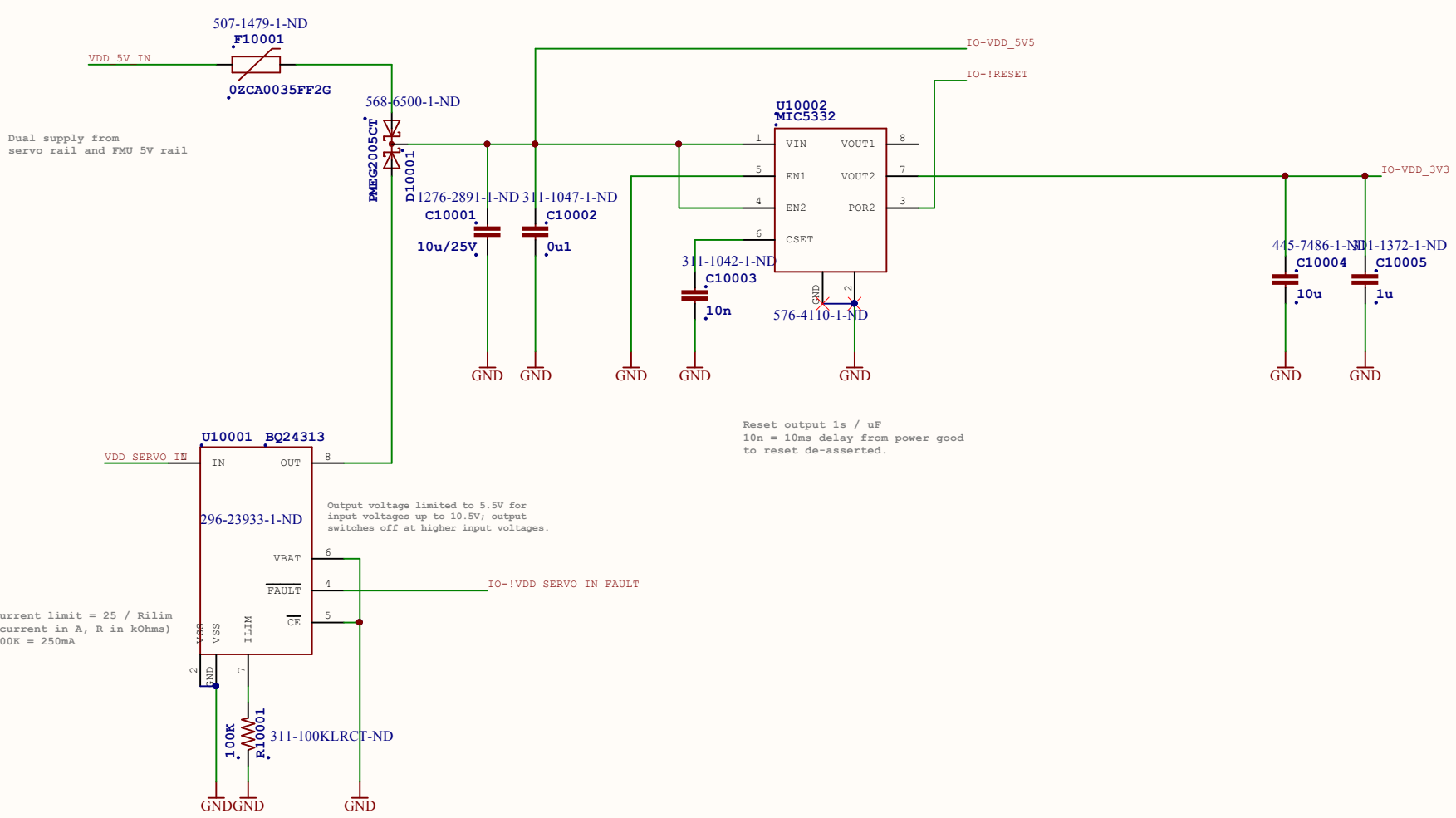

<http://www.oshwa.org/>
<http://creativecommons.org/licenses/by-sa/3.0/>

Title: IO PWR FMU3 REV C.SchDoc		
Date: 4/06/2015	Time: 1:19:19 PM	
Sheet:10 of: 10	Drawn By: Philip Rowse	3DRobotics
Approved: *	Checked By: *	

- 1. What
 - a.new revision of the FMU
- 2. Why
 - a.To fix a mechanical mounting issue found in the factory
- 3. Who
 - a.Production
- 4. When
 - a. URGENT
- 5. Milestones.
 - a.22th may 2015
- 6. Budget
 - a.Prototype to be manually manufactured, this will reduce time taken and derisk
- 7. Testing and programming plan
 - a.Testing as per existing FMU
- 8. Field upgrade plan
 - a.Bootloadable, No Change
- 9. Compliance
 - a.No Compliance changes
- 10. Accountability
 - a.Review to be signed off by Zach and Angus, with Clint signing off ME aspects

Changes for Rev D

Changed mechanical outline to allow for a mounting method that removes stress from IMU3
 Added a footprint for an I/O bypass resistor under the I/O chip. this is to allow prototyping a version that does not have the FMU while still using the "Spectrum" style input.
 Moved various components and traces to ensure safe edge distance
 reduced size of USB connector Pads to reduce risk of short with incorrectly placed USB connector.



<http://www.oshwa.org/>
<http://creativecommons.org/licenses/by-sa/3.0/>

Title: CHANGE FMU3 REV D.SchDoc		 3DRobotics
Date: 4/06/2015	Time: 1:19:19 PM	
Sheet:10 of: 10	Drawn By: Philip Rowse	
Approved: *	Checked By: *	