



Transport
Canada

Transports
Canada

TP 14371E

Transport Canada

Aeronautical Information Manual

(TC AIM)

RAC—Rules of the Air and Air Traffic Services

MARCH 19, 2026

Canada 

Transport Canada Aeronautical Information Manual (TC AIM)

Explanation of Changes

Effective—March 19, 2026

NOTES:

1. Editorial and format changes were made throughout the TC AIM where necessary, and those that were deemed insignificant in nature were not included in the “Explanation of Changes.”
2. The blue highlights in the manual represent the changes described in this section.

RAC

- (1) [RAC 4.2.11 – Visual Signals](#)
This section was updated for clarity.
 - (2) [RAC 4.4.4 – Taxiing](#)
This section was updated with new information.
 - (3) [RAC 4.4.7 – Visual Signals](#)
This section was updated for clarity.
 - (4) [RAC 9.2.2 – Terminal Arrival Area \(TAA\)](#)
This section was updated with new information.
-

Table of Contents

RAC—Rules of the Air and Air Traffic Services

183

1.0	General Information	183
1.1	Air Traffic Services	183
1.1.1	Air Traffic Control (ATC) and Information Services	183
1.1.2	Flight Advisory and Information Services	184
1.1.2.1	Flight Information Centres (FICs)	184
1.1.2.2	Flight Service Stations (FSSs)	184
1.1.2.3	Flight Information Centres (FICs) and Flight Service Stations (FSSs)	185
1.1.2.4	International Flight Service Station (IFSS)	185
1.1.3	Arctic Territories	185
1.1.4	Military Flight Advisory Unit (MFAU)	185
1.2	Services Other Than Air Traffic Services (ATS)	186
1.2.1	Universal Communications (UNICOM)	186
1.2.2	Airport Radio/Community Aerodrome Radio Station	186
1.2.3	Private Advisory Stations (PAS)—Controlled Airports	186
1.2.4	Apron Advisory Service	187
1.3	Automatic Terminal Information Service (ATIS)	187
1.4	Use of Term “Ceiling and Visibility OK (CAVOK)”	187
1.5	ATS Surveillance Service	188
1.5.1	General	188
1.5.2	Procedures	188
1.5.3	Air Traffic Service (ATS) Surveillance Traffic Information	188
1.5.4	ATS Surveillance Navigation Assistance to Visual Flight Rules (VFR) Flights	189
1.5.5	Obstacle Clearance During Vectors	189
1.5.6	Misuse of Vectors	190
1.5.7	Canadian Forces Radar Assistance	190
1.5.8	The Use of ATS Surveillance in the Provision of Aerodrome Advisory Service (AAS) and Remote Aerodrome Advisory Service (RAAS) by Flight Service Stations (FSS)	190
1.6	Air Traffic Control (ATC) Clearances, Instructions and Information	190
1.6.1	Inability to Issue Clearance	191
1.6.1.1	Examples	191
1.7	Air Traffic Control (ATC) Service Priority	194
1.7.1	Normal Conditions	194
1.7.2	Special Conditions	194
1.7.3	Minimum Fuel Advisory	194
1.8	Collision Avoidance—Right of Way (<i>Canadian Aviation Regulations</i> [CARs])	194
1.9	Aerobatic Flight (<i>Canadian Aviation Regulations</i> [CARs] 602.27 and 602.28)	195
1.10	Conservation	196
1.10.1	Fur and Poultry Farms	196
1.10.2	Protection of Wildlife	196
1.10.3	National, Provincial and Municipal Parks, Reserves and Refuges	196
2.0	Airspace – Requirements and Procedures	196
2.1	General	196
2.2	Canadian Domestic Airspace (CDA)	196
2.2.1	Northern and Southern Domestic Airspace	196
2.3	High- and Low-Level Airspace	197
2.3.1	Cruising Altitudes and Flight Levels Appropriate to Aircraft Track	197
2.4	Flight Information Regions (FIRs)	197
2.5	Controlled Airspace	198
2.5.1	Use of Controlled Airspace by Visual Flight Rules (VFR) Flights	198
2.5.2	Aircraft Speed Limit Order	198
2.6	High-Level Controlled Airspace	199
2.7	Low-Level Controlled Airspace	199
2.7.1	Low-Level Airways	199
2.7.2	Control Area Extensions	200

2.7.3	Control Zones	200
2.7.4	Visual Flight Rules (VFR) Over-the-Top	201
2.7.5	Transition Areas	202
2.7.6	Terminal Control Areas	202
2.8	Airspace Classification	202
2.8.1	Class A Airspace.....	203
2.8.2	Class B Airspace	203
2.8.3	Class C Airspace	204
2.8.4	Class D Airspace	204
2.8.5	Class E Airspace.....	204
2.8.6	Class F Airspace	205
2.8.6.1	Charting of Class F Airspace.....	205
2.8.6.2	Danger Area (International Waters)	205
2.8.6.3	Advisory Airspace	205
2.8.6.4	Restricted Airspace	206
2.8.6.5	Joint-Use Airspace	206
2.8.6.6	NOTAM	206
2.8.7	Class G Airspace	206
2.9	Other Airspace Divisions	206
2.9.1	Altitude Reservation	206
2.9.2	Temporary Flight Restrictions—Forest Fires	207
2.9.3	Flight Operations Over or in the Vicinity of Nuclear Power Plants.....	207
2.9.4	Military Operations Areas.....	207
2.10	Altimeter Setting Region	207
2.11	Standard Pressure Region	207
2.12	Mountainous Regions	208
2.13	Emergency Communications and Security.....	209
3.0	Flight Planning.....	209
3.1	General	209
3.2	Pilot Briefing Service	209
3.3	Aeronautical Information	209
3.4	Weight and Balance Control	210
3.4.1	Definitions	210
3.4.2	Weight Control	211
3.4.3	Balance	211
3.4.4	Operational Requirements.....	211
3.4.5	Computerized Systems.....	212
3.4.6	Segmented Weights.....	212
3.4.6.1	Derivation of Segmented Weights.....	212
3.4.7	Computation of Passenger and Baggage Weights.....	212
3.4.8	Fuel and Oil Weights.....	214
3.5	Flight Plans and Flight Itineraries	215
3.5.1	When Required	215
3.5.2	Filing a Flight Plan or Flight Itinerary (<i>Canadian Aviation Regulation</i> [CAR] 602.75)	215
3.5.3	Flight Plan Requirements—Flights Between Canada and a Foreign State	215
3.5.4	Opening a Visual Flight Rules (VFR) Flight Plan or Flight Itinerary	215
3.6	Changes To The Information In A Flight Plan Or Flight Itinerary	215
3.6.1	Visual Flight Rules (VFR) Flight Plan or Flight Itinerary	216
3.6.2	Instrument Flight Rules (IFR) Flight Plan or Flight Itinerary	216
3.7	Composite Flight Plan Or Flight Itinerary—Visual Flight Rules (VFR) And Instrument Flight Rules (IFR)	216
3.8	Defence Visual Flight Rules (VFR) Flight Plans and Defence Flight Itineraries (<i>Canadian Aviation Regulation</i> [CAR] 602.145).....	216
3.9	Intermediate Stops	217
3.9.1	Consecutive Instrument Flight Rules (IFR) Flight Plans	217
3.10	Cross-country Instrument Training Flights	217
3.11	Closing a Flight Plan	217
3.11.1	Arrival Report	218
3.11.2	Closing of a Flight Plan or Flight Itinerary Prior to Landing	218
3.12	Fuel Requirements	218

3.12.1	Visual Flight Rules (VFR) Flight	218
3.12.2	Instrument Flight Rules (IFR) Flight	218
3.13	Requirements for Alternate Aerodrome — Instrument Flight Rules (IFR) Flight	219
3.13.1	Alternate Aerodrome Weather Minima Requirements	219
3.14	Completion of Canadian Flight Plans and Flight Itineraries and International Civil Aviation Organization (ICAO) Flight Plans	220
3.14.1	General	220
3.14.2	Canadian	220
3.14.3	International Civil Aviation Organization (ICAO)	220
3.14.4	Instructions for Completing the Form	221
3.14.4.1	General	221
3.14.4.2	Instructions for Insertion of ATS Data	221
3.15	Contents of a Flight Plan and Flight Itinerary	221
3.15.1	Item 7: Aircraft Identification (not exceeding seven alphanumeric characters and without hyphens or symbols)	221
3.15.2	Item 8: Flight Rules and Type of Flight	221
3.15.2.1	Flight Rules (one character) (Canadian and ICAO)	221
3.15.2.2	Type of Flight (up to two characters, as applicable)	222
3.15.3	Item 9: Number and Type of Aircraft and Wake Turbulence Category	222
3.15.3.1	Number of Aircraft (one or two characters)	222
3.15.3.2	Type of Aircraft (two to four characters)	222
3.15.3.3	International Civil Aviation Organization (ICAO) Wake Turbulence Category (one character)	222
3.15.4	Item 10: Equipment (Canadian and International Civil Aviation Organization (ICAO))	222
3.15.4.1	Radio Communication, Navigation and Approach Aid Equipment and Capabilities	222
3.15.4.2	Surveillance Equipment and Capabilities	223
3.15.5	Item 13: Departure Aerodrome and Time	224
3.15.5.1	Departure Aerodrome (maximum four characters)	224
3.15.5.2	Time (maximum four characters)	224
3.15.6	Item 15: Cruising Speed, Altitude/Level and Route	224
3.15.6.1	Flights Along Designated Air Traffic Service (ATS) Routes:	225
3.15.6.2	Flights Outside Designated Air Traffic Service (ATS) Routes:	225
3.15.7	Item 16: Destination Aerodrome, Total Estimated Elapse Time (EET), Search And Rescue (SAR) Time (for flights in Canada only) and Destination Alternate Aerodrome(s)	226
3.15.7.1	Destination Aerodrome and Total Estimated Elapse Time (EET) (maximum 10 characters)	226
3.15.7.2	Destination Alternate Aerodrome(s)	226
3.15.8	Item 18: Other Information	227
3.15.9	Item 19: Supplementary Information	229
3.15.9.1	Endurance	229
3.15.9.2	Persons On Board	229
3.15.9.3	Emergency and Survival Equipment	229
4.0	Airport Operations	231
4.1	General	231
4.1.1	Wake Turbulence	232
4.1.2	Noise Abatement	233
4.1.3	Preferential Runway Assignments	234
4.1.4	Runway Protected Area	234
4.2	Departure Procedures — Controlled Airports	234
4.2.1	Automatic Terminal Information Service (ATIS) Broadcasts	234
4.2.2	Clearance Delivery	234
4.2.3	Radio Checks	235
4.2.4	Requests for Push-back or Power-back	235
4.2.5	Taxi Information	235
4.2.5.1	Oblique Angle Intersection Use	235
4.2.5.2	Best Practices for Pilots	236
4.2.6	Taxi Holding Positions	236
4.2.7	Taxiway Holding Positions During Instrument Flight Rules (IFR) Operations	236
4.2.7.1	Glide Path Signal Protection Procedures	236
4.2.8	Take-off Clearance	236
4.2.8.1	Air Traffic Control (ATC) Phraseology When a Runway Is Temporarily Shortened Due to Construction	237
4.2.8.2	Clearance for Aborting a Takeoff	237

4.2.9	Release from Tower Frequency	237
4.2.10	Departure Procedures - No Radio (NORDO) Aircraft	237
4.2.11	Visual Signals	237
4.2.12	Departure Procedures – Receiver Only (RONLY) Aircraft	238
4.3	Traffic Circuits — Controlled Aerodromes	238
4.4	Arrival Procedures — Controlled Airports	239
4.4.1	Initial Contact	239
4.4.2	Initial Clearance	239
4.4.3	Landing Clearance	240
4.4.3.1	Air Traffic Control (ATC) Phraseology When a Runway Is Temporarily Shortened Due to Construction	240
4.4.4	Taxiing	241
4.4.5	Arrival Procedures – No Radio (NORDO) Aircraft	241
4.4.6	Arrival Procedures – Receiver Only (RONLY) Aircraft	241
4.4.7	Visual Signals	242
4.4.8	Communications Failure - Visual Flight Rules (VFR)	242
4.4.9	Operations on Intersecting Runways	242
4.4.10	High Intensity Runway Operations (HIRO).....	245
4.5	Aircraft Operations—Uncontrolled Aerodromes	245
4.5.1	General.....	245
4.5.2	Traffic Circuit Procedures — Uncontrolled Aerodromes	246
4.5.3	Helicopter Operations	249
4.5.4	Mandatory Frequency (MF)	249
4.5.5	Aerodrome Traffic Frequency (ATF)	250
4.5.6	Use of Mandatory Frequency (MF) and Aerodrome Traffic Frequency (ATF)	250
4.5.7	Visual Flight Rules (VFR) Communication Procedures at Uncontrolled Aerodromes with Mandatory Frequency (MF) and Aerodrome Traffic Frequency (ATF) Areas	251
4.5.8	Aircraft Without Two-Way Radio (No Radio [NORDO]/Receiver Only [RONLY]).....	251
4.5.8.1	Prior Arrangements	251
4.5.8.2	Traffic Circuits - No Radio [NORDO]/Receiver Only [RONLY]	252
4.5.8.3	Receiver Only (RONLY)	252
4.6	Helicopter Operations at Controlled Airports	252
4.7	Published VFR Routes and VFR Checkpoints.....	252
5.0	Visual Flight Rules (VFR) En Route Procedures	253
5.1	Monitoring, Broadcasting on 126.7 MHz and Position Reporting En Route	253
5.2	Acknowledgement of Clearances	254
5.3	Altitudes and Flight Levels — Visual Flight Rules (VFR)	254
5.4	Minimum Altitudes—Visual Flight Rules (VFR) (<i>Canadian Aviation Regulations</i> [CARs] 602.14 and 602.15).....	254
5.5	Minimum Altitudes — Overflying Aerodromes [<i>Canadian Aviation Regulations</i> [CARs] 602.96(4)and(5)].....	254
5.6	Controlled Visual Flight Rules (CVFR) Procedures	255
5.7	En route Air Traffic Service (ATS) Surveillance	255
5.8	Visual Flight Rules (VFR) Operations Within Class C airspace	255
6.0	Instrument Flight Rules (IFR) — General	256
6.1	Air Traffic Control (ATC) Clearance	256
6.2	Instrument Flight Rules (IFR) Flights in Visual Meteorological Conditions (VMC)	256
6.2.1	Instrument Flight Rules (IFR) Clearance with Visual Flight Rules (VFR) Restrictions	256
6.2.2	Visual Flight Rules (VFR) Release of an Instrument Flight Rules (IFR) Aircraft	257
6.3	Emergencies and Equipment Failures — Instrument Flight Rules (IFR)	257
6.3.1	Declaration of Emergency	257
6.3.2	Two-Way Communications Failure	257
6.3.2.1	General	257
6.3.2.2	Instrument Flight Rules (IFR) Flight Plan	257
6.3.3	Reporting Malfunctions of Navigation and Communications Equipment	258
6.3.4	Fuel Dumping	259
6.4	Instrument Flight Rules (IFR) Separation	259
6.4.1	General	259
6.4.2	Vertical Separation — General	259
6.4.3	Vertical Separation Between Flight Levels and Altitudes Above Sea Level (ASL)	259
6.4.4	Longitudinal Separation—Distance-Based	259

- 6.4.5 Lateral Separation — General 259
- 6.4.6 Lateral Separation — Airways and Tracks 259
- 6.4.7 Lateral Separation — Instrument Approach Procedure 260
- 6.5 Visual Separation 260**
 - 6.5.1 General 260
 - 6.5.2 Speed Control Instructions on Departure 260
 - 6.5.3 Controller-Applied Visual Separation 260
 - 6.5.4 Pilot-Applied Visual Separation 260
- 6.6 Development of Instrument Procedures 261**
- 7.0 Instrument Flight Rules – Departure Procedures 261**
 - 7.1 Aerodrome Operations 261**
 - 7.2 Automatic Terminal Information Service (ATIS) Broadcasts 261**
 - 7.3 Initial Contact 261**
 - 7.4 Instrument Flight Rules (IFR) Clearances 261**
 - 7.5 PRE-TAXI CLEARANCE (PTC) PROCEDURES AT STAFFED FLIGHT SERVICE STATION (FSS) SITES 261**
 - 7.6 Standard Instrument Departure (SID) 262**
 - 7.7 Noise Abatement Procedures — Departure 263**
 - 7.7.1 General 263
 - 7.7.2 Noise Preferential Runways 263
 - 7.7.3 Noise Abatement Departure Procedure (NADP) 264
 - 7.7.3.1 NADP 1 (Criteria for a Close-in Noise-sensitive Area) Description 264
 - 7.7.3.2 NADP 2 (Criteria for a More Distant Noise-sensitive Area) Description 265
 - 7.8 Obstacle and Terrain Clearance 265**
 - 7.8.1 Visual Climb Over The Airport (VCOA) 266
 - 7.8.2 Low, Close-in Obstacles 266
 - 7.9 Release from Tower Frequency 267**
 - 7.10 Instrument Flight Rules (IFR) Departures from Uncontrolled Airports 267**
 - 7.11 Alerting Service Instrument Flight Rules (IFR) Departures from Uncontrolled Airports 267**
- 8.0 Instrument Flight Rules (IFR) – En Route Procedures 267**
 - 8.1 Position Reports 267**
 - 8.2 Mach Number/True Airspeed—Clearances and Reports 268**
 - 8.2.1 Mach Number 268
 - 8.2.2 True Airspeed (TAS) 268
 - 8.3 Altitude Reports 268**
 - 8.4 Climb or Descent 269**
 - 8.4.1 General 269
 - 8.4.2 Visual Climb and Descent 269
 - 8.4.2.1 General 269
 - 8.4.2.2 Visual Separation from Other Aircraft 269
 - 8.5 Minimum Instrument Flight Rules (IFR) Altitudes 269**
 - 8.6 Air Traffic Control (ATC) Assignment of Altitudes 270**
 - 8.6.1 Minimum Instrument Flight Rules (IFR) Altitude 270
 - 8.6.1.1 Distance Measuring Equipment (DME) Intersections on a Minimum En-Route Altitude (MEA) 270
 - 8.6.2 Altitudes and Direction of Flight 271
 - 8.7 “1 000-ft-on-Top” Instrument Flight Rules (IFR) Flight 271**
 - 8.8 Clearances—Leaving or Entering Controlled Airspace 271**
 - 8.9 Clearance Limit 272**
 - 8.10 Class G Airspace—Recommended Operating Procedures—En-Route 272**
- 9.0 Instrument Flight Rules (IFR) — Arrival Procedures 272**
 - 9.1 Automatic Terminal Information Service (ATIS) Broadcasts 272**
 - 9.2 Standard Terminal Arrival (STAR), Minimum Sector Altitude (MSA) and Terminal Arrival Area (TAA) 272**
 - 9.2.1 Minimum Sector Altitude (MSA) 272
 - 9.2.2 Terminal Arrival Area (TAA) 273
 - 9.2.3 Standard Terminal Arrival (STAR) 278
 - 9.2.3.1 Conventional Standard Terminal Arrival (STAR) 279
 - 9.2.3.2 Performance-based Navigation (PBN) Standard Terminal Arrival (STAR) 279
 - 9.2.3.3 Flight Planning 279

9.2.3.4	Procedure Identification	279
9.2.3.5	Altitude Restrictions	280
9.2.3.6	Speed Restrictions	280
9.2.3.7	Operating Procedures	280
9.2.3.8	Top of Descent (TOD)	280
9.2.3.9	Descent Planning.....	280
9.2.3.10	Closed Standard Terminal Arrival (STAR) Procedures	281
9.2.3.11	Open Standard Terminal Arrival (STAR) Procedures	281
9.2.3.12	Transitioning from an Open Standard Terminal Arrival (STAR) to an Approach Procedure.....	281
9.2.3.13	Approach Clearances.....	282
9.2.3.14	Vectors to Final.....	282
9.2.3.15	Amending Routes	282
9.2.3.16	Direct Routings to an Initial Approach Waypoint (IAWP)/Intermediate Waypoint (IWP)	283
9.2.3.17	Cancelling Standard Terminal Arrival (STAR) Procedures	283
9.2.3.18	Communication Failures on a Standard Terminal Arrival (STAR) Procedure.....	283
9.3	Approach Clearance	283
9.4	Descent Out of Controlled Airspace	284
9.5	Advance Notice of Intent in Minimum Weather Conditions	284
9.6	Contact and Visual Approaches	284
9.6.1	Contact Approach	284
9.6.2	Visual Approach	285
9.6.2.1	Missed Approach.....	286
9.7	Arrivals	286
9.7.1	General	286
9.7.2	ATS Surveillance Required	286
9.7.3	Speed Adjustment – ATS Surveillance-Controlled Aircraft	286
9.7.4	Precision Radar Approaches	287
9.8	Initial Contact with Control Towers	287
9.9	Approach Position Reports— Controlled Airports	287
9.10	Control Transfer— Instrument Flight Rules (IFR) Units to Towers	287
9.11	Initial Contact with Air-Ground Facility at Uncontrolled Aerodromes	288
9.12	Instrument Flight Rules (IFR) Reporting Procedures at Uncontrolled Aerodromes	288
9.13	Instruments Flight Rules (IFR) Procedures at an Uncontrolled Aerodrome in Uncontrolled Airspace	289
9.14	Outbound Report	289
9.15	Straight-In Approach	289
9.16	Straight-In Approaches from an Intermediate Fix	289
9.17	Procedure Altitudes and Current Altimeter Setting	290
9.17.1	Corrections for Temperature	290
9.17.2	Remote Altimeter Setting	292
9.18	Departure, Approach and Alternate Minima	292
9.18.1	Category II Instrument Landing System (ILS) Approach Minima	292
9.19	Application of Minima	293
9.19.1	Takeoff Minima	293
9.19.2	Approach Ban	294
9.19.2.1	General Aviation—Non-Precision Approach (NPA), Approach Procedure with Vertical Guidance (APV), CAT I or CAT II Precision Approach	294
9.19.2.2	Approach Ban—General Aviation—CAT III Precision Approach.....	295
9.19.2.3	Approach Ban—Commercial Operators—General—Non-Precision Approach (NPA), Approach Procedure with Vertical Guidance (APV), or CAT I Precision Approach.....	295
9.19.2.4	Approach Ban—Commercial Operators—CAT II and CAT III Precision Approach.....	296
9.19.2.5	Approach Ban—Commercial Operators—Operations Specification—Non-Precision Approach (NPA), Approach Procedure with Vertical Guidance (APV), or CAT I Precision Approach.....	296
9.19.2.6	Runway Visibility	297
9.19.2.7	Localized Phenomenon	297
9.19.2.8	Effects of the High-Intensity Approach Lighting (HIAL) System on <i>Canada Air Pilot</i> (CAP) Advisory Visibility and on Runway Certification	297
9.19.3	Landing Minima	298
9.20	Runway Visual Range (RVR)	299
9.20.1	Definitions	299
9.20.2	Operational Use of Runway Visual Range (RVR)	299

9.21	Aircraft Approach Categories	300
9.22	Straight-In Landing Minima	300
9.23	Circling	301
9.23.1	Standard Circling Approach Radii	301
9.23.2	Expanded Circling Approach Radii	301
9.24	Circling Procedures	302
9.25	Missed Approach Procedure While Visually Manoeuvring in the Vicinity of the Aerodrome	302
9.26	Missed Approach Procedures	302
9.27	Simultaneous Precision Instrument Approaches - Parallel Runways	302
9.28	Simultaneous Precision Instrument Approaches - Converging Runways	303
10.0	Instrument Flight Rules (IFR) — Holding Procedures	303
10.1	General	303
10.2	Holding Clearance	303
10.3	Standard Holding Pattern	304
10.4	Non-Standard Holding Pattern	304
10.5	Entry Procedures	304
10.6	Timing	305
10.7	Speed Limitations	305
10.8	Distance Measuring Equipment (DME) Procedures	305
10.9	Shuttle Procedure	305
10.10	Holding Patterns Published on Enroute and Terminal Charts	306
11.0	Air Traffic Control (ATC) Special Procedures	306
11.1	Adherence to Mach Number	306
11.2	Parallel Offset Procedures	306
11.3	Structured Airspace	306
11.4	Canadian Domestic Routes	306
11.4.1	General	306
11.4.2	North American Route Program (NRP)	306
11.4.2.1	Introduction	306
11.4.2.2	Eligibility	307
11.4.2.3	Procedures	307
11.4.3	Mandatory Instrument Flight Rules (IFR) Routes	307
11.4.4	Fixed Area Navigation (RNAV) Routes	307
11.4.5	Northern Control Area (NCA) Random Routes	307
11.4.6	Arctic Control Area (ACA) Random Routes	307
11.4.7	Polar Routes.....	308
11.4.7.1	General.....	308
11.4.7.2	Flight Planning and Position Reporting.....	308
11.4.7.3	Altitude Assignment.....	308
11.5	North American Route (NAR) System.....	308
11.6	Emergency Security Control of Air Traffic (escat) Plan	308
11.7	Reduced Vertical Separation Minimum (RVSM).....	308
11.7.1	Definitions	308
11.7.2	Reduced Vertical Separation Minimum (RVSM) Airspace	308
11.7.3	Air Traffic Control (ATC) Procedures	309
11.7.4	In-Flight Procedures	309
11.7.5	Flight Planning Requirements	309
11.7.6	Operation of Non-Reduced Vertical Separation Minimum (Non-RVSM) Aircraft in RVSM Airspace.....	309
11.7.7	Delivery Flights for Aircraft that are Reduced Vertical Separation Minimum (RVSM)-Compliant on Delivery	310
11.7.8	Airworthiness and Operational Approval and Monitoring	310
11.7.9	Monitoring	310
11.7.10	North American Approvals Registry and Monitoring Organization (NAARMO)	311
11.7.11	Traffic Alert and Collision Avoidance System (TCAS) II/Airborne Collision Avoidance System (ACAS) II Reduced Vertical Separation Minimum (RVSM) Requirements	311
11.7.12	Mountain Wave Activity (MWA)	311
11.7.13	Wake Turbulence	311
11.7.14	In-Flight Contingencies	312

11.8	Minimum Safe Altitude Warning (MSAW)	313
11.8.1	General.....	313
11.8.2	Procedures.....	314
11.8.3	Pilot-Initiated Terrain Avoidance Procedure.....	314
11.8.4	Air Traffic Control (ATC)-Initiated Terrain Avoidance Procedure.....	314
11.8.5	Assistance to Aircraft in Distress.....	314
11.9	Formation Flights	314
12.0	RAC Annex	315
12.1	General.....	315
12.2	<i>Canadian Aviation Regulations (CARs)</i>	315
12.3	Transportation of Dangerous Goods (TDG) by Air.....	323

RAC—Rules of the Air and Air Traffic Services

1.0 General Information

1.1 Air Traffic Services

The following is a list of control, advisory and information services that are available to pilots.

1.1.1 Air Traffic Control (ATC) and Information Services

The following air traffic control and information services are provided by ACCs and TWRs.

- (a) **Airport control service** is provided by airport TWRs to aircraft and vehicles on the manoeuvring area of an airport and to aircraft operating in the vicinity of an airport.
- (b) **Area control service** is provided by ACCs to IFR and CVFR flights operating within specified control areas.
- (c) **Terminal control service** is provided by ACCs to IFR and CVFR flights operating within specified control areas.
- (d) **Terminal control service** is an additional service provided by IFR units to VFR aircraft operating within Class C airspace.
- (e) **Alerting service** notifies appropriate organizations regarding aircraft in need of search and rescue services, or alerts crash equipment, ambulances, doctors, and any other safety services.
- (f) **Altitude reservation service** provides mission planning support for altitude reservations (ALTRVs) and other military activities, airspace coordination for military or specialized operations in controlled airspace, coordination with user agencies and affected ATS units, and issuing approvals and clearances for aircraft to operate within approved ALTRVs.
- (g) **AMIS** is provided by ACCs for the collection, processing and dissemination of aircraft movement information for use by air defence units relative to flights operating into or within Canadian ADIZ.
- (h) **Flight information service** is provided by ATC units to assist pilots by supplying information concerning known hazardous flight conditions. This information will include data concerning unfavourable flight conditions and other known hazards; which may not have been available to the pilot prior to takeoff or which may have developed along the route of flight.
- (i) **Flight information** will be made available, whenever practicable, to any aircraft in communication with an ATC unit, prior to takeoff or when in flight, except where such service is provided by the aircraft operator. Many factors (such as volume of traffic, controller workload, communications frequency congestion and limitations of ATS surveillance equipment) may prevent a controller from providing this service.

The ATC service has been established primarily for the prevention of collisions and the expediting of traffic. The provision of such service will take precedence over the provision of flight information service, but every effort will be made to provide flight information and assistance.

VFR flights will be provided with information concerning:

- (a) severe weather conditions along the proposed route of flight;
- (b) changes in the serviceability of navigation aids;
- (c) conditions of airports and associated facilities;
- (d) other items considered pertinent to safety of flight.

IFR flights will be provided with information concerning:

- (a) severe weather conditions;
- (b) weather conditions reported or forecast at destination or alternate aerodromes;
- (c) changes in the serviceability of navigation aids;
- (d) condition of airports and associated facilities; and
- (e) other items considered pertinent to the safety of flight.

Flight information messages are intended as information only. If a specific action is suggested, the message will be prefixed by the term “ATC SUGGESTS...” or “SUGGEST YOU...” and the pilot will be informed of the purpose of the suggested action. The pilot is responsible for making the final decision concerning any suggestion.

ATS surveillance equipment is frequently used in the provision of information concerning hazards, such as chaff drops, bird activity and possible traffic conflicts. Due to limitations inherent in all ATS surveillance systems, aircraft, chaff, etc., cannot be detected in all cases.

Whenever practicable, ATC will provide flights with severe weather information pertinent to the area concerned. Pilots may assist ATC by providing pilot reports of severe weather conditions they encounter. ATC will endeavour to suggest alternate routes available in order to avoid areas experiencing severe weather.

ATC will provide pilots intending to operate through chaff areas with all available information relating to proposed or actual chaff drops:

- (a) location of chaff drop area;
- (b) time of drop;
- (c) estimated speed and direction of drift;
- (d) altitudes likely to be affected; and
- (e) relative intensity of chaff.

Information concerning bird activity, obtained through controller's observations or pilot reports, will be provided to aircraft operating in the area concerned. In addition, pilots may be warned of possible bird hazards if ATS surveillance observation indicates the possibility of bird activity. Information will be provided concerning:

- (a) size or species of bird, if known;
- (b) location;
- (c) direction of flight; and
- (d) altitude, if known.

ATS surveillance traffic information and ATS surveillance navigation assistance to VFR flights are contained in RAC 1.5.

1.1.2 Flight Advisory and Information Services

The following flight advisory and information services are provided by FICs and FSSs.

1.1.2.1 Flight Information Centres (FICs)

Pilot briefing service: the provision of, or consultation on, meteorological and aeronautical information to assist pilots in pre-flight planning for the safe and efficient conduct of flight. The flight service specialist adapts meteorological information, including satellite and radar imagery, to fit the needs of flight crew members and operations personnel, and provides consultation and advice on special weather problems. Flight service specialists accept flight plan information during a briefing.

FISE: the exchange on the FISE frequency of information pertinent to the en-route phase of flight. Air traffic information is not provided. Upon request from an aircraft, a FIC provides:

- (a) **meteorological information:** SIGMET, AIRMET, PIREP, aerodrome routine meteorological report (METAR), aviation selected special weather report (SPECI), aerodrome forecast (TAF), altimeter setting, weather radar, lightning information and briefing update;
- (b) **aeronautical information:** NOTAM, RSC, CRFI, MANOT and other information of interest for flight safety; and
- (c) **relay of communications with ATC:** IFR clearance and SVFR authorization.

En-route aircraft may submit to a FIC: PIREPs, IFR and VFR position reports (including arrival and departure times), revised flight plan or flight itinerary information and other reports, such as vital intelligence sightings (CIRVIS) and pollution reports. Fuel dumping information may also be submitted for coordination with the appropriate ACC and for aeronautical broadcast needs.

Aeronautical broadcast service: the broadcast on the FISE frequency, and on 126.7 MHz, of SIGMET, urgent PIREP and information concerning fuel dumping operations.

VFR flight plan alerting service: the notification of RCCs and provision of communications searches when an aircraft on a VFR flight plan or flight itinerary becomes overdue and needs SAR aid.

Flight regularity message service: the relay by FICs of messages between an aircraft in flight and the aircraft operating agency, and vice versa, when an agency with AFTN access subscribes to the service for an annual cost. Agencies interested in subscribing to this service should contact the NAV CANADA Customer Service Centre.

1.1.2.2 Flight Service Stations (FSSs)

AAS: the provision of information pertinent to the arrival and departure phases of flight at uncontrolled aerodromes and for transit through an MF area. AAS is provided on the MF and is normally in conjunction with VCS.

The elements of information listed below are provided, if appropriate, by the flight service specialist during initial aerodrome advisory communications with an aircraft:

- (a) runway;
- (b) wind direction and speed;
- (c) air traffic that warrants attention;
- (d) vehicle traffic;
- (e) wake turbulence cautionary;
- (f) aerodrome conditions;
- (g) weather conditions;
- (h) additional information of interest for the safety of flight.

The flight service specialist updates this information, when appropriate, after the initial advisory. Pilots are encouraged to indicate in initial transmissions to the FSS that information has been obtained from the ATIS or from an AWOS (or LWIS) broadcast, or use the phrase "HAVE NUMBERS" if runway, wind and altimeter information from the previous aerodrome advisory have been received, so that the flight service specialist does not repeat the information.

Mandatory reports by aircraft on the MF are critical for the FSS to be able to provide effective air traffic information. At certain FSS locations, air traffic information may also be based on a situation display. A pilot remains responsible for avoidance of traffic in Class E airspace.

Communications regarding TCAS events and displayed information should be limited to that required to inform the flight service specialist that the aircraft is responding to an RA. Discretion should be used in using the TCAS traffic display to ask questions regarding traffic in the vicinity of an aircraft. As would be expected, aircraft shown on a TCAS display may not match the traffic information provided by the flight service specialist.

NOTAM, RSC and CRFI are included in advisories for a period of 12 hr for domestic traffic, and 24 hr for international traffic, after dissemination by means of telecommunication. Aerodrome conditions published prior to these time limits should have been received in the pilot briefing or can be obtained on request.

Aerodrome lighting is operated by the FSS, unless otherwise indicated in the CFS. The flight service specialist relays ATC clearances, SVFR authorizations, and routinely informs the ACC of all IFR arrival times. The specialist also relays a VFR arrival report to a FIC upon request from an aircraft.

Pilots should be aware that a flight service specialist will alert the appropriate agencies for any aircraft that has received a landing advisory for an aerodrome that lies within an MF area and within radio communication range, if it fails to arrive within 5 min of its latest ETA, and communication cannot be re-established with the aircraft.

VCS: the provision, at locations where AAS is provided, of instructions to control the movements of vehicles, equipment and pedestrians on manoeuvring areas of uncontrolled aerodromes. Flight service specialists will normally instruct vehicle traffic to leave the intended runway at least 5 min prior to the estimated time of landing or before a departing aircraft enters the manoeuvring area. The specialist will coordinate with the pilot prior to authorizing traffic to operate on the intended runway within less than 5 min of the estimated time of landing or the time an aircraft is ready for takeoff.

1.1.2.3 Flight Information Centres (FICs) and Flight Service Stations (FSSs)

RAAS: the provision, via RCO, of information pertinent to the arrival and departure phases of flight and for transit through an MF area.

RAAS consists in the issuance of the same type of information as in AAS, except that it is provided from a remote location. It is emphasized that the flight service specialist cannot observe the runways, taxiways, airspace or weather conditions in the vicinity of the aerodrome. Wind, altimeter and other weather information is usually extracted from the latest METAR or SPECI, and may not always be as representative of actual conditions as in AAS.

VAS: the provision, via RCO, of information and advisories concerning the movements of vehicles, equipment and pedestrians on manoeuvring areas at designated uncontrolled aerodromes. VAS is provided at locations where RAAS is also provided. The flight service specialist will request vehicle traffic to leave the intended runway at least 5 min prior to the estimated time of landing, but cannot ascertain visually if the traffic has actually vacated the runway.

Alerting service: the notification of appropriate organizations regarding aircraft in need of SAR services or alerts of crash equipment, ambulances, doctors and any other safety services. Alerting of a responsible authority, if experiencing unlawful interference, bomb threat or inability to communicate in the clear, is also included in this service.

Emergency assistance service: the provision of aid to a pilot when in an emergency, or potential emergency situation, such as being lost, encountering adverse weather conditions or experiencing aircraft-related emergencies or equipment failure. At some locations, emergency navigational assistance is provided to a pilot who is lost or experiencing IMC, by transferring the pilot to ATC for ATS surveillance service.

NOTAM information service: the collection and dissemination of NOTAM, RSC, and CRFI information by the flight service specialist. A pilot may report to a FIC or to an FSS any hazards to the air navigation system that may need NOTAM distribution. The flight service specialist will distribute the information if it meets the criteria established in the *Canadian NOTAM Operating Procedures* (CNOP).

Weather observation service: the observation, recording and dissemination of surface weather information for aviation purposes.

1.1.2.4 International Flight Service Station (IFSS)

An aeronautical station that provides a communications service for international air operators. Gander is the only IFSS in Canada.

1.1.3 Arctic Territories

Arctic territories are serviced by the Edmonton (Alta.), and Quebec (Que.) FICs, which provide FISE and emergency communication to aircraft operating in the Northwest Territories and Nunavut and in the vicinity of the ADIZ.

1.1.4 Military Flight Advisory Unit (MFAU)

DND operates Military Flight Advisory Unit (MFAU) which provide flight information services that enhance flight safety and efficiency. These services are available by calling the appropriate station followed by "Advisory", i.e. "Namaso Advisory". MFAU provide en route flight information, airport advisory, ground control, field condition reports, flight planning, alerting service, navigation assistance, NOTAM, PIREPs, and weather reports. An MFAU may be used to accept and relay VFR and IFR position reports and ATC clearances.

1.2 Services Other Than Air Traffic Services (ATS)

1.2.1 Universal Communications (UNICOM)

A UNICOM is an air-ground communications facility operated by a private agency to provide PAS service at uncontrolled aerodromes. At these locations the choice of frequencies are 122.7, 122.8, 123.0, 123.3, 123.5, 122.35, 122.95, 123.35, 122.725, 122.775, and 122.825 MHz.

The use of all information received from a UNICOM station is entirely at the discretion of the pilot. The frequencies are published in aeronautical information publications as a service to pilots, but TC takes no responsibility for the use made of a UNICOM frequency.

An AU is an air-ground communications service that can provide approach and landing information to IFR pilots. The service provider is required to ensure that:

- (a) meteorological instruments used to provide the approach and landing information meet the requirements stipulated under CAR 804.01(1)(c) or the applicable exemption; and
- (b) UNICOM operators meet the training requirements stipulated under CAR 804.01(1)(c) or the applicable exemption.

Where the above standards are met, the AU operator may provide a station altimeter setting for an instrument procedure. The wind speed and direction for a straight-in landing from an instrument approach may or may not be provided.

Operators providing AU services may also advise pilots of runway conditions and of vehicle or aircraft positions on the manoeuvring area.

An AU is indicated as “UNICOM (AU)” in the CAP and the CFS.

1.2.2 Airport Radio/Community Aerodrome Radio Station

Airport radio (APRT RDO), in most cases, is provided by a community aerodrome radio station (CARS) and has been established to provide aviation weather and communication services to enhance aircraft access to certain aerodromes.

APRT RDO/CARS service is provided by observer-communicators (O/C) who are trained to conduct aviation weather observations and radio communications to facilitate aircraft arrivals and departures.

Hours of operation are listed in the *Canada Flight Supplement* (CFS) Aerodrome/ Facility Directory under the subheadings COM/ APRT RDO.

Services provided by APRT RDO/CARS include the following:

- (a) **Emergency Service:** The O/C will respond to all emergency calls (distress, urgency and ELT signals), incidents or accidents by alerting a designated NAV CANADA FIC and appropriate local authorities.
- (b) **Communication Service:** The O/C will provide pilots with information in support of aircraft arrivals and departures,

including wind, altimeter, runway and aerodrome status (including vehicle intentions and runway condition), current weather conditions, PIREPs and known aircraft traffic.

NOTES:

1. O/Cs are authorized to provide an altimeter setting for an instrument approach.
2. O/Cs provide limited traffic information. APRT RDOs/ CARS are located at uncontrolled aerodromes within MF areas. Pilots must communicate on the MF as per uncontrolled aerodrome procedures.
3. O/Cs do not provide ATC services. At aerodromes within controlled airspace served by APRT RDO/CARS, pilots must contact ATS via the RCO, PAL or telephone to obtain special VFR authorization or IFR clearances.
- (c) **Weather Observation Service:** The O/C will monitor, observe, record and relay surface weather data for aviation purposes (METARs or SPECIs) in accordance with CAR 804 standards. The O/C may request PIREPs from pilots to confirm weather conditions, such as height of cloud bases.
- (d) **Flight Plan/Flight Information Service:** If necessary, at most APRT RDOs/CARS, O/Cs will accept flight plans/ itineraries; however, pilots are encouraged to obtain a full pre-flight briefing and then file their flight plan/itinerary with a FIC.

NOTE:

Pilots should be aware that O/Cs are only authorized to provide NOTAMs and weather information (METARs or SPECIs) for their own aerodrome. Information for other areas/aerodromes should be obtained from a FIC.

At APRT RDO/CARS sites colocated with an RCO, pilots should open and close flight plans/itineraries, pass position reports and obtain FISE directly from the FIC via the RCO. At sites with no RCO, when requested by the pilot, the APRT RDO/CARS O/C will relay messages to open and close flight plans/ itineraries and position reports (IFR, VFR, DVFR) to a FIC.

- (e) **Monitoring of Equipment/NAVAIDs:** During the APRT RDO/CARS hours of operation, O/Cs will monitor the status of equipment related to aerodrome lighting, weather, communications, etc. Malfunctions will be reported to the designated NAV CANADA facility, and a NOTAM will be issued as required. For site-specific NAVAID monitoring by APRT RDO/CARS, refer to the CFS and Enroute Low Altitude and Enroute High Altitude charts.

1.2.3 Private Advisory Stations (PAS)—Controlled Airports

Aeronautical operators may establish their own private facilities at controlled airports for use in connection with company business, such as servicing of aircraft, availability of fuel, and lodging. The use of PAS at controlled aerodromes shall not include information relative to ATC, weather reports, condition of landing strips, or any other communication normally provided by ATC units.

1.2.4 Apron Advisory Service

Apron advisory service at most controlled airports is provided by ATIS. However, some large airports are providing advisory service on aprons through a separate apron management unit staffed by airport or terminal operator personnel. This service normally includes gate assignment, push-back instructions, and advisories on other aircraft and vehicles on the apron. Aircraft entering the apron will normally be instructed by the ground controller to contact apron prior to or at the designated change-over point. Aircraft leaving the apron shall contact ground on the appropriate frequency to obtain taxi clearance before exiting the apron and before entering the manoeuvring area.

1.3 Automatic Terminal Information Service (ATIS)

ATIS is the continuous broadcasting of recorded information for arriving and departing aircraft on a discrete VHF/UHF frequency. Its purpose is to improve controller and flight service specialist effectiveness and to relieve frequency congestion by automating the repetitive transmission of essential but routine information.

ATIS messages are recorded in a standard format and contain such information as:

- (a) airport name and message code letter;
- (b) weather information, including:
 - (i) time,
 - (ii) surface wind, including gusts,
 - (iii) visibility,
 - (iv) weather and obstructions to vision,
 - (v) ceiling,
 - (vi) sky condition,
 - (vii) temperature,
 - (viii) dew point,
 - (ix) altimeter setting,
 - (x) pertinent SIGMETs, AIRMETs and PIREPs, and
 - (xi) other pertinent remarks;
- (c) type of instrument approach in use, including information on parallel or simultaneous converging runway operations;
- (d) landing runway, both IFR and VFR, including information on hold short operations and the stopping distance available;
- (e) departure runway, both IFR and VFR;
- (f) a NOTAM or an excerpt from a NOTAM, pertinent information regarding the serviceability of a NAVAID, or field conditions applicable to arriving or departing aircraft. These may be deleted from an ATIS message after a broadcast period of 12 hr at domestic airports or 24 hr at international airports;
- (g) instruction that aircraft are to acknowledge receipt of the ATIS broadcast on initial contact with ATC/FSS.

Each recording will be identified by a phonetic alphabet code letter, beginning with ALFA. Succeeding letters will be used for each subsequent message.

Example of an ATIS Message:

*TORONTO INTERNATIONAL INFORMATION
BRAVO. WEATHER AT ONE FOUR ZERO ZERO
ZULU: WIND ZERO FIVE ZERO AT TWO ZERO,
VISIBILITY FIVE HAZE, CEILING THREE
THOUSAND OVERCAST, TEMPERATURE ONE
EIGHT, DEW POINT ONE SIX, ALTIMETER TWO
NINER FOUR SIX, PARALLEL ILS APPROACHES
ARE IN PROGRESS. IFR LANDING ZERO SIX
RIGHT, ZERO SIX LEFT. VFR LANDING ZERO SIX
LEFT. DEPARTURE ZERO SIX LEFT. NOTAM:
GLIDE PATH ILS RUNWAY ONE FIVE OUT OF
SERVICE. INFORM ATC YOU HAVE
INFORMATION BRAVO.*

NOTE:

Current time and RVR measurements will not be included in the ATIS message, but will be issued in accordance with current practices. Temperature and dew point information is derived only from the scheduled hourly weather observations.

Pilots hearing the broadcast should inform the ATC/FSS unit on initial contact that they have received the information, by repeating the code letter that identifies the message, thus obviating the need for the controller/specialist to issue information.

Example:

...WITH BRAVO.

During periods of rapidly changing conditions that would create difficulties in keeping the ATIS message current, the following message will be recorded and broadcasted:

*BECAUSE OF RAPIDLY CHANGING WEATHER/
AIRPORT CONDITIONS, CONTACT ATC/FSS FOR
CURRENT INFORMATION.*

The success and effectiveness of ATIS is largely dependent upon the co-operation and participation of airspace users; therefore, pilots are strongly urged to take full advantage of this service.

1.4 Use of Term “Ceiling and Visibility OK (CAVOK)”

The term “CAVOK” (KAV-OH-KAY) may be used in air-ground communications when transmitting meteorological information to arriving aircraft.

CAVOK refers to the simultaneous occurrence of the following meteorological conditions at an airport:

- (a) no cloud below 5 000 feet, or below the highest minimum sector altitude, whichever is higher, and no cumulonimbus;
- (b) a visibility of 6 SM or more;
- (c) no precipitation, thunderstorms, shallow fog, or low drifting snow.

This term, coupled with other elements of meteorological information, such as wind direction and speed, altimeter setting

and pertinent remarks, will be used in transmissions directed to arriving aircraft and, where applicable, in the composition of ATIS messages. A pilot, on receipt of CAVOK, may request that detailed information be provided.

CAVOK does not apply to the provision of meteorological information to en route aircraft and, therefore, will not be used when such information is transmitted to aircraft engaged in that particular phase of flight.

1.5 ATS Surveillance Service

1.5.1 General

The use of ATS surveillance increases airspace utilization by allowing ATC to reduce the separation interval between aircraft. In addition, ATS surveillance permits an expansion of flight information services, such as ATS surveillance traffic information, ATS surveillance navigation assistance and information on chaff drops and bird activity. Due to limitations inherent in all ATS surveillance systems, it may not always be possible to detect aircraft, weather disturbances, etc. Where ATS surveillance information is derived from secondary surveillance radar (SSR) only (i.e. without associated primary radar coverage), it is not possible to provide traffic information on aircraft that are not transponder-equipped or to provide some of the other flight information (See *AIP Canada* ENR 1.6).

1.5.2 Procedures

Before providing ATS surveillance service, ATC will establish identification of the aircraft concerned either through the use of position reports, identifying turns, or transponders. Pilots will be notified whenever identification is established or lost.

Examples:

IDENTIFIED; or IDENTIFICATION LOST.

Pilots are cautioned that identification of their flight does not relieve them of the responsibility for collision avoidance or terrain (obstacle) clearance. ATC will normally provide identified IFR and CVFR flights with information on observed targets. At locations where an SSR is used without collocated primary radar equipment, ATC cannot provide traffic information on aircraft without a functioning transponder.

ATC assumes responsibility for terrain (obstacle) clearance when vectoring en route IFR and CVFR flights and for IFR aircraft being vectored for arrival until the aircraft resumes normal navigation.

Vectors are used when necessary for separation purposes, when required by noise abatement procedures, when requested by the pilot, or whenever vectors will offer operational advantages to the pilot or the controller. When vectors are initiated, the pilot will be informed of the location to which the aircraft is being vectored.

Example:

*VECTORS TO VICTOR THREE ZERO ZERO,
TURN LEFT HEADING ZERO FIVE ZERO.
VECTORS TO THE VANCOUVER V-O-R ZERO
FIVE THREE RADIAL, FLY HEADING ZERO TWO
ZERO. VECTORS TO FINAL APPROACH
COURSE, DEPART KLEINBURG BEACON ON
HEADING TWO FOUR ZERO.*

Pilots will be informed when vectors are terminated, except when an arriving aircraft is vectored to the final approach course or to the traffic circuit.

Example:

RESUME NORMAL NAVIGATION.

When an aircraft is vectored to final approach or to the traffic circuit, the issuance of approach clearance indicates that normal navigation should be resumed.

Normally ATS surveillance service will be continued until an aircraft leaves the area of surveillance coverage, enters uncontrolled airspace, or is transferred to an ATC unit not equipped with ATS surveillance. When ATS surveillance service is terminated the pilot will be informed accordingly.

Example:

ATS SURVEILLANCE SERVICE TERMINATED.

1.5.3 Air Traffic Service (ATS) Surveillance Traffic Information

Traffic (or workload) permitting, ATC will provide IFR and CVFR flights with information on observed ATS surveillance targets whenever the traffic is likely to be of concern to the pilot, unless the pilot states that the information is not wanted. This information may be provided to VFR aircraft when requested by the pilot, depending on the classification of the airspace (see RAC 2.8).

When issuing ATS surveillance information, ATS units will frequently define the relative location of the traffic, weather areas, etc., by referring to the clock position. In this system, the 12 o'clock position is based on the observed surveillance track rather than the actual nose of the aircraft. In conditions of strong crosswind, this can lead to a discrepancy between the position as reported by the controller and the position as observed by the pilot.

The following diagram illustrates the clock positions.

Figure 1.1—Clock Positions Diagram

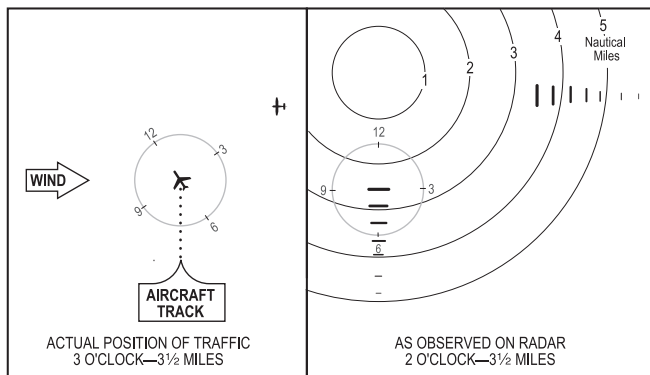

Issue ATS surveillance traffic information to identified aircraft as follows:

- Position of the traffic in relation to the aircraft's observed track.
- Direction of flight.
- Type of aircraft, if known, or the relative speed and the altitude, if known.

NOTE:

Direction of flight may be expressed as OPPOSITE DIRECTION or SAME DIRECTION, while the altitude may be expressed as a number of feet above or below the aircraft receiving the traffic information.

Example:

TRAFFIC, TWO O'CLOCK, THREE AND A HALF MILES, WESTBOUND, B747, ONE THOUSAND FEET ABOVE YOUR ALTITUDE.

Issue ATS surveillance traffic information to non-identified aircraft as follows:

- Position of the traffic in relation to a fix.
- Direction of flight.
- Type of aircraft, if known, or the relative speed and the altitude, if known.

NOTE:

Direction of flight may be expressed as OPPOSITE DIRECTION or SAME DIRECTION, while the altitude may be expressed as a number of feet above or below the aircraft receiving the traffic information.

Example:

TRAFFIC, SEVEN MILES SOUTH OF RESOLUTE BAY VOR, NORTHBOUND, B737, FL300.

1.5.4 ATS Surveillance Navigation Assistance to Visual Flight Rules (VFR) Flights

When requested by pilots, ATS surveillance-equipped ATC units will provide assistance to navigation in the form of position information, vectors or track, and ground speed checks. Flights requesting this assistance must be operating within areas of ATS surveillance and communication coverage, and be identified.

VFR flights may be provided with this service:

- at the request of a pilot, when traffic conditions permit;
- when the controller suggests and the pilot agrees; or
- in the interest of flight safety.

The pilot is responsible for avoiding other traffic and avoiding weather below VFR minima while on a VFR flight on vectors.

If a vector will lead a VFR flight into IFR weather conditions, the pilot must inform the controller and take the following action:

- if practicable, obtain a vector which will allow the flight to remain in VFR weather conditions; or
- if an alternative vector is not practicable, revert to navigation without assistance; or
- if the pilot has an IFR rating and the aircraft is equipped for IFR flight, the pilot may file an IFR flight plan, and request an IFR clearance.

Emergency ATS surveillance assistance will be given to VFR flights which are able to maintain two-way radio communication with the unit, are within coverage, and can be identified.

Pilots requiring ATS surveillance assistance during emergency conditions should contact the nearest ATC unit and provide the following information:

- Declaration of emergency (state nature of difficulty and type of assistance required).
- Position of aircraft and weather conditions within which the flight is operating.
- Type of aircraft, altitude, and whether equipped for IFR flight.
- Whether pilot has an IFR Rating.

Pilots unable to contact ATS surveillance but in need of emergency assistance may alert ATS surveillance by flying a triangular pattern.

1.5.5 Obstacle Clearance During Vectors

- IFR Flights:** The pilot of an IFR flight is responsible for ensuring that the aircraft is operated with adequate clearance from obstacles and terrain; however, when the flight is being vectored, ATC will ensure that the appropriate obstacle clearance is provided.

Minimum vectoring altitudes (lowest altitude at which an aircraft may be vectored and still meet obstacle clearance criteria), which may be lower than minimum altitudes shown on navigation and approach charts, have been established

at a number of locations to facilitate transitions to instrument approach aids. When an IFR flight is cleared to descend to the lower altitude, ATC will provide terrain and obstacle clearance until the aircraft is in a position from which an approved instrument approach or a visual approach can be commenced.

If a communication failure occurs while a flight is being vectored at an altitude below the minimum IFR altitudes shown in the instrument approach chart, the pilot should climb immediately to the appropriate published minimum altitude, unless the flight is able to continue in Visual Meteorological Conditions (VMC).

- (b) **VFR Flights:** The pilot of a VFR aircraft remains responsible for maintaining adequate clearance from obstacles and terrain when the flight is being vectored by ATC.

If adequate obstacle or terrain clearance cannot be maintained on a vector, the pilot must inform the controller and take the following action:

- (i) if practicable, obtain a heading that will enable adequate clearance to be maintained, or climb to a suitable altitude, or
- (ii) revert to navigation without ATS surveillance assistance.

1.5.6 Misuse of Vectors

Pilots have, on occasion, for practice purposes, followed ATS surveillance instructions issued to other pilots without realizing the potential hazard that accompanies such action.

ATC may require aircraft to make turns for identification; however, when more than one aircraft target is observed making a turn, identification becomes difficult or impossible. Should misidentification be the result of more than one aircraft following the instructions issued by ATC, it could be hazardous to the aircraft involved.

Any pilot wishing to obtain ATS surveillance practice, however, needs only to contact the appropriate ACC or TCU and request practice vectors. Practice vectors will be issued to the extent that air traffic conditions permit.

1.5.7 Canadian Forces Radar Assistance

The Canadian Forces can provide assistance in an emergency to civil aircraft operating within the ADIZ.

No responsibility for the direct control of aircraft is accepted and radar assistance does not absolve the captain of the responsibility of complying with ATC clearances or other required procedures. Assistance consists of:

- (a) track and ground speed checks—speeds in kt;
- (b) position of the aircraft in geographic reference, or by bearing and distance from the station—distances are in NM and bearings in degrees True; and
- (c) position of heavy cloud in relation to the aircraft.

To obtain assistance in the North Warning System area, call “Radar Assistance” on 126.7 MHz; or when circumstances require a MAYDAY call, use 121.5 MHz, giving all the necessary details. When assistance is required in ADIZ areas contact will have to be made on the 121.5 MHz frequency or on the UHF frequencies 243.0 or 364.2 MHz. Initial contact should be made at the highest practicable altitude. If air defence commitments preclude the granting of radar assistance, the ground station will transmit the word “UNABLE” and no further explanation will be given.

1.5.8 The Use of ATS Surveillance in the Provision of Aerodrome Advisory Service (AAS) and Remote Aerodrome Advisory Service (RAAS) by Flight Service Stations (FSS)

Certain FSSs are equipped with an ATS surveillance display to aid the flight service specialist in monitoring the aircraft traffic situation and to enhance the accuracy of traffic information provided in AAS or RAAS.

An FSS equipped with an ATS surveillance display:

- (a) may instruct an aircraft to “SQUAWK IDENT” or assign a specific SSR code to the aircraft;
- (b) will acknowledge the squawk transmission or SSR code change by stating the phrase “ROGER IDENT”;
- (c) will issue the reminder “NO CONTROL SERVICE AVAILABLE, THIS IS AN ADVISORY SERVICE,” if deemed appropriate;
- (d) may issue observed ATS surveillance traffic information with reference to the 12-hr clock position or geographical locations.

It is important for pilots to keep in mind that:

- (a) flight service specialists may stop monitoring the ATS surveillance display at any time without prior notice to aircraft;
- (b) FSSs do not inform aircraft when identification is lost;
- (c) FSSs do not provide control services such as vectors and conflict resolution;
- (d) pilots are responsible for maintaining a visual lookout outside the cockpit at all times for the purpose of avoiding a collision with other aircraft, terrain and obstacles.

1.6 Air Traffic Control (ATC) Clearances, Instructions and Information

Whenever pilots receive and accept an ATC clearance, they shall comply with the clearance. If unable to comply with the clearance, pilots should immediately inform ATC since the controller will understand the acknowledgement of the clearance as indicating acceptance. For example, upon receiving a clearance for takeoff, pilots should acknowledge the clearance and take off without undue delay or, if not ready to take off at that particular time, inform ATC of their intentions, in which case the clearance may be changed or cancelled.

A clearance will be identified by the use of some form of the word “clear” in its contents. An instruction will always be worded in such a manner as to be readily identified, although the word “instruct” will seldom be included. Pilots shall comply with and acknowledge receipt of all ATC instructions directed to and received by them, provided the safety of the aircraft is not jeopardized (CAR 602.31).

CAR 602.31 permits pilots to deviate from an ATC instruction or clearance in order to follow TCAS or ACAS RAs. Pilots responding to an RA shall advise the appropriate ATC unit of the deviation as soon as possible and shall expeditiously return to the last ATC clearance received and accepted, or the last ATC instruction received and acknowledged prior to the RA manoeuvre. Aircraft manoeuvres conducted during an RA should be kept to the minimum necessary to satisfy the resolution advisory. For more information on TCAS and ACAS, see the COM chapter.

ATC is not responsible for the provision of IFR separation to an IFR aircraft which carries out a TCAS or ACAS RA manoeuvre until one of the following conditions exist:

- (a) the aircraft has returned to the last ATC clearance received and accepted, or last ATC instruction received and acknowledged prior to the RA; or
- (b) an alternate ATC clearance or instruction has been issued.

TCAS and ACAS do not alter or diminish the pilot-in-command’s responsibility to ensure safe flight. Since TCAS and ACAS do not respond to aircraft which are not transponder-equipped or to aircraft with a transponder failure, TCAS and ACAS alone do not ensure safe operation in every case. The services provided by ATC units are not predicated upon the availability of TCAS or ACAS equipment in an aircraft.

It should be remembered that air traffic control is predicated on known air traffic only and, when complying with clearances or instructions, pilots are not relieved of the responsibility of practicing good airmanship.

NOTE:

A clearance or instruction is only valid while in controlled airspace. Pilots crossing between controlled and uncontrolled airspace should pay close attention to the terrain and obstacle clearance requirements.

ATS personnel routinely inform pilots of conditions, observed by others or by themselves, which may affect flight safety and are beyond their control. Examples of such conditions are observed airframe icing and bird activity. These are meant solely as assistance or reminders to pilots and are not intended in any way to absolve the pilot of the responsibility for the safety of the flight.

1.6.1 Inability to Issue Clearance

ATC clearances are based on known traffic conditions and aerodrome limitations which affect the safety of aircraft operations. This encompasses aircraft in flight and on the manoeuvring area, vehicles, and other potential obstructions. ATC is not authorized to issue ATC clearances when traffic conditions are unknown, when any part of the aerodrome is partially or fully closed, or when the aerodrome or runway operating minima are not met.

There are two distinct phrases used when unable to issue ATC clearances:

- (a) **AT YOUR DISCRETION**—Used to approve aircraft movement on any surface not visible from the control tower due to a physical obstruction other than weather phenomena, or on the non-manoevring area. Pilots are responsible for manoeuvring safely with respect to traffic or hazards encountered during the operation. ATC will provide information on known traffic or obstructions when possible.
- (b) **UNABLE TO ISSUE CLEARANCE**—Used when controllers are not authorized to issue an ATC clearance. Pilots who continue without a clearance in these circumstances may be subject to regulatory action by TC. ATC will provide pertinent taxi, take-off or landing information and then file an aviation occurrence report. Pilots are responsible for manoeuvring safely with respect to traffic or other hazards encountered during the operation.

1.6.1.1 Examples

The following are scenarios in which ATC may not be able to provide a clearance, followed by ensuing ATC actions, and examples of phraseology that will be used.

- (a) **ATIS message**—ATC will include the following information in an ATIS message, as applicable, upon restriction or suspension of landings or takeoffs. These restrictions or suspensions may be due to the implementation of RVOP or LVOP, direction from the airport operator, obstructed runway protected area, or other reasons.

NOTE:

When conditions are rapidly changing, this information may be issued by ATC, rather than via the ATIS.

Examples:

*LOW VISIBILITY PROCEDURES IN EFFECT.
RUNWAY ZERO FOUR NOT AUTHORIZED FOR
LANDING.*

*REDUCED VISIBILITY PROCEDURES IN EFFECT.
RUNWAY TWO TWO NOT AVAILABLE.*

*RUNWAY ONE THREE NOT AVAILABLE DUE TO
RUNWAY PROTECTED AREA OBSTRUCTION.*

(b) Operations on a surface other than a runway

- (i) If the pilot of a fixed-wing aircraft requests landing or takeoff from a surface other than a runway or area approved and designated for that purpose, ATC will provide traffic and obstruction information; control instructions, if necessary; and inform the pilot that landing or takeoff will be at the pilot's discretion.

NOTE:

Examples of surfaces other than a runway may include areas at or adjacent to the airport, areas in the control zone but not at the airport, a water aerodrome, or a temporary landing area in the control zone.

Example:

GOLF JULIETT ALFA LIMA, WIND THREE ZERO ZERO AT FIFTEEN, TAKE OFF AT YOUR DISCRETION.

- (ii) Workload permitting, ATC will provide traffic and obstruction information to aircraft taxiing on a non-maneuvring area.

Example:

GOLF LIMA BRAVO JULIETT, TAXI AT YOUR DISCRETION.

- (iii) If necessary, ATC will inform a taxiing aircraft that a portion of the manoeuvring area is not visible from the tower and, if possible, provide traffic and obstruction information.

NOTE:

Restricted visibility of the manoeuvring area may be the result of a structure, but excludes situations due to weather.

Example:

FOXTROT ALFA BRAVO CHARLIE, TAXIWAY NOT VISIBLE, TAXI AT YOUR DISCRETION ON TAXIWAY ALFA.

- (c) **RVOP and LVOP**—The following procedures will be used by ATC when implementation of RVOP or LVOP results in manoeuvring area restrictions or closures. RVOP and LVOP procedures vary across Canada, depending on airport operating limits.

- (i) If a pilot requests taxi clearance, ATC will inform the pilot that taxi clearance cannot be issued, and provide the reason. Pilots shall make the request prior to commencing push-back with the intent of taking off; commencing push-back with the intent of taxiing to the de-icing bay; or commencing taxiing on the manoeuvring area under the aircraft's own power with the intent of taking off.

Example:

FOXTROT BRAVO WHISKY DELTA, UNABLE TAXI CLEARANCE ON TAXIWAY CHARLIE, LOW VISIBILITY PROCEDURES IN EFFECT.

- (ii) If a pilot is taxiing for takeoff, ATC will inform the pilot that clearance cannot be issued on the intended runway; provide the reason; determine if another runway is available for takeoff; inform the pilot of the alternate runway; and request the pilot's intentions.

Example:

GOLF JULIETT ALFA LIMA, UNABLE CLEARANCE. REDUCED VISIBILITY PROCEDURES IN EFFECT. RUNWAY THREE TWO CLOSED.

Then, if appropriate:

GOLF JULIETT ALFA LIMA, RUNWAY TWO FIVE AVAILABLE, ADVISE INTENTIONS.

NOTE:

If no alternate runway is available ATC will request the pilot's intentions.

Example:

FOXTROT ALFA BRAVO CHARLIE, UNABLE CLEARANCE. LOW VISIBILITY PROCEDURES IN EFFECT. ALL RUNWAYS CLOSED. ADVISE INTENTIONS.

- (iii) If a pilot requests taxi after landing, ATC will provide taxi clearance.

Example:

FOXTROT BRAVO WHISKY DELTA, TAXI VIA ECHO.

- (iv) If a pilot requests landing or takeoff, ATC will inform the pilot that a clearance cannot be issued; provide the reason; and request the pilot's intentions.

Example:

GOLF JULIETT ALFA LIMA, UNABLE CLEARANCE RUNWAY ONE EIGHT, LANDING NOT AUTHORIZED. ADVISE INTENTIONS.

- (v) If the pilot chooses to land or take off anyway, and traffic permits, ATC will acknowledge the pilot's intentions; provide landing or take-off information as well as any special information required; notify the airport operator; and complete an aviation occurrence report.

NOTE:

Special information may include traffic, hazards, obstructions, runway exits, runway surface conditions, or other pertinent information.

Example:

GOLF LIMA BRAVO JULIETT, ROGER.

(d) **Denial of clearance**—The following procedures will be used when ATC refuses a clearance request because the airport or part of the airport is closed by the operator; or ATC is directed to deny taxi clearance by NAV CANADA or other authority.

- (i) If the pilot requests a landing, takeoff or other manoeuvre, ATC will inform the pilot that a clearance cannot be issued; provide the reason; provide pertinent NOTAM(s) or airport condition directive(s); and request the pilot's intentions.

Example:

WESTJET THREE SEVEN ONE, UNABLE CLEARANCE. RUNWAY ZERO SEVEN IS CLOSED FOR MAINTENANCE

UNTIL ONE NINE ZERO ZERO ZULU AS PER NOTAM. ADVISE INTENTIONS.

- (ii) If the pilot chooses to land, take off or manoeuvre anyway, and traffic permits, ATC will acknowledge the pilot's intentions; provide landing, take-off or manoeuvring information as well as any special information required; notify the airport operator; and complete an aviation occurrence report.

NOTE:

Special information may include traffic, hazards, obstructions, runway exit, runway surface conditions, or other pertinent information.

Example:

AIR CANADA THREE FIVE SIX, ROGER.

(e) **Taxi authorization**—If a pilot requests a push-back from a loading position on the apron, ATC will inform the pilot that the push-back is at pilot's discretion and provide traffic information, if possible.

Example:

NOVEMBER ONE THREE SIX TWO ALFA, PUSH BACK AT YOUR DISCRETION.

(f) **Helicopters**—If a helicopter pilot intends to land or take off from a non-manoeuving area approved for that purpose, ATC will provide traffic and obstruction information; control instructions, if necessary; and inform the pilot that landing or takeoff will be at the pilot's discretion.

Example:

GOLF JULIETT ALFA DELTA, TRAFFIC CHEROKEE DEPARTING RUNWAY THREE ONE, WIND THREE ZERO ZERO AT TEN. TAKE OFF AT YOUR DISCRETION FROM APRON FOUR.

(g) **Taxiing aircraft and ground traffic**—The following procedures will be used when ATC is unable to determine that the runway or runway protected area is or will be free of obstacles before either an arrival crosses the threshold or a departure starts its take-off roll.

NOTE:

Obstacles include taxiing aircraft and ground traffic.

- (i) If the pilot requests a landing or takeoff, ATC will inform the pilot that a clearance cannot be issued; provide the reason; and request the pilot's intentions.

Example:

GOLF ZULU YANKEY ZULU, UNABLE LANDING CLEARANCE RUNWAY ONE FOUR, VEHICLE INSIDE THE RUNWAY PROTECTED AREA AT ALFA. ADVISE INTENTIONS.

- (ii) If the pilot chooses to land or take off anyway, and traffic permits, ATC will acknowledge the pilot's intentions; provide landing or take-off information as well as any special information required; notify the airport operator; and complete an aviation occurrence report.

NOTE:

Special information may include traffic, hazards, obstructions, runway exit, runway surface conditions or other pertinent information.

Example:

JAZZ SIX EIGHT EIGHT, ROGER.

- (iii) If a landing or take-off clearance has been issued and ATC is unable to determine that the runway or runway protected area is or will be free of obstacles before an arrival crosses the threshold, or a departure starts its take-off roll, ATC will cancel the clearance.

NOTE:

Controllers will use their best judgement if cancelling the clearance may result in a hazardous situation.

Example:

GOLF ALFA DELTA ALFA, TAKE-OFF CLEARANCE CANCELLED, AIRCRAFT INSIDE THE RUNWAY PROTECTED AREA AT CHARLIE, ADVISE INTENTIONS.

1.7 Air Traffic Control (ATC) Service Priority

1.7.1 Normal Conditions

Normally, ATC provides control service on a first-come, first-served basis. However, controllers may adjust the arrival or departure sequence in order to facilitate the maximum number of aircraft movements with the least average delay. Altitude assignment may also be adjusted in order to accommodate the maximum number of aircraft at their preferred altitudes, or to comply with ATFM requirements.

1.7.2 Special Conditions

Flight priority is provided to:

- (a) an aircraft that is known or believed to be in a state of emergency;

NOTE:

This category includes aircraft subjected to unlawful interference or other distress or urgency conditions that may compel the aircraft to land or require flight priority.

- (b) a MEDEVAC flight;
- (c) military or civilian aircraft participating in SAR missions and identified by the radiotelephony call sign “RESCUE” and the designator “RSCU,” followed by an appropriate flight number;
- (d) military aircraft that are departing on:
 - (i) operational air defence flights,
 - (ii) planned and coordinated air defence training exercises, and
 - (iii) exercises to an altitude reservation; or
- (e) an aircraft carrying His Majesty the King, the Governor General, the Prime Minister, heads of state, or foreign heads of government.

1.7.3 Minimum Fuel Advisory

Pilots may experience situations where traffic, weather or other delays result in concern about the aircraft’s fuel state. The term MINIMUM FUEL describes a situation where the aircraft’s fuel supply has reached a state where the flight is committed to land at a specific aerodrome and no additional delay can be accepted. The pilot should advise ATC as soon as possible that a MINIMUM FUEL condition exists. This is not an emergency situation, but merely an advisory that indicates an emergency is possible should any undue delay occur.

A minimum fuel advisory does not imply an ATC traffic priority; however, ATC special flight handling procedures are as follows:

- (a) Be alert for any occurrence or situation that might delay the aircraft;
- (b) Respond to the declaration and keep the pilot informed of any anticipated delay as soon as you become aware, using the following phraseology:
*ROGER or
ROGER NO DELAY EXPECTED or
ROGER EXPECT (delay information).*
- (c) Inform the next sector or unit of the minimum fuel status of the aircraft and
- (d) Record the information in the unit log, reduce unnecessary radio transmissions and ensure appropriate responses; use of internationally recognized fuel-related phraseology among pilots and controllers is essential.

Traffic priority is given to a pilot who declares an emergency for fuel by broadcasting MAYDAY MAYDAY MAYDAY FUEL. Use of standardized pilot phraseology distinguishes minimum fuel from a fuel emergency, assuring pilot intent without further verification

1.8 Collision Avoidance—Right of Way (Canadian Aviation Regulations [CARs])

Reckless or Negligent Operation of Aircraft

602.01

No person shall operate an aircraft in such a reckless or negligent manner as to endanger or be likely to endanger the life or property of any person.

Right-of-Way – General

602.19

- (1) Notwithstanding any other provision of this section,
 - (a) the pilot-in-command of an aircraft that has the right-of-way shall, if there is any risk of collision, take such action as is necessary to avoid collision; and
 - (b) where the pilot-in-command of an aircraft is aware that another aircraft is in an emergency situation, the pilot-in-command shall give way to that other aircraft.
- (2) When two aircraft are converging at approximately the same altitude, the pilot-in-command of the aircraft that has the other on its right shall give way, except as follows:
 - (a) a power-driven, heavier-than-air aircraft shall give way to airships, gliders and balloons;
 - (b) an airship shall give way to gliders and balloons;
 - (c) a glider shall give way to balloons; and
 - (d) a power-driven aircraft shall give way to aircraft that are seen to be towing gliders or other objects or carrying a slung load.

- (3) When two balloons operating at different altitudes are converging, the pilot-in-command of the balloon at the higher altitude shall give way to the balloon at the lower altitude.
- (4) Where an aircraft is required to give way to another aircraft, the pilot-in-command of the first-mentioned aircraft shall not pass over or under, or cross ahead of, the other aircraft unless passing or crossing at such a distance as will not create any risk of collision.
- (5) Where two aircraft are approaching head-on or approximately so and there is a risk of collision, the pilot-in-command of each aircraft shall alter its heading to the right.
- (6) An aircraft that is being overtaken has the right-of-way and the pilot-in-command of the overtaking aircraft, whether climbing, descending or in level flight, shall give way to the other aircraft by altering the heading of the overtaking aircraft to the right, and no subsequent change in the relative positions of the two aircraft shall absolve the pilot-in-command of the overtaking aircraft from this obligation until that aircraft has entirely passed and is clear of the other aircraft.
- (7) Where an aircraft is in flight or manoeuvring on the surface, the pilot-in-command of the aircraft shall give way to an aircraft that is landing or about to land.
- (8) The pilot-in-command of an aircraft that is approaching an aerodrome for the purpose of landing shall give way to any aircraft at a lower altitude that is also approaching the aerodrome for the purpose of landing.
- (9) The pilot-in-command of an aircraft at a lower altitude, as described in subsection (8), shall not overtake or cut in front of an aircraft at a higher altitude that is in the final stages of an approach to land.
- (10) No person shall conduct or attempt to conduct a takeoff or landing in an aircraft until there is no apparent risk of collision with any aircraft, person, vessel, vehicle or structure in the takeoff or landing path.

Right-of-Way – Aircraft Manoeuvring on Water

602.20

- (1) Where an aircraft on the water has another aircraft or a vessel on its right, the pilot-in-command of the first-mentioned aircraft shall give way.
- (2) Where an aircraft on the water is approaching another aircraft or a vessel head-on, or approximately so, the pilot-in-command of the first-mentioned aircraft shall alter its heading to the right.
- (3) The pilot-in-command of an aircraft that is overtaking another aircraft or a vessel on the water shall alter its heading to keep well clear of the other aircraft or the vessel.

Avoidance of Collision

602.21

No person shall operate an aircraft in such proximity to another aircraft as to create a risk of collision.

Formation Flight

602.24

No person shall operate an aircraft in formation with other aircraft except by pre-arrangement between.

- (a) the pilots-in-command of the aircraft; or
- (b) where the flight is conducted within a control zone, the pilots-in-command and the appropriate air traffic control unit.

1.9 Aerobatic Flight (*Canadian Aviation Regulations [CARs] 602.27 and 602.28*)

Aerobatic Manoeuvres – Prohibited Areas and Flight conditions

602.27

No person operating an aircraft shall conduct aerobatic manoeuvres

- (a) over a built-up area or an open-air assembly of persons;
- (b) [Repealed, SOR/2019-119, s. 28]
- (c) when flight visibility is less than three miles;
- (d) below 2,000 ft AGL, except in accordance with a special flight operations certificate issued pursuant to section 603.02 or 603.67;
- (e) in any class of airspace that requires radio contact with air traffic services unless the appropriate unit that provides air traffic services is advised that aerobatic manoeuvres will be conducted; or
- (f) in Class A, B or C airspace or Class D Control Zones without prior co-ordination between the pilot-in-command and the air traffic control unit that provides air traffic control service in that airspace.

Aerobatic Manoeuvres with Passengers

602.28

No person operating an aircraft with a passenger on board shall conduct aerobatic manoeuvres unless the pilot-in-command of the aircraft has engaged in

- (a) at least 10 hours dual flight instruction in the conducting of aerobatic manoeuvres or 20 hours conducting aerobatic manoeuvres; and
- (b) at least one hour of conducting aerobatic manoeuvres in the preceding six months.

1.10 Conservation

1.10.1 Fur and Poultry Farms

Experience has shown that aviation noise caused by rotary wing and fixed wing aircraft flying at low altitudes can cause serious economic losses to the farming industry. The classes of livestock particularly sensitive are poultry (including ostriches and emus), because of the crowding syndrome and stampeding behaviour they exhibit when irritated and frightened, and foxes who, when excited, will eat or abandon their young. Avoid overflying these farms below 2 000 ft AGL.

Fur farms may be marked with chrome yellow and black stripes painted on pylons or roofs. In addition, a red flag may be flown during whelping season (February–May).

Pilots are therefore warned that any locations so marked should be avoided, and special vigilance should be maintained during the months of February, March, April and May.

1.10.2 Protection of Wildlife

It is vital that all pilots understand the importance of wildlife conservation. They are urged to become familiar with the game laws in force in the various provinces and territories, and encouraged to co-operate with all game officers to ensure that violations of game laws do not occur. The *Migratory Birds Regulations* prohibit the intentional killing of migratory birds through the use of an aircraft.

Pilots should be aware that flying low over herds of wild animals such as reindeer, caribou, moose or muskoxen may result in reducing the animal population. Accidents resulting in broken bones may increase. Exhausted and disorganized animals are more susceptible to be attacked by wolves. Feeding is interrupted, and normal herd movement and reproductive functions may be seriously disrupted.

Serious damage can also be done to migratory birds by low-flying aircraft. Geese in particular have a great fear of aircraft, and their movements may be seriously disorganized by such interference. As well, many bird species in Canada are in decline, and it is felt that every effort should be made to protect them.

In the interest of conserving wildlife, pilots must not fly at an altitude of less than 2 000 ft AGL when in the vicinity of herds of wildlife animals or above wildlife refuges/bird sanctuaries, depicted on affected aeronautical charts.

The landing or takeoff of aircraft in areas designated as bird sanctuaries may require a permit. Contact information for bird sanctuaries can be found at Environment and Climate Change Canada's Web site: <<https://www.canada.ca/en/environment-climate-change/services/migratory-bird-sanctuaries.html>>.

Contact information for provincial and territorial game officers and information concerning the preservation of wildlife within the various provinces and territories in Canada can be found in the *AIP Canada* on the NAV CANADA Web site at: <<https://www.navcanada.ca/en/aeronautical-information/aip-canada.aspx>>.

Information pertaining to the *Migratory Birds Regulations* may be obtained at <https://laws-lois.justice.gc.ca/eng/regulations/SOR-2022-105/index.html> or by contacting:

Assistant Deputy Minister
Canadian Wildlife Service
Environment and Climate Change Canada
Ottawa ON K1A 0H3

Tel.: 1-800-668-6767

E-mail: ec.enviroinfo.ec@canada.ca

1.10.3 National, Provincial and Municipal Parks, Reserves and Refuges

To preserve the natural environment of parks, reserves and refuges, and to minimize the disturbance to the natural habitat, overflights should not be conducted below 2 000 ft AGL. To assist pilots in observing this, boundaries are depicted on the affected aeronautical charts.

The landing or takeoff of aircraft in national parks and national park reserves may only take place at prescribed locations. Contact information for each location can be found on the Parks Canada Web site at: <www.pc.gc.ca/>.

Additional details can be found in the *National Parks of Canada Aircraft Access Regulations* available at: <<http://laws-lois.justice.gc.ca/eng/regulations/SOR-97-150/page-1.html>>.

2.0 Airspace – Requirements and Procedures

2.1 General

Canadian airspace is divided into a number of categories, which in turn are subdivided into a number of areas and zones. The various rules are simplified by the classification of all Canadian airspace. This section describes all of the above in detail, as well as the regulations and procedures specific to each. The official designation of all airspace is published in the DAH. Canadian airspace is managed by NAV CANADA in accordance with the terms established for the transfer of the air navigation system (ANS) from government operation to NAV CANADA, and with the rights granted to the corporation pursuant to the *Civil Air Navigation Services Commercialization Act*.

2.2 Canadian Domestic Airspace (CDA)

Canadian Domestic Airspace (CDA) includes all airspace over the Canadian land mass, the Canadian Arctic, Canadian Archipelago and those areas of the high seas within the airspace boundaries. These boundaries are depicted on the Enroute Charts.

2.2.1 Northern and Southern Domestic Airspace

CDA is geographically divided into the SDA and the NDA, as indicated in Figure 2.1. In the SDA, magnetic track is used to determine cruising altitude or flight level for direction of flight.

In the NDA, runway heading is given in degrees true, and true track is used to determine cruising altitude or flight level for direction of flight in lieu of magnetic track. This is due to the diminishing horizontal component of the earth’s magnetic field in proximity to the magnetic North Pole and its effects on magnetic compass systems.

Figure 2.1—Boundaries of Canadian Domestic Airspace, Northern Domestic Airspace and Southern Domestic Airspace

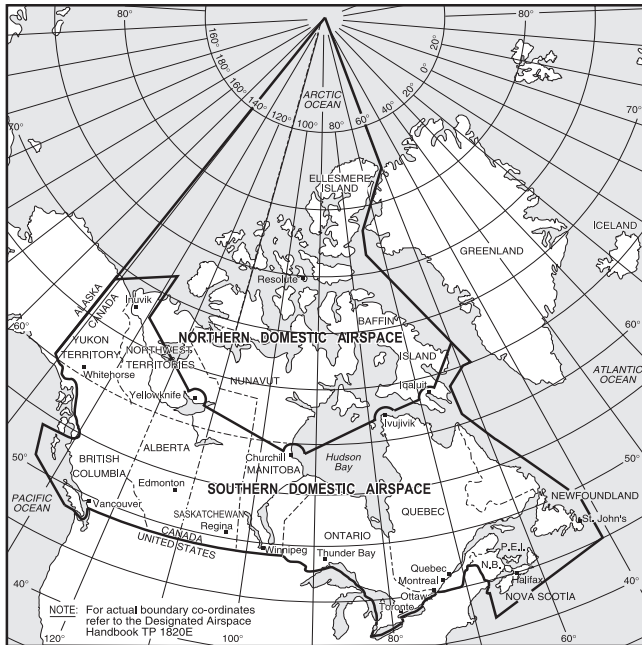

2.3 High- and Low-Level Airspace

The CDA is further divided vertically into low-level airspace, which consists of all of the airspace below 18 000 ft ASL; and high-level airspace which consists of all airspace from 18 000 ft ASL and above.

2.3.1 Cruising Altitudes and Flight Levels Appropriate to Aircraft Track

General Provisions

- (a) The appropriate altitude or flight level for aircraft in level cruising flight is determined in accordance with:
 - (i) the magnetic track, in SDA; and
 - (ii) the true track, in NDA.
- (b) When an aircraft is operated in level cruising flight:
 - (i) at more than 3 000 ft AGL, in accordance with VFR;
 - (ii) in accordance with IFR; or
 - (iii) during a CVFR flight;

The pilot-in-command of an aircraft shall ensure that the aircraft is operated at an altitude or flight level appropriate to the track, unless he/she is assigned an altitude or flight level by an ATC unit or by written authority from the Minister.

- (c) RVSM cruising flight levels appropriate to aircraft track are applicable in designated RVSM airspace.
- (d) The pilot-in-command of an aircraft operating within controlled airspace between 18 000 ft ASL and FL 600, inclusive, shall ensure that the aircraft is operated in accordance with IFR unless otherwise authorized in writing by the Minister. (CAR 602.34).

NOTE:

As per the table in CAR 602.34(2), a vertical separation of 2 000 ft is required from FL 290 to FL 410 inclusive.

Table 2.1—Aircraft Tracks at Various Altitudes and Flight Levels

ALTITUDES OR FLIGHT LEVELS	AIRCRAFT TRACK	
	000° - 179°	180° - 359°
ABOVE FLIGHT LEVEL 290: FLY 4 000 FT INTERVALS	BEGINNING AT FLIGHT LEVEL 290 (FL 290, 330, 370, 410, 450)	BEGINNING AT FLIGHT LEVEL 310 (FL 310, 350, 390, 430, 470)
RVSM	FL 290, 310, 330, 350, 370, 390, 410	FL 300, 320, 340, 360, 380, 400
AT OR ABOVE 18 000 ASL BUT BELOW FL 290: FLY 2 000 FT INTERVALS	ODD FLIGHT LEVELS (FL 190, 210, 230, etc.)	EVEN FLIGHT LEVELS (FL 180, 200, 220, etc.)
BELOW 18 000 ASL: (FLY CORRESPONDING FLIGHT LEVELS IN STANDARD PRESSURE REGION) FLY 2 000 FT INTERVALS	IFR and CVFR	IFR and CVFR
	ODD THOUSANDS ASL (1 000, 3 000, 5 000, etc.)	EVEN THOUSANDS ASL (2 000, 4 000, 6 000, etc.)
	VFR	VFR
	ODD THOUSANDS plus 500 FT ASL (3 500, 5 500, 7 500, etc.)	EVEN THOUSANDS plus 500 FT ASL (4 500, 6 500, 8 500, etc.)

2.4 Flight Information Regions (FIRs)

A Flight Information Region (FIR) is an airspace of defined dimensions extending upwards from the surface of the earth, within which flight information service and alerting services are provided. The Canadian Domestic Airspace is divided into the Vancouver, Edmonton, Winnipeg, Toronto, Montréal, Moncton and Gander Domestic Flight Information Regions. Gander Oceanic is an additional FIR allocated to Canada by ICAO for the provision of flight information and alerting services over the high seas.

Canadian Flight Information Regions are described in the *Designated Airspace Handbook* (TP 1820E), and are depicted on the Enroute Charts and illustrated in Figure 2.2.

Agreements have been effected between Canada and the United States to permit reciprocal air traffic control services



outside of the designate national FIR boundaries. An example is V300 and J500 between SSM and YQT. The control of aircraft in US airspace delegated to a Canadian ATC unit is effected by applying the Canadian rules, procedures and separation minima with the following exceptions:

- (a) aircraft will not be cleared to maintain “1 000 feet on top”;
- (b) ATC vertical separation will not be discontinued on the basis of visual reports from the aircraft; and
- (c) Canadian protected airspace criteria for track separation will not be used.

Figure 2.2—Flight Information Regions

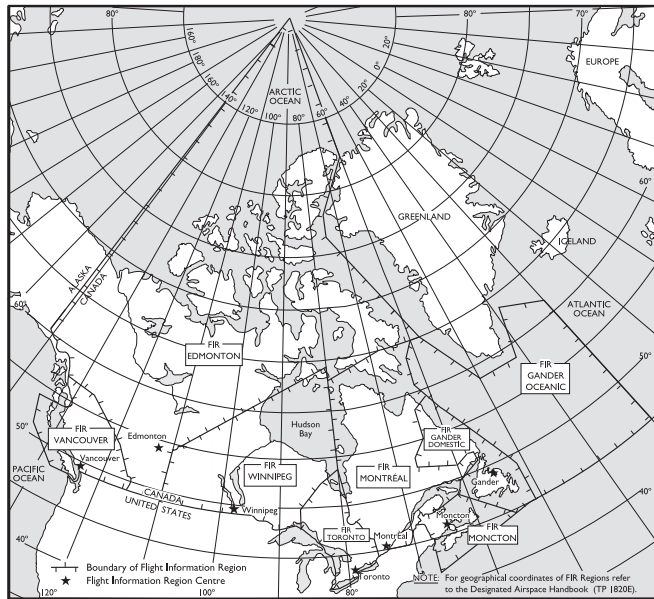

2.5 Controlled Airspace

Controlled airspace is the airspace within which air traffic control service is provided and within which some or all aircraft may be subject to air traffic control. Types of controlled airspace are:

- (a) in the High-Level Airspace:
 - the Southern, Northern and Arctic Control Areas.

NOTE:

Encompassed within the above are high-level airways, the upper portions of some military terminal control areas and terminal control areas.

- (b) in the Low-Level Airspace:
 - low-level airways,
 - terminal control areas,
 - control area extensions,
 - control zones,
 - transition areas,
 - military terminal control areas.

2.5.1 Use of Controlled Airspace by Visual Flight Rules (VFR) Flights

Due to the speeds of modern aircraft, the difficulty in visually observing other aircraft at high altitudes and the density of air traffic at certain locations and altitudes, the “see and be seen” principle of VFR separation cannot always provide positive separation. Accordingly, in certain airspace and at certain altitudes VFR flight is either prohibited or subject to specific restrictions prior to entry and during flight.

2.5.2 Aircraft Speed Limit Order

According to CAR 602.32, no person shall operate an aircraft in Canada:

- (a) below 10 000 ft ASL at more than 250 KIAS; or
- (b) below 3 000 ft AGL within 10 NM of a controlled airport and at more than 200 KIAS, unless authorized to do so in an air traffic control clearance.

Exceptions

- (a) A person may operate an aircraft at an indicated airspeed greater than the airspeeds referred to in (a) and (b) above where the aircraft is being operated in accordance with a special flight operations certificate – special aviation event issued under CAR 603.
- (b) If the minimum safe speed, given the aircraft configuration, is greater than the speed referred to in (a) or (b) above, the aircraft shall be operated at the minimum safe speed.

Notifying ATC

On departure, when intending to operate at speeds exceeding 250 KIAS below 10 000 ft ASL, pilots must, on initial contact, notify the departure controller of the reason for this action.

ATC requires this information for the following reasons:

- (a) for operational considerations regarding other traffic, particularly in potential overtake situations; and
- (b) so that ATC will know that the request or notification of intent to operate above the speed limit is for “*minimum safe speed*” requirements and will therefore not file an Aviation Occurrence Report.

The phraseology of “*minimum safe speed XXX kt*” is encouraged and ATC will acknowledge.

Example: *Montreal Centre, ACA123, minimum safe speed 270 kt*

As ATC is not authorized to approve a speed greater than 250 KIAS below 10 000 ft ASL, the phraseology “request high-speed climb” should not be used.

2.6 High-Level Controlled Airspace

Controlled airspace within the High-Level Airspace is divided into three separate areas. They are the Southern Control Area (SCA), the Northern Control Area (NCA) and the Arctic Control Area (ACA). Their lateral dimensions are illustrated in Figure 2.3. Figure 2.4 illustrates their vertical dimensions which are: SCA, 18 000 ft ASL and above; NCA, FL 230 and above; ACA, FL 270 and above.

Pilots are reminded that both the NCA and the ACA are within the Northern Domestic Airspace; therefore, compass indications may be erratic, and true tracks are used in determining the flight level at which to fly. In addition, the airspace from FL 330 to FL 410 within the lateral dimensions of the NCA, the ACA and the northern part of the SCA has been designated CMNPS airspace. (See AIP Canada ENR 2.2)

Figure 2.3—Southern, Northern and Arctic Control Areas

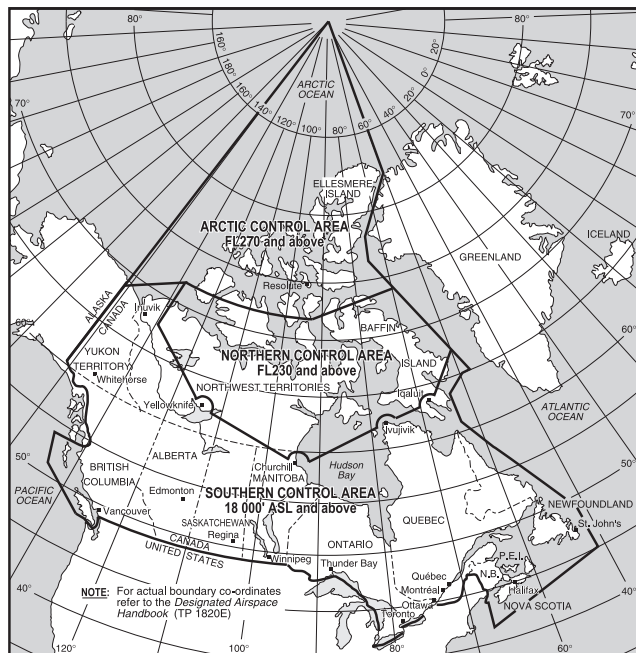
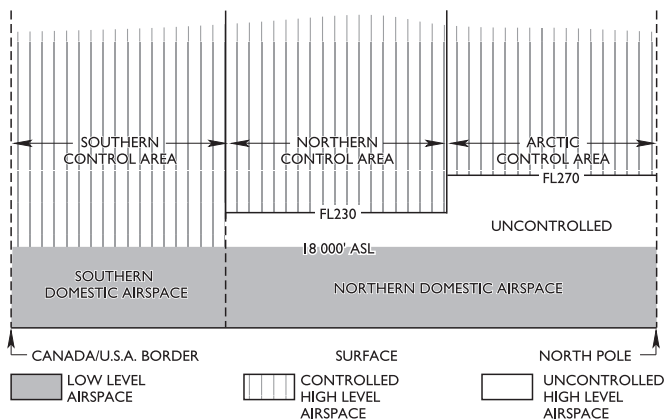

Figure 2.4—Vertical Dimensions of Southern, Northern and Arctic Control Areas



2.7 Low-Level Controlled Airspace

2.7.1 Low-Level Airways

Controlled low-level airspace extends upward from 2 200 ft AGL up to, but not including, 18 000 ft ASL, within the following specified boundaries:

- (a) **VHF/UHF Airways:** The basic VHF/UHF airway width is 4 NM on each side of the centreline prescribed for such an airway. Where applicable, the airway width shall be increased between the points where lines, diverging 4.5° on each side of the centreline from the designated facility, intersect the basic width boundary; and where they meet, similar lines projected from the adjacent facility.

Figure 2.5(a)—VHF/UHF Airway Dimensions

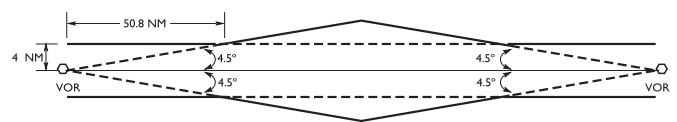

Where a Victor airway is established based on a VOR/VORTAC and NDB, the boundaries of that airway will be those of an LF/MF airway [see Figure 2.5(b)].

Figure 2.5(b)—VHF/UHF Airway Based on VOR and NDB

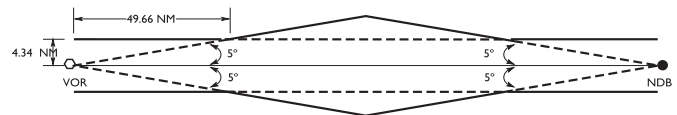

- (b) **LF/MF Airways:** The basic LF/MF airway width is 4.34 NM on each side of the centreline prescribed for such an airway. Where applicable, the airway width shall be increased between the points where lines, diverging 5° on each side of the centreline from the designated facility, intersect the basic width boundary; and where they meet, similar lines projected from the adjacent facility.

Figure 2.6—LF/MF Airway Dimensions

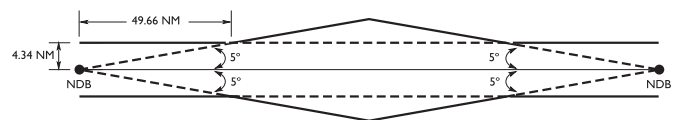

RAC

- (c) **T-Routes:** Low-level controlled fixed RNAV routes have dimensions of 4 NM of primary obstacle protection area, plus 2 NM of secondary obstacle protection area on each side of the centreline. The airspace associated with RNAV T-routes is 10 NM on each side of the centreline. RNAV T-route airspace and protection areas do not splay.

Figure 2.7(a)—Fixed RNAV Route

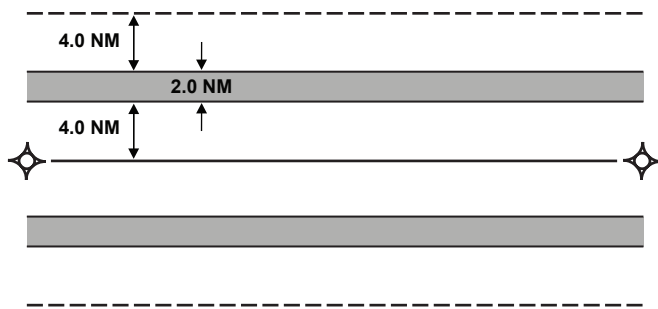
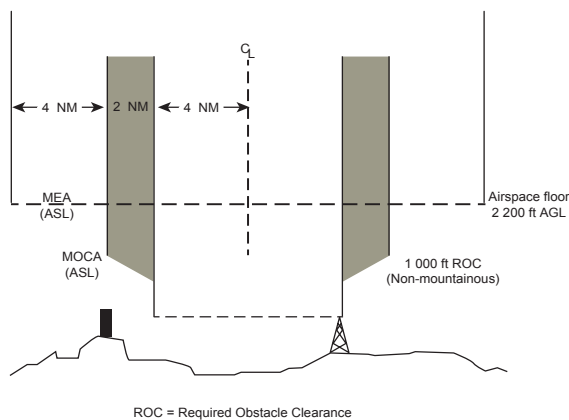

Figure 2.7(b)—Fixed RNAV Route Cross Section



2.7.3 Control Zones

Control zones are designated around certain aerodromes to keep IFR aircraft within controlled airspace during approaches and to facilitate the control of VFR and IFR traffic.

Control zones having a civil control tower within a terminal control area normally have a 7-NM radius. Others have a 5-NM radius, with the exception of a few which have a 3-NM radius. Control zones are capped at 3 000 ft AAE unless otherwise specified. Military control zones usually have a 10-NM radius and are capped at 6 000 ft AAE. All control zones are depicted on VFR aeronautical charts and the Enroute Low Altitude Charts. Control zones will be classified as “B”, “C”, “D” or “E” depending on the classification of the surrounding airspace.

The VFR weather minima for control zones are outlined in Table 2.2. When weather conditions are below VFR minima, a pilot operating VFR may request special VFR (SVFR) authorization in order to enter the control zone. This authorization is normally obtained through the local tower or FSS, and must be obtained before SVFR is attempted within a control zone. ATC will issue an SVFR authorization, traffic and weather conditions permitting, only upon a request for SVFR from a pilot. SVFR will not be initiated by ATS. Once having received SVFR authorization, the pilot continues to remain responsible for avoiding other aircraft and weather conditions beyond the pilot’s own flight capabilities and the capabilities of the aircraft.

2.7.2 Control Area Extensions

Control area extensions are designated around aerodromes where the controlled airspace provided is insufficient to permit the required separation between IFR arrivals and departures and to contain IFR aircraft within controlled airspace. A control area extension provides:

- (a) additional controlled airspace around busy aerodromes for IFR control. The controlled airspace contained within the associated control zone and airway(s) width is not always sufficient to permit the manoeuvring required to separate IFR arrivals and departures; or
- (b) connecting controlled airspace, e.g. a control area extension is used to connect a control zone with the en route structure.

Control area extensions are based at 2 200 ft AGL unless otherwise specified and extend up to, but not including 18 000 ft ASL. Some control area extensions, such as those which extend to the oceanic controlled airspace, may be based at other altitudes such as 2 000, 5 500 or 6 000 ft ASL. The outer portions of some other control area extensions may be based at higher levels. Even if described with an ASL floor, the base of a Control Area Extension shall not extend lower than 700 ft AGL.

Table 2.2—VFR Weather Minima*

AIRSPACE		FLIGHT VISIBILITY	DISTANCE FROM CLOUD	DISTANCE AGL
Control Zones		not less than 3 mi.**	horizontally: 1 mi. vertically: 500 ft	vertically: 500 ft
Other Controlled Airspace		not less than 3 mi.	horizontally: 1 mi. vertically: 500 ft	—
Uncontrolled Airspace	1 000 ft AGL or above	not less than 1 mi. (day) 3 mi. (night)	horizontally: 2 000 ft vertically: 500 ft	—
	below 1 000 ft AGL – all aircraft except helicopters	not less than 2 mi. (day) 3 mi. (night) (see Note 1)	clear of cloud	—
	below 1 000 ft AGL – helicopter	not less than 1 mi. (day) 3 mi. (night) (see Note 2)	clear of cloud	—

* See CAR 602, Division VI – Visual Flight Rules

** Ground visibility when reported

NOTES:

1. Notwithstanding CAR 602.115, an aircraft other than an helicopter may be operated in visibilities less than 2 miles during the day, when authorized to do so in an air operator certificate or in a private operator certificate.
2. Notwithstanding CAR 602.115, a helicopter may be operated in visibilities less than 1 mile during the day, when authorized to do so in an air operator certificate or in a flight training unit operator certificate helicopter.

Special VFR weather minimum and requirements applicable within control zones are found in CAR 602.117, and are summarized as follows:

Where authorization is obtained from the appropriate ATC unit, a pilot-in-command may operate an aircraft within a control zone, in IFR weather conditions without compliance with the IFR, where flight visibility and, when reported, ground visibility are not less than:

- (a) 1 mile for aircraft other than helicopters; and
- (b) 1/2 mile for helicopters.

NOTES:

1. All aircraft, including helicopters, must be equipped with a radio capable of communicating with the ATC unit and must comply with all conditions issued by the ATC unit as part of the SVFR authorization.
2. Aircraft must operate clear of cloud and within sight of the ground at all times.
3. Helicopters should operate at such reduced airspeeds so as to give the pilot-in-command adequate opportunity to see other air traffic or obstructions in time to avoid a collision.
4. When the aircraft is not a helicopter and is being operated at night, ATC will only authorize special VFR where the authorization is for the purpose of allowing the aircraft to land at the destination aerodrome.

Table 2.3—Special VFR Weather Minima (control zones only)

—	Flight Visibility (Ground when reported)	Distance from cloud
Aircraft other than Helicopter	1 mile	Clear of cloud
Helicopter	1/2 mile	

2.7.4 Visual Flight Rules (VFR) Over-the-Top

A person may operate an aircraft VFR over-the-top (VFR OTT), provided certain conditions are met. Those conditions include weather minima, aircraft equipment and pilot qualifications. Pilots should indicate that the flight is VFR OTT during communications with ATS units. Deviations from the intended route of flight may be necessary when transiting CZs or TCAs. Pilots should take into consideration the additional fuel requirements this may cause.

CAR 602.116 specifies the weather minima for VFR OTT. A summary of the minima follows:

- (a) VFR OTT is allowed during the day only, and during the cruise portion of the flight only.
- (b) The aircraft must be operated at a vertical distance from cloud of at least 1 000 ft.
- (c) Where the aircraft is operated between two cloud layers, those layers must be at least 5 000 ft apart.
- (d) The flight visibility at the cruising altitude of the aircraft must be at least 5 mi.
- (e) The weather at the destination aerodrome must have a sky condition of scattered cloud or clear, and a ground visibility of 5 mi. or more, with no forecast of precipitation, fog, thunderstorms, or blowing snow, and these conditions must be forecast to exist
 - (i) in the case of an aerodrome forecast (TAF), for the period from 1 hr before to 2 hr after the ETA; and
 - (ii) in the case of an area forecast (GFA) because a TAF is not available, for the period from 1 hr before to 3 hr after the ETA.

CARs 605.14 and 605.15 outline the aircraft equipment requirements for VFR OTT. In part, the equipment requirements are the same as for VFR flight, with extra requirements for VFR OTT.

Pilot qualifications for VFR OTT flight are specified in CARs Part IV—*Personnel Licensing and Training*.

2.7.5 Transition Areas

Transition areas are established when it is considered advantageous or necessary to provide additional controlled airspace for the containment of IFR operations.

Transition areas are of defined dimensions, based at 700 ft AGL unless otherwise specified, and extend upwards to the base of overlying controlled airspace. The area provided around an aerodrome will normally be 15 NM radius of the aerodrome coordinates, but shall be of sufficient size to contain all of the aerodrome published instrument approach procedures. Even if described with an ASL floor, the base of a transition area shall not extend lower than 700 ft AGL.

2.7.6 Terminal Control Areas

Terminal control areas are established at high volume traffic airports to provide an IFR control service to arriving, departing and en route aircraft. Aircraft operating in the TCA are subject to certain operating rules and equipment requirements. The TCA operating rules are established by the classification of the airspace within the TCA. These rules will be based on the level of ATC service that is appropriate for the number and type of aircraft using the airspace as well as the nature of the operations being conducted.

A TCA is similar to a control area extension except that:

- (a) a TCA may extend up into the high-level airspace;
- (b) IFR traffic is normally controlled by a terminal control unit. The ACC will control a TCA during periods when a TCU is not in operation; and
- (c) TCA airspace will normally be designed in a circular configuration, centred on the geographic coordinates of the primary aerodrome. The outer limit of the TCA should be at 45 NM radius from the aerodrome geographic coordinates based at 9 500 ft AGL, with an intermediate circle at 35 NM based at 2 200 ft AGL and an inner circle at 12 NM radius based at 1 200 ft AGL. Where an operational advantage may be gained, the area may be sectorized. For publication purposes the altitudes may be rounded to the nearest appropriate increment and published as heights ASL. The floor of a TCA shall not extend lower than 700 ft AGL.

A military terminal control area is the same as a TCA, except that special provisions prevail for military aircraft while operating within the MTCA. MTCAs may be designated at selected military aerodromes where the control service will be provided by a military TCU, or by ATC, through agreement with DND.

2.8 Airspace Classification

Canadian Domestic Airspace (CDA) is divided into seven classes, each identified by a single letter—A, B, C, D, E, F or G. Flight within each class is governed by specific rules applicable to that class, and the rules are contained in *Canadian Aviation Regulation* (CAR) 601, which can be found at <<https://lois-laws.justice.gc.ca/eng/regulations/SOR-96-433/FullText.html#s-601.01>>.

The air traffic services available and the rules for operating within a particular portion of airspace depend on the classification of that airspace and not on the name by which it is commonly known. Thus, the air traffic services available and the rules for flight within a high-level airway, a terminal control area (TCA), or a control zone (CZ) depend on the class of airspace within all or part of the defined area. Weather minima are specified for controlled or uncontrolled airspace, not for each class of airspace. For more information on Canada's airspace classification and structure, please see Figure 2.8. A printable copy of Figure 2.8 is available at <https://tc.canada.ca/sites/default/files/migrated/tc_6010_airspaceposter_e.pdf>.

Figure 2.8—Canada’s Airspace (TP 6010)

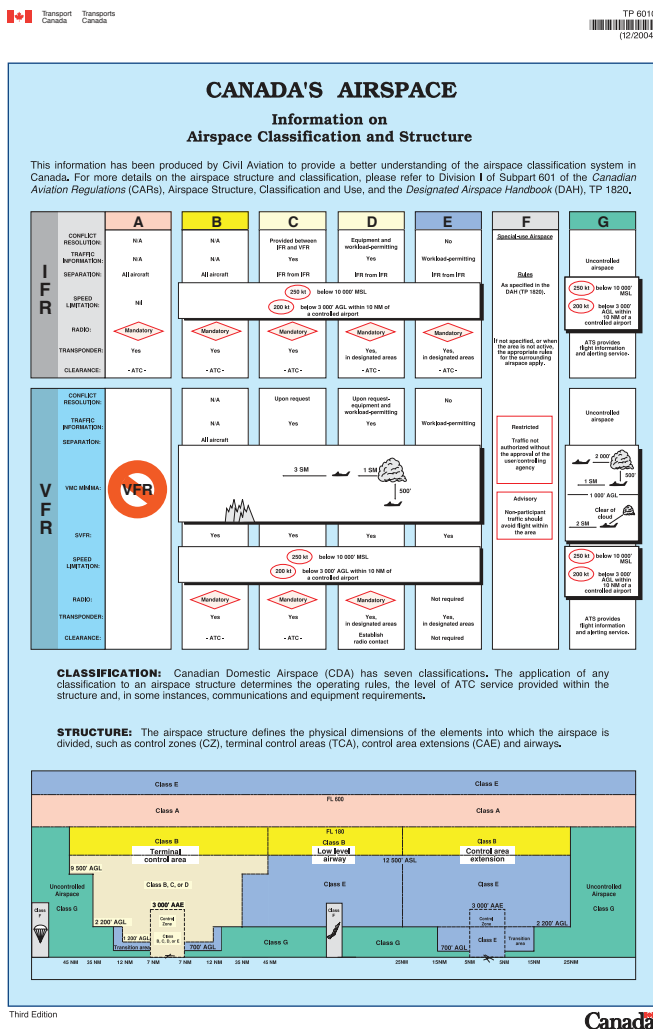

Third Edition



2.8.1 Class A Airspace

Class A airspace is designated where an operational need exists to exclude VFR aircraft.

All operations must be conducted under IFR and are subject to ATC clearances and instructions. ATC separation is provided to all aircraft.

All aircraft operating in Class A airspace must be equipped with a transponder and automatic pressure-altitude reporting equipment, including ADS-B, as detailed in section 551.103 of the *Airworthiness Manual* Chapter 551 - Aircraft Equipment and Installation, available here: <https://tc.canada.ca/en/corporate-services/acts-regulations/list-regulations/canadian-aviation-regulations-sor-96-433/standards/airworthiness-chapter-551-aircraft-equipment-installation-canadian-aviation-regulations-cars#551_103>.

Class A airspace will be designated from the base of all high-level controlled airspace, or from 700 ft AGL, whichever is higher, up to and including FL 600.

2.8.2 Class B Airspace

Class B airspace is designated where an operational need exists to provide ATC service to IFR aircraft and to control VFR flights.

Operations may be conducted under IFR or VFR. All aircraft are subject to ATC clearances and instructions. ATC separation is provided between all aircraft. VFR flights are conducted as controlled VFR flights (see RAC 5.6).

All low-level controlled airspace above 12 500 ft ASL or at and above the MEA, whichever is higher, up to but not including 18 000 ft ASL, will be Class B airspace.

Control zones and associated terminal control areas may also be classified as Class B airspace.

NOTES:

1. No person shall operate an aircraft in Class B controlled airspace in VFR flight unless:
 - (a) the aircraft is equipped with:
 - (i) radio communication equipment capable of two-way communication with the appropriate ATS facility;
 - (ii) radio navigation equipment capable of using navigation facilities to enable the aircraft to be operated in accordance with the flight plan; and
 - (iii) a transponder and automatic pressure-altitude reporting equipment.
 - (b) a continuous listening watch is maintained by a flight crew member on a radio frequency assigned by ATC;
 - (c) except as otherwise authorized by ATC, when the aircraft is over a reporting point a position report is transmitted to the appropriate unit or, when so directed by ATC, to an FSS; and
 - (d) the aircraft is operated in VMC at all times.
2. A person operating an aircraft on a VFR flight in Class B airspace shall operate the aircraft in VMC at all times. When it becomes evident that flight in VMC will not be possible at the altitude or along the route specified, the pilot shall:
 - (a) request an ATC clearance that will enable the aircraft to be operated in VMC to the filed destination, or to another aerodrome;
 - (b) where the person is the holder of a valid instrument rating, request an IFR clearance for flight under the instrument flight rules; or
 - (c) where the Class B airspace is a control zone, request an authorization for special VFR flight.



3. A person operating an aircraft in Class B controlled airspace in VFR flight who is unable to comply with the requirements of the preceding paragraphs shall ensure that:
- (a) the aircraft is operated in VMC at all times;
 - (b) the aircraft leaves Class B controlled airspace:
 - (i) by the safest and shortest route, either exiting horizontally or descending, or
 - (ii) when that airspace is a control zone, by landing at the aerodrome on which the control zone is based; and
 - (c) an ATC unit is informed as soon as possible of the actions taken pursuant to paragraph (b).

2.8.3 Class C Airspace

Class C airspace is a controlled airspace within which both IFR and VFR flights are permitted, but VFR flights require a clearance from ATC to enter. ATC separation is provided between all aircraft operating under IFR. Conflict resolution is provided, when necessary, to resolve possible conflicts between VFR and IFR aircraft. All aircraft will be provided with traffic information. Conflict resolution between VFR aircraft can be provided upon request, after VFR aircraft are provided with traffic information. Runway separation is provided between all aircraft.

Traffic information is issued to advise pilots of known or observed air traffic which may be in proximity to their aircraft's position or intended route of flight warranting their attention. Conflict resolution is defined as the resolution of potential conflicts between IFR and VFR aircraft and between VFR aircraft that are identified and in communication with ATC.

Airspace classified as Class C becomes Class E airspace when the appropriate ATC unit is not in operation.

Terminal control areas and associated control zones may be classified as Class C airspace.

A person operating an aircraft in VFR flight in Class C airspace shall ensure that:

- (a) the aircraft is equipped with:
 - (i) radio communication equipment capable of two-way communication with the appropriate ATC unit, and
 - (ii) a transponder and automatic pressure-altitude reporting equipment, and
- (b) a continuous listening watch is maintained by a flight crew member on a radio frequency assigned by ATC.

A person wishing to operate an aircraft that is not equipped with functioning communication and transponder equipment for VFR flight in Class C airspace may, during daylight hours and in VMC, enter Class C airspace provided that permission to enter and operate within the airspace is obtained from ATC prior to the operation being conducted.

2.8.4 Class D Airspace

Class D airspace is a controlled airspace within which both IFR and VFR flights are permitted, but VFR flights must establish two-way communication with the appropriate ATC unit prior to entering the airspace. ATC separation is provided only between IFR aircraft. Aircraft will be provided with traffic information. Equipment and workload permitting, conflict resolution will be provided between VFR and IFR aircraft, and upon request between VFR aircraft. Runway separation is provided between all aircraft.

Airspace classified as Class D becomes Class E airspace when the appropriate ATC unit is not in operation.

A terminal control area and associated control zone could be classified as Class D airspace.

A person operating an aircraft in VFR flight in Class D airspace shall ensure that:

- (a) the aircraft is equipped with:
 - (i) radio communication equipment capable of two-way communication with the appropriate ATC unit, and
 - (ii) where the Class D airspace is specified as transponder airspace, a transponder and automatic pressure-altitude reporting equipment; and
- (b) a continuous listening watch is maintained by a flight crew member on a radio frequency assigned by ATC.

A person operating an aircraft in VFR flight that is not equipped with the required radio communication equipment may, during daylight hours in VMC, enter Class D airspace, provided that permission to enter is obtained from the appropriate ATC unit prior to operating within the airspace.

2.8.5 Class E Airspace

Class E airspace is designated where an operational need exists for controlled airspace but does not meet the requirements for Class A, B, C, or D.

Operations may be conducted under IFR or VFR. ATC separation is provided only between aircraft operating under IFR. VFR aircraft do not require permission to enter Class E airspace and, except for mandatory frequency areas (see RAC 4.5.4), are not required to establish communication with an ATIS unit prior to entering. Workload and equipment permitting, traffic information may be provided, upon request, to VFR aircraft. When requesting traffic information from ATC, pilots should be aware that air traffic controllers providing services in Class E airspace are responsible for larger volumes of airspace than those providing services in Class C or D airspace. As a result, there is a higher potential that workload and equipment limitations could affect the provision of traffic information, including potentially discontinuing this service without notification. A person operating an aircraft in VFR flight in Class E airspace remains responsible for maintaining a vigilant watch for, and avoiding, other traffic.

Aircraft are required to be equipped with a transponder and automatic pressure-altitude equipment to operate in Class E airspace that is specified as transponder airspace.

Low-level airways, control area extensions, transition areas, or control zones established without an operating control tower may be classified as Class E airspace.

2.8.6 Class F Airspace

Class F airspace is airspace of defined dimensions within which activities must be confined because of their nature, and within which limitations may be imposed upon aircraft operations that are not a part of those activities.

Class F airspace may be restricted airspace, advisory airspace, military operations areas, or danger areas and can be controlled airspace, uncontrolled airspace, or a combination of both. An advisory area, for example, may have the floor in uncontrolled airspace and the ceiling in controlled airspace. The significance, in this instance, is that the weather minima would be different in the controlled and uncontrolled portions.

Unless otherwise specified, the rules for the surrounding airspace apply in areas of Class F airspace, no matter if these areas are active or inactive.

Class F airspace is designated in the DAH (TP 1820) and published on the appropriate aeronautical charts.

2.8.6.1 Charting of Class F Airspace

All designated Class F restricted and advisory airspace is published on HI or LO charts, as applicable, and on VFR aeronautical charts.

Each restricted and advisory area within Canada has been assigned an identification code group, which consists of four parts:

- (a) Part (a) — the nationality letters CY;
- (b) Part (b) — the letter R for restricted area, the letter A for advisory area, or the letter D for danger area;
- (c) Part (c) — a three-digit number that identifies the area. This number indicates the Canadian region within which the area lies, as follows:
 - (i) 101 to 199 – British Columbia
 - (ii) 201 to 299 – Alberta
 - (iii) 301 to 399 – Saskatchewan
 - (iv) 401 to 499 – Manitoba
 - (v) 501 to 599 – Ontario
 - (vi) 601 to 699 – Quebec
 - (vii) 701 to 799 – New Brunswick, Nova Scotia, Prince Edward Island, Newfoundland and Labrador
 - (viii) 801 to 899 – Yukon Territory
 - (ix) 901 to 999 – Northwest Territories and Nunavut (including the Arctic Islands)

(d) Part (d) — in the case of advisory areas, the letter A, F, H, M, P, S or T in parentheses after the three-digit number that indicates the type of activity within the area, as follows:

- (i) A – acrobatic
- (ii) F – aircraft test
- (iii) H – hang gliding
- (iv) M – military operations
- (v) P – parachuting
- (vi) S – soaring
- (vii) T – training

Example:

The identification code group CYA113(A) means the following:

- (a) CY – indicates Canada
- (b) A – indicates advisory
- (c) 113 – indicates the number of an area in British Columbia
- (d) (A) – indicates acrobatic activity takes place within the area.

All altitudes will be inclusive, unless otherwise indicated (e.g. 5 000 to 10 000 ft). To indicate when either the bottom or upper altitude is not included, the words “below” and “above” will be placed before the appropriate altitude (e.g. above 5 000 to 10 000 ft, or 5 000 to below 10 000 ft).

ATC will maintain separation between IFR aircraft and active Class F airspace unless:

- (a) the pilot states that permission has been obtained from the user agency to enter the airspace;
- (b) the aircraft is operating on an altitude reservation approval (ALTRV APVL); or
- (c) the aircraft has been cleared for a contact or visual approach.

2.8.6.2 Danger Area (International Waters)

A danger area is Class F airspace that may be established over international waters but within Canada’s area of responsibility for providing ATS, as agreed to with ICAO. This is an airspace of defined dimensions within which activities dangerous to the flight of aircraft may exist at specified times. ATC clearances will not be issued for non-participating flights to enter a danger area. Aircraft should avoid flight in danger areas unless participating in the activity taking place therein.

2.8.6.3 Advisory Airspace

Airspace may be classified as Class F advisory airspace if it is airspace within which an activity occurs that, for flight safety purposes, non-participating pilots should be aware of, such as training, parachuting, hang gliding, and military operations.

Although not specifically restricted from operating therein, all aircraft are encouraged to avoid flight in advisory airspace unless participating in the activity taking place. If necessary, pilots of non-participating flights may enter advisory areas at their own discretion; however, extra vigilance is recommended. Pilots of

participating aircraft, as well as pilots flying through the area, are equally responsible for collision avoidance. ATC will normally ensure that IFR aircraft in controlled airspace remain clear of Class F advisory airspace. IFR aircraft shall be provided 500 ft vertical separation from an active Class F advisory airspace, unless wake turbulence minima are applicable, in which case 1 000 ft vertical separation shall be applied.

Pilots intending to fly in Class F advisory airspace are encouraged to monitor an appropriate frequency, to broadcast their intentions when entering and leaving the area, and to communicate, as necessary, with other users to ensure flight safety in the airspace. In a Class F advisory uncontrolled airspace area, 126.7 MHz would be an appropriate frequency.

NOTE:

Military operations in Class F airspace may be UHF only.

2.8.6.4 Restricted Airspace

A restricted area is airspace of defined dimensions above the land areas or territorial waters within which the flight of aircraft is restricted in accordance with certain specified conditions. Restricted airspace is designated for safety purposes when the level or type of aerial activity, the surface activity, or the protection of a ground installation requires the application of restrictions within that airspace.

No person may conduct aerial activities within active Class F restricted airspace unless permission has been obtained from the user agency. In some instances, the user agency may delegate a controlling agency the authority to approve access. In most cases, the controlling agency will be an ATC unit or an ANSP.

The user agency is the civil or military agency or organization responsible for the activity for which the Class F airspace has been provided. It has the jurisdiction to authorize access to the airspace when it is classified restricted. The user agency must be identified for Class F restricted airspace and, where possible, it should be identified for Class F advisory airspace.

There are two additional methods of restricting airspace.

- (a) CAR 601.16 is designed to allow the Minister to issue a NOTAM to restrict flight around and over forest fire areas or areas where forest fire control operations are being conducted. The provisions of this section can be invoked quickly via NOTAM by TC.
- (b) Section 5.1 of the *Aeronautics Act* allows the Minister to restrict flight in any airspace, for any purpose, by NOTAM. This authority is delegated by the Minister to cover specific situations for a temporary period, such as well fires, disaster areas, etc., for the purpose of ensuring safety of flight for air operations in support of the occurrence.

It should be noted that airspace that is restricted by invoking CAR 601.16 or section 5.1 of the *Aeronautics Act* is not Class F restricted airspace; the airspace has not been classified in accordance with the airspace regulations. This distinction is important to those who are charged with the responsibility for restricting airspace, since their actions are governed by the provisions of the *Statutory Instruments Act*.

2.8.6.5 Joint-Use Airspace

Joint-use airspace is Class F airspace within which operations may be authorized by the controlling agency when it is not being utilized by the user agency.

Class F restricted airspace should be available for use by non-participating aircraft when all or part of the airspace is not required for its designated purpose.

To ensure maximum utilization of restricted airspace, user agencies should be encouraged to make restricted airspace available for the conduct of operations or training of other agencies or commands on a joint-use basis.

An ATS unit may be designated to provide air traffic control or information service within the Class F airspace involved. A controlling agency will normally be assigned when there is joint use of the airspace.

2.8.6.6 NOTAM

It is permissible to designate Class F restricted airspace by NOTAM, if the following prerequisites are met:

- (a) the area of restricted airspace is required for a specified period of time of relative short duration (i.e. several hours or days); and
- (b) the appropriate NOTAM is issued at least 24 hours in advance of the area's activation.

2.8.7 Class G Airspace

Class G airspace is airspace that has not been designated Class A, B, C, D, E or F, and within which ATC has neither the authority nor the responsibility to exercise control over air traffic.

However, ATS units do provide flight information and alerting services. The alerting service will automatically alert SAR authorities once an aircraft becomes overdue, which is normally determined from data contained in the flight plan or flight itinerary.

In effect, Class G is all uncontrolled domestic airspace.

Low-level air routes are contained within Class G airspace. They are basically the same as a low-level airway, except that they extend upwards from the surface of the earth and are not controlled, and ATC separation is not provided to IFR or VFR aircraft. The lateral dimensions are identical to those of a low-level airway.

2.9 Other Airspace Divisions

Additional airspace divisions have been designated in order to increase safety or make allowances for the remote or mountainous regions within Canada. These divisions (or regions) are: altimeter setting region, standard pressure region and designated mountainous region.

2.9.1 Altitude Reservation

An altitude reservation is airspace of defined dimensions within controlled airspace reserved for the use of a civil or military agency during a specified period. An altitude reservation may be confined

to a fixed area (stationary) or moving in relation to the aircraft that operates within it (moving). Information on the description of each altitude reservation is normally published by NOTAM. Civil altitude reservations are normally for a single aircraft, while those for military use are normally for more than one aircraft.

Pilots should plan to avoid known altitude reservations. ATC will not clear an unauthorized flight into an active reservation. IFR and CVFR flights are provided with standard separation from altitude reservations.

2.9.2 Temporary Flight Restrictions—Forest Fires

In the interest of safe and efficient fire fighting operations, the Minister may issue a NOTAM restricting flights over a forest fire area to those operating at the request of the appropriate fire control authority (i.e. water bombers), or to those with written permission from the Minister.

The NOTAM would identify the following:

- (a) the location and dimensions of the forest fire area;
- (b) any airspace in which forest fire control operations are being conducted; and
- (c) the length of time during which flights are restricted in the airspace.

No person shall operate an aircraft in the airspace below 3 000 ft AGL within 5 NM of the limits of a forest fire area, or as described in a NOTAM (CARs 601.15, 601.16, and 601.17).

2.9.3 Flight Operations Over or in the Vicinity of Nuclear Power Plants

Pilots are reminded that overflights of nuclear power plants shall be carried out in accordance with the provisions of CAR 602.14(2) (see RAC 5.4).

Pilots should also be aware that loitering in the vicinity of, or circling, nuclear power plants should be avoided. Aircraft observed operating in this manner in the vicinity of nuclear power plants could be intercepted by government or law-enforcement aircraft, and escorted away from the facility to the nearest suitable aerodrome to be interviewed by police authorities.

2.9.4 Military Operations Areas

Regular military training activity, such as basic or advanced flight training or routine operational training, is typically carried out in Class F advisory airspace. More intensive operational training is normally reserved for Class F restricted airspace. Some non-hazardous military activity can still require increased coordination with ATC, but these exercises may not require advisory or restricted airspace to be designated.

Military operations areas (MOA) consist of airspace of defined dimensions established to segregate certain military activities from IFR traffic and to identify for VFR traffic where these activities are conducted. ATC will not clear a non-participating IFR aircraft through an active MOA, unless appropriate IFR separation can be provided. There is no need for VFR aircraft

to avoid flight into an MOA, but pilots should be alert for both large and small military aircraft that may be operating there at various altitudes and speeds.

MOAs can be designated in Class G airspace. User agencies and pilots operating in such MOAs should be aware that non-participating aircraft may legally operate under IFR or VFR without an ATC clearance in these MOAs.

MOAs will be included in the *Designated Airspace Handbook* and will be published on relevant aeronautical charts.

2.10 Altimeter Setting Region

The altimeter setting region is an airspace of defined dimensions below 18 000 feet ASL (see CAR 602.35 and Figure 2.9) within which the following altimeter setting procedures apply:

Departure – Prior to takeoff, the pilot shall set the aircraft altimeter to the current altimeter setting of that aerodrome or, if that altimeter setting is not available, to the elevation of the aerodrome.

En route – During flight the altimeter shall be set to the current altimeter setting of the nearest station along the route of flight or, where such stations are separated by more than 150 NM, the nearest station to the route of flight.

Arrival – When approaching the aerodrome of intended landing the altimeter shall be set to the current aerodrome altimeter setting, if available.

2.11 Standard Pressure Region

The standard pressure region includes all airspace over Canada at or above 18 000 feet ASL (the high-level airspace), and all low-level airspace that is outside of the lateral limit of the altimeter setting region (see Figure 2.9 and CAR 602.36). Within the standard pressure region the following flight procedures apply;

- (a) **General** – Except as otherwise indicated below, no person shall operate an aircraft within the standard pressure region unless the aircraft altimeter is set to standard pressure, which is 29.92 inches of mercury or 1013.2 mbs. (See Note).
- (b) **Departure** – Prior to takeoff the pilot shall set the aircraft altimeter to the current altimeter setting of that aerodrome or, if the altimeter setting is not available, to the elevation of that aerodrome. Immediately prior to reaching the flight level at which flight is to be conducted, the altimeter shall be set to standard pressure (29.92 inches of mercury or 1013.2 mbs). If the planned cruising flight level is above FL 180, resetting the altimeter to 29.92 inches of mercury or 1013.2 mbs at 18 000 ft ASL is acceptable and meets the requirement of CAR 602.36.
- (c) **Arrival** – Prior to commencing descent with the intention to land, the altimeter shall be set to the current altimeter setting of the aerodrome of intended landing, if available. However, if a holding procedure is conducted, the altimeter shall not be set to the current aerodrome altimeter setting until immediately prior to descending below the lowest flight level at which the holding procedure is conducted. Pilots of aircraft descending from cruising flight levels

above FL 180 may reset altimeters to the current altimeter setting of the aerodrome of intended landing when approaching FL 180 provided no holding or cruise level flight below FL 180 is to be made or anticipated.

- (d) **Transition – CAR 602.37 – Altimeter Setting and Operating Procedures in Transition between Regions**, specifies that except as otherwise authorized by ATC, aircraft progressing from one region to another shall make the change in the altimeter setting while within the standard pressure region prior to entering, or after leaving, the altimeter setting region. If the transition is to be made into the altimeter setting region while in level cruising flight, the pilot should obtain the current altimeter setting from the nearest station along the route of flight as far as practical before reaching the point at which the transition is to be made. When climbing from the altimeter setting region into the standard pressure region, pilots shall set their altimeters to standard pressure (29.92 inches of mercury or 1013.2 mbs) immediately after entering the standard pressure region. When descending into the altimeter setting region, pilots shall set their altimeters to the appropriate station altimeter setting immediately prior to descending into the altimeter setting region. Normally, the pilot will receive the appropriate altimeter setting as part of the ATC clearance prior to descent. If it is not incorporated in the clearance, it should be requested by the pilot.

NOTE:

When an aircraft is operating in the standard pressure region with standard pressure set on the altimeter subscale, the term “flight level” is used in lieu of “altitude” to express its height. Flight level is always expressed in hundreds of feet. For example FL 250 represents an altimeter indication of 25 000 ft; FL 50, an indication of 5 000 ft.

Figure 2.9—Altimeter Setting and Standard Pressure Regions



2.12 Mountainous Regions

Designated mountainous regions are areas of defined lateral dimensions, specified in the *Designated Airspace Handbook*, above which special rules concerning minimum IFR altitudes to ensure obstacle clearance (CAR 602.124) apply.

An aircraft, when operated in accordance with IFR within designated mountainous regions, but outside of areas for which minimum altitudes for IFR operations have been established (including minimum vectoring altitudes, MOCAs, transition altitudes, 100NM safe altitudes, MSAs and AMAs), shall be flown at an altitude of at least 2000 feet above the highest obstacle within 5NM of the aircraft in flight when in areas 1 and 5, and at least 1500 feet above the highest obstacle within 5NM when in areas 2, 3 and 4. (See Figure 2.10.)

As minimum en route IFR altitudes have been established for designated airways and air routes, such minimum altitudes shall be applied when flying in accordance with IFR along airways or air routes within designated mountainous regions, except that aircraft should be operated at an altitude which is at least 1000 feet higher than the minimum en route IFR altitude, when there are large variations in temperature and/or pressure. (See RAC 8.6)

Figure 2.10—Designated Mountainous Regions in Canada



RAC

2.13 Emergency Communications and Security

The rules for operating within the Air Defence Identification Zone (ADIZ) are specified in CAR 602.145 – ADIZ, and are repeated in RAC 3.8.

Figure 2.11—Air Defence Identification Zone (ADIZ)

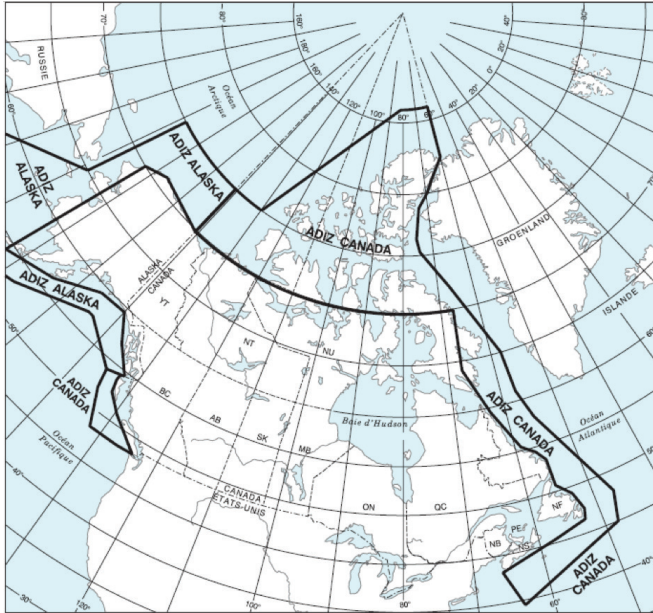

A specific FIC may be contacted at the number shown in the CFS or CWAS, General section, Flight Planning (FLT PLN) subsection. Collect calls from pilots are accepted at all FICs.

When requesting a briefing, identify yourself as a pilot; provide the aircraft identification and the following:

- type of flight (VFR, IFR, CVFR, composite) planned;
- type of aircraft;
- aerodrome of departure and estimated time of departure (ETD);
- destination aerodrome and estimated elapsed time (EET);
- planned cruising level(s) or altitude(s);
- route to be flown and estimated times of arrival at, and departure from, any intermediate aerodrome(s);
- alternate aerodrome, if appropriate;
- type of meteorological information requested, i.e. whether a briefing or consultation; and
- information already on hand, if any.

The flight service specialist requires this information to tailor the briefing to the planned flight and the needs of the pilot. The flight service specialist may omit information normally provided in a briefing if the pilot has indicated having the data on hand or requested the briefing be limited to specific information. The flight service specialist will terminate the briefing by soliciting flight plan information not already obtained at the beginning of the briefing and PIREP, if appropriate.

3.0 Flight Planning

3.1 General

The flight planning requirements contained in this Section are based, in part, on the CAR, Part VI, General Operating and Flight Rules.

The pilot-in-command of an aircraft shall, before commencing a flight, be familiar with the available information that is appropriate to the intended flight (CAR 602.71).

The pilot-in-command of an aircraft shall, before commencing a flight, be familiar with the available weather information that is appropriate to the intended flight (CAR 602.72). Pilots should refer to the MET Section for aviation weather information.

3.2 Pilot Briefing Service

The pilot briefing service is provided by FICs to assist pilots at the pre-flight planning stage and for information updates while en route. Pilot requests for initial briefings while airborne are not encouraged because this practice leads to frequency congestion.

The telephone numbers of NAV CANADA FICs are found in the General and Aerodrome/Facility Directory sections of the CFS or CWAS. Long distance phone calls can be made to a FIC toll-free at 1-866-WXBRIEF (1-866-992-7433). A call to this number is routed to the FIC that serves the area from which the call originates. A call to 1-866-GOMÉTÉO (1-866-466-3836) is routed to the Québec FIC for the provision of bilingual service.

3.3 Aeronautical Information

Aeronautical information (NOTAM, RSC, CRFI, flow control, etc.) is available at ATS units and at certain operations offices. Aeronautical information is routinely provided by FICs during a pilot briefing and upon request in FISE. Telephone numbers and RCO frequencies for all FICs are listed in the CFS and the CWAS.

Canadian domestic NOTAMs are disseminated via the aeronautical fixed service (AFS) and stored electronically in accordance with a NOTAM series concept. NOTAMs are further divided as aerodrome NOTAM and flight information region (FIR) NOTAM in accordance with the subject and impact. Before commencing a flight, pilots must ensure that each pertinent NOTAM series and type has been reviewed, so that they are familiar with all appropriate NOTAMs for the intended flight.

All Canadian NOTAMs, with the exception of RSC NOTAM, are composed and disseminated in the International Civil Aviation Organization (ICAO) format. Canadian NOTAM series have different distribution lists and dissemination categories. For more details on series, NOTAM regions, and dissemination categories, refer to *AIP Canada* section GEN 3.1.3.

3.4 Weight and Balance Control

3.4.1 Definitions

The following definitions and abbreviations are used in weight and balance control:

(a) **Actual weight** is the weight, when referenced to passenger weight, derived by the weighing of each passenger just prior to flight boarding, and then adding the allowances for personal clothing and carry-on baggage. Infants shall be weighed along with their accompanying adult. Where weighing scales are not available or serviceable, or the passenger refuses to be weighed, the following weights may be used in lieu of actual weight.

(i) **Volunteered weight** is the weight obtained by asking the passenger for their weight, adding 4.5 kg (10 lb) to the disclosed weight, and then adding the allowances for personal clothing and carry-on baggage.

(ii) **Estimated weight** is the reasonable estimate of the passenger's weight made by the operator, where actual weight is not available and volunteered weight is either not provided or is deemed to be understated, to which allowances are then added for personal clothing and carry-on baggage.

NOTE:

Personnel who board passengers should, with a reasonable degree of accuracy, be able to assess the validity of a passenger's volunteered weight, or estimate the weight, and shall include allowances for personal clothing and carry-on baggage. Where necessary, the volunteered weight should be appropriately increased so as to avoid gross inaccuracies.

(b) **Air operator segmented weights** are the approved segmented weights derived by the air operator from statistically meaningful data using a methodology that is acceptable to the Minister. They may be used in lieu of TCCA published segmented weights and are applicable only to that air operator. Furthermore, the weights may be used only in circumstances consistent with those under which the survey was conducted.

(c) **Air operator standard weights** are the approved standard weights derived by the air operator from statistically computed data in accordance with procedures that are acceptable to the Minister. They may be used in lieu of the standard weights published by TCCA and are applicable only to that air operator. Furthermore, the weights may be used only in circumstances consistent with those under which the survey was conducted.

(d) **Basic empty weight** is the basic weight of the aircraft as determined in accordance with the aircraft flight manual (AFM).

(e) **Carry-on baggage** is the baggage that a passenger may carry on board. Based on the particular aircraft stowage limitations, the operator may limit the number, size, shape and weight of the carry-on baggage to enable it to be stowed under the

passenger seat or in the storage compartment. Otherwise, the standard allowance is 5.9 kg (13 lb) of carry-on baggage per passenger and this remains constant throughout the year. Carry-on baggage weight shall be included in the weight of the passenger for the purpose of weight and balance calculation.

NOTE:

The only circumstance under which the weight of the carry-on baggage may not be added to the weight of each passenger is when no carry-on baggage is permitted on the flight.

(f) **Checked baggage** is baggage that is individually checked in, weighed and placed in the cargo compartment of the aircraft. This includes baggage that is too large to be placed in the cabin of the aircraft and baggage that must be carried in the cargo compartment by regulation, security program, or company policy. For baggage checked plane-side, see the definition for plane-side loaded bag.

(g) **Empty weight** is the total weight of the following parts or contents, which are part of, or carried on board, the aircraft:

- (i) the airframe, including the rotor of a helicopter or gyroplane;
- (ii) the power plant;
- (iii) the fixed ballast;
- (iv) the unusable fuel;
- (v) the maximum amount of normal operating fluids, including oil, power-plant coolant, hydraulic fluid, de-icing fluid and anti-icing fluid, but not including potable water, lavatory pre-charge fluid or fluid intended for injection into the engines; and
- (vi) all of the installed equipment.

(h) **Large aeroplane** is an aeroplane with an maximum certificated take-off weight (MCTOW) of over 5 700 kg (12 566 lb).

(i) **Maximum certificated take-off weight (MCTOW)** is weight identified as such in an aircraft type certificate.

(j) **Maximum permissible take-off weight or maximum take-off weight (MTOW)** is the maximum take-off weight for an aircraft as authorized by the aircraft's state of registry or as provided for in the aircraft type certificate.

(k) **On board weight and balance system** is a system that weighs the aircraft and its payload and then calculates the centre of gravity (CG) using equipment on board the aircraft.

(l) **Operational empty weight** is the actual weight of the aircraft before loading for dispatch. The operational empty weight may include removable equipment, flight crew members and crew members (including baggage), oil, unusable fuel, as well as emergency equipment, and should be defined by the air operator. It does not include usable fuel and payload.

(m) **Operations personnel** is the personnel whose duties and responsibilities involve maintenance, loading, unloading, dispatching, servicing, weight and balance, passenger escort, scheduling, de-icing, or working on the ramp. This also

includes members of the flight crew and cabin crew, as well as anyone involved in the aircraft's operation.

- (n) **Passenger** is a person, other than a crew member, who is carried on board an aircraft and who, for weight and balance control, is categorized as a(n):
 - (i) **Adult**—a person, regardless of sex, who is aged 12 years or older and who may be subcategorized as male or female;
 - (ii) **Child**—a person (male or female) who is between two to less than 12 years of age; or
 - (iii) **Infant**—a baby who is less than two years of age.
- (o) **Personal clothing allowance** is the weight of personal clothing that a passenger carries on board the aircraft, which is standardized as 3.6 kg (8 lb) for summer and 6.4 kg (14 lb) for winter and must be added to the passenger's weight for the purpose of weight and balance calculation.
- (p) **Plane-side loaded bag** is any bag or item that is placed at the door or steps of an aircraft because it cannot be accommodated as carry-on baggage and that is subsequently placed in the aircraft cargo compartment or cargo bin.
- (q) **Segmented weights** are the statistically derived average adult (male or female) passenger weights modified by appropriate standard deviations so as to be representative of small passenger groups and provide a predetermined degree of confidence and accuracy (tolerance) that the actual weight of the passenger group will not exceed the weight calculated by using segmented weight values. The segmented weight table identifies weight values that are modified to cater for variations in aircraft passenger seating capacity and include personal clothing and carry-on baggage allowances. In the Canadian context, segmented weights are applicable only for aeroplanes that are certificated for passenger seating capacity of five or more and are being operated under Subpart 703 of the CARs.

NOTE:

Segmented weights should be used where actual weights, volunteered weights or estimated weights are not available or cannot be used.

- (r) **Small aircraft** is an aircraft with a maximum permissible take-off weight of 5 700 kg (12 566 lb) or less, or a helicopter with a maximum permissible take-off weight of 2 730 kg (6 018 lb) or less.
- (s) **Standard weights** are the weights published by TCCA as standard average passenger weights, including personal clothing and carry-on baggage allowances, for use in weight and balance calculations that do not involve actual weighing.

3.4.2 Weight Control

Pilots must recognize the effect of weight and balance on the performance and handling of aircraft, particularly in combination with performance-reducing factors, such as contaminated runways, aircraft icing, degraded engine performance, severe or uncoordinated manoeuvres, turbulence, high ambient temperatures and emergency situations.

It is mandatory to calculate weight and balance accurately for every flight and ensure that they are within the aircraft's permissible limits in order to comply with the aircraft airworthiness certificate and conform to the regulations. Before the aircraft takes off, it is important that the PIC of the aircraft ensure that the load carried by the aircraft is of an appropriate weight; the weight must be distributed and secured so that it may be carried safely on the intended flight. If weight and CG (balance) limitations are not observed, then the pilot has failed to comply with a legal condition for the operation of the aircraft and the airworthiness certificate is nullified.

It must be recognized that with many four- and six-seat aircraft, it is not possible to fill all the seats, use the maximum baggage allowance, fill all the fuel tanks and still remain within the approved weight and CG limitations.

Estimating baggage weight can result in gross inaccuracies. If it is possible that the aircraft is operating close to its MTOW, the baggage must be weighed. Even a pocket-sized spring balance can be used as a handy standby if weighing scales are not available. This reduces the risk involved in guesswork. Note that on some aircraft, restrictions are placed on rear-seat occupancy if the maximum baggage allowance is used. When the aircraft is carrying freight, check for discrepancies with the declared weight. Ensure that the weight per unit area limitation on the baggage compartment floor is not exceeded. It is critical to ensure that the baggage/freight is properly stowed, cannot move during flight, and does not obstruct exits or access to emergency equipment. If the aircraft is suspected to be operating anywhere close to its maximum weight, passengers must be weighed. The risk of embarrassment is not a reason for risking safety or crossing weight limits. It is important to remember that a passenger's weight is not his or her stripped weight, but must include personal clothing and carry-on baggage allowances.

Fuel is supplied in pounds, kilograms, litres or gallons. Pilots should note which unit is being used and calculate the fuel weight accordingly. Incorrect conversion could be hazardous in terms of endurance and fuel weight estimation.

3.4.3 Balance

Balance refers to the location of the CG along the longitudinal axis of the aircraft. There are forward and aft limits established during certification flight testing; they are the maximum CG positions at which the longitudinal stability requirements can be met. If an aircraft is being operated outside these limits, its handling is either unsatisfactory or has not been investigated. The limits for each aircraft are contained in the pilot operating handbook and the AFM. The aircraft must not be flown outside these limits.

In many aircraft, there is significant CG movement as fuel is being consumed; pilots should familiarize themselves with how this affects their aircraft.

3.4.4 Operational Requirements

It is the responsibility of the PIC of the aircraft to ensure that the weight and balance report of the flight accurately represents the actual load and that the actual load does not exceed the

maximum allowable weight limits specified in the AFM for any phase of the flight.

The report may be prepared by the crew, another qualified person authorized by the company or by the operator of the aircraft.

Companies and operators may establish specific procedures with respect to preparing and retaining weight and balance documentation in order to meet regulatory requirements.

3.4.5 Computerized Systems

When a company or operator generates load data from a computerized weight and balance system, the integrity of the output data must be checked at regular intervals (preferably not greater than six months). The length of the intervals must be specified in the company operations manual.

There must be a means in place to identify the person inputting the data for the preparation of every load manifest. Moreover, the identity of that person must be verified and authenticated by the system and retained as required.

3.4.6 Segmented Weights

In practice, it was found that the use of standard passenger weights, regardless of aircraft size, increases the probability of overloading the aircraft when its passenger-carrying capacity decreases and vice versa. For example, when the standard passenger weight is used for an aircraft certificated for 12 passengers, like the Twin Otter, the statistical probability of overloading the aircraft is as high as 25%, whereas when it is used for large passenger aircraft, like the Boeing 747, this probability diminishes to 0.0014%.

Furthermore, a single weight cannot account for the weight differences between men and women or for variations in aircraft seating capacity. To minimize the probability of overloading the aircraft, an alternative to standard passenger weights, called segmented weights, was implemented. Segmented weights are based on aircraft seating capacity and account for weight differences between men and women as well as for summer and winter variations.

Segmented weights are designed to guarantee a 95% confidence level that the actual total weight of passengers will not exceed the total weight of passengers obtained by using segmented weights by more than one percent. This is the benchmark of segmented weights for accuracy and reliability.

3.4.6.1 Derivation of Segmented Weights

A specific methodology was used to calculate the precise values published in the segmented weight tables. TCCA's segmented weight tables are based on the Canadian Community Health Survey, Cycle 2.1 (2003), which obtained large-scale weight data by interviewing some 130 000 Canadians. In addition, standard deviations of 16.8 kg (37 lb) for males and 14.6 kg (32.2 lb) for females were applied to obtain a revised average weight for each sex. These weights were further modified to account for specific aircraft seating capacity ranges so as to be representative of the highest average weight amongst all sample sizes for that range. A constant value of 5.9 kg (13 lb) for carry-on baggage

was then added to the average adult (male/female) passenger weight and finally, two values were developed to account for seasonal variations in personal clothing—3.6 kg (8 lb) for summer clothing and 6.4 kg (14 lb) for winter clothing. See Table 3.2 for finalized weight values.

3.4.7 Computation of Passenger and Baggage Weights

To compute passenger weight, the following methods are used: actual weights, standard weights and segmented weights.

NOTE:

For aircraft with a passenger seating capacity of less than five, the use of actual weights provides the greatest accuracy in calculating the weight and balance of the aircraft, therefore the use of standard or segmented passenger weights is not recommended.

- (a) **Using Actual Weights**—In determining the actual weight, an air operator must weigh each passenger and must ensure that personal clothing and carry-on baggage are also weighed. The total of the person's weight, personal clothing and carry-on baggage would then be treated as the passenger's weight. Weighing should be conducted just before boarding (to minimize the chances of the passenger acquiring additional load just before boarding the aircraft); alternatively, the allowances for personal clothing and carry-on baggage can be added to a passenger's weight and the result can be used as the passenger's actual weight.

When a passenger refuses to be weighed, the air operator should ask the passenger to volunteer their weight (**volunteered weight**). If they refuse, the air operator should estimate the passenger's weight (**estimated weight**), ensuring in both cases that the allowances for personal clothing and carry-on baggage are included in the passenger's weight.

Personnel boarding passengers based on volunteered weights should be able to assess the validity of the disclosed weight. If a volunteered weight is deemed to be significantly inaccurate, personnel should use good judgment to make a reasonably accurate estimate. Similarly, estimating passenger weight must be done with a reasonable degree of accuracy. Due diligence should be exercised to ensure that passenger weights used to calculate the passenger and baggage load accurately reflect the actual weight to be carried on any given flight.

- (b) **Using Standard Weights**—The weight of each passenger is calculated using standard weights published by TCCA or established by the air operator. The standard weights include the standardized allowances for personal clothing and carry-on baggage. See Tables 3.1 and 3.3 for standard weights.
- (c) **Using Segmented Weights**—Segmented weights should be used only when actual weights, volunteered weights, and estimated weights are not available or cannot be implemented. Air operators are prohibited from using standard weights for aeroplanes operated under Subpart 703 of the CARs that also have a certificated passenger seating capacity of five

or more passengers. Instead, it is recommended that they use either actual weights or the segmented weights that are published by TCCA or established by the air operator.

When using the segmented weight table (Table 3.2), an air operator must follow these steps:

- (i) Step 1: Under the column titled Maximum Certificated Passenger Seating Capacity, select the row that represents the certificated seating capacity of the intended aircraft.
- (ii) Step 2: Under the column that represents the season, select winter or summer.
- (iii) Step 3: Depending on the aircraft capacity and seasons selected in steps 1 and 2, use the weight values identified in the intersecting cells for the weights of males and females. When changing the aircraft, steps 1 to 3 have to be repeated.
- (iv) Step 4: Multiply the individual male/female weight identified in step 3 by the number of male/female passengers on board, and the total of these weights will be the weight of the passenger load for that particular flight.

NOTES:

- 1. Actual weights should be used on any flight identified as carrying a significant number of passengers whose weight or number of carry-on baggage is deemed to be in excess of those specified in the segmented weights published by TCCA or established by the air operator.
- 2. The only circumstance under which the weight of carry-on baggage may not be added to the weight of each passenger is when no carry-on baggage is permitted on the flight.
- (d) **Weight of Children and Infants**—Each child should be weighed, or their weight should be included at the standard rate. Infants should be weighed with the accompanying adult. When an infant’s weight is over 10% of the adult passenger’s weight, the infant’s weight should be included separately at the rate of 13.6 kg (30 lbs) per infant. Infants occupying separate seats should be treated as children for the purpose of weight and balance calculation, and their weight should be included at the standard rate per child. See Table 3.3 for standard weights of children and infants.
- (e) **Checked Baggage and Cargo**—The air operator must use the actual weight of checked baggage and cargo.

Table 3.1—Standard Weights of Passengers Aged 12 Years or Older

Summer	—	Winter
93.4 kg or 206 lb	Males (12 years and up)	96.2 kg or 212 lb
78.1 kg or 172 lb	Females (12 years and up)	80.7 kg or 178 lb
93.4 kg or 206 lb	Gender X (12 years and up)	96.2 kg or 212 lb

Table 3.2—Segmented Weights of Passengers Aged 12 Years or Older in Pounds (lb)

Maximum Certificated Passenger Seating Capacity	Winter			Summer		
	Male	Female	Gender X	Male	Female	Gender X
1–4	Use actual weights, volunteered weights, or estimated weights.					
5	249	210	249	243	204	243
6–8	244	206	244	238	200	238
9–11	236	199	236	230	193	230
12–16	233	196	233	227	190	227
17–25	229	193	229	223	187	223

Table 3.3—Standard Weights of Children and Infants

Summer	—	Winter
34 kg or 75 lb	Children 2–11 years	34 kg or 75 lb
13.6 kg or 30 lb	*Infants 0 to less than 2 years	13.6 kg or 30 lb

3.4.8 Fuel and Oil Weights

Fuel and oil weights were obtained from the Canadian Government Standards Bureau specifications. It should be remembered that the capacity of tanks is often expressed in US gallons. The standard weights of fuel and oil are provided in Tables 3.4, 3.5 and 3.6.

NOTE:

The weights shown are for the maximum density at the various temperatures. The actual fuel weight for specific conditions can usually be obtained from the dealer supplying the fuel. Conversion factors for litres to imperial gallons and kilograms to pounds are found in GEN 1.7.1.

Table 3.4—Fuel Weight Based on Temperature

Temperature	-40°C			-20°C			0°C			15°C			30°C		
	lb per			lb per			lb per			lb per			lb per		
	litre	UK gal.	US gal.	litre	UK gal.	US gal.	litre	UK gal.	US gal.	litre	UK gal.	US gal.	litre	UK gal.	US gal.
Aviation Kerosene CAN 2-3, 23-M81 (JET A, JET A-1, JET A-2) and Arctic Diesel	1.93	8.80	7.32	1.90	8.65	7.19	1.87	8.50	7.09	1.85	8.39	7.00	1.83	8.27	6.91
Aviation Wide Cut Fuel CAN 2-3, 23-M80 (F-40 [JP4] and JET B)	1.85	8.38	6.99	1.82	8.24	6.88	1.79	8.11	6.78	1.77	8.01	6.68	1.74	7.92	6.60
Aviation Gasoline All Grades CAN 2-3, 25-M82 (AV GAS)	1.69	7.68	6.41	1.65	7.50	6.26	1.62	7.33	6.12	1.59	7.20	6.01	1.56	7.07	5.90

Table 3.5—Lubricating Oil Weight Based on Temperature

Temperature	-10°C			0°C			10°C			20°C			30°C		
	lb per			lb per			lb per			lb per			lb per		
	litre	UK gal.	US gal.	litre	UK gal.	US gal.	litre	UK gal.	US gal.	litre	UK gal.	US gal.	litre	UK gal.	US gal.
Piston Engine 65 Grade	1.98	8.98	7.46	1.97	8.92	7.46	1.95	8.85	7.38	1.94	8.78	7.33	1.92	8.71	7.28
120 Grade	2.01	9.10	7.59	1.99	9.03	7.54	1.97	8.96	7.46	1.96	8.88	7.41	1.94	8.82	7.35

Table 3.6—Turbine Engine Lubricating Oil Weight at a 15°C Temperature

Type of lubricating oil	lb/litre	lb/UK gal.	lb/US gal.
3cS	2.09	9.4	7.92
5cS	2.15	10.1	8.14

RAC

3.5 Flight Plans and Flight Itineraries

3.5.1 When Required

CAR 602.73 states that no pilot-in-command shall operate an aircraft in VFR flight unless a VFR flight plan or a VFR flight itinerary has been filed, except where the flight is conducted within 25 NM of the departure aerodrome.

No pilot-in-command shall operate an aircraft in IFR flight unless an IFR flight plan has been filed. A pilot-in-command may file an IFR flight itinerary instead of an IFR flight plan where:

- (a) the flight is conducted, in part or in whole, outside controlled airspace; or
- (b) facilities are inadequate to permit the communication of flight plan information to an ATC unit, an FSS or a CARS.

Notwithstanding any of the requirements mentioned above, pilots are required to file a flight plan when operating between Canada and a foreign state.

3.5.2 Filing a Flight Plan or Flight Itinerary (*Canadian Aviation Regulation [CAR] 602.75*)

602.75

- (1) A flight plan shall be filed with an air traffic control unit, a flight service station or a community aerodrome radio station.
- (2) A flight itinerary shall be filed with a responsible person, an air traffic control unit, a flight service station or a community aerodrome radio station.
- (3) A flight plan or flight itinerary, shall be filed by
 - (a) sending, delivering or otherwise communicating the flight plan or flight itinerary or the information contained therein; and
 - (b) receiving acknowledgement that the flight plan or flight itinerary or the information contained therein has been received.

A “responsible person” means an individual who has agreed with the person who has filed a flight itinerary to ensure that, if the aircraft is overdue, the following are notified in the manner prescribed in this Section:

- (a) an ATC unit, an FSS or a CARS; or
- (b) an RCC.

NOTES:

1. The notification requires the flight itinerary information.
2. The expression flight service station used in the regulation includes a FIC. Flight plan information should be filed with a FIC, where complete briefing information is available. An IFR flight plan should be submitted to the flight planning section of an ACC.

The timely filing of IFR flight plans or flight itineraries is essential to allow ATC personnel time to extract and record the relevant content, correlate these new data with available information on other traffic under control, coordinate as necessary, and determine how the flight may best be integrated with the other traffic.

Accordingly, in order to assist ATS in improving the service provided and to allow sufficient time for input into the ATS data processing system, pilots are encouraged to file IFR flight plans or flight itineraries as early as practicable, preferably at least 30 min prior to their proposed departure time. Pilots are expected to depart in accordance with the flight plan ETD. Some delay could be experienced if an IFR clearance is required less than 30 min after filing. It is also important that ATS be informed of the circumstances if commencement of an IFR flight is to be delayed. IFR flight itineraries are limited to one departure from and one entry into controlled airspace; multiple exits and entries into controlled airspace will not be accepted by ATS.

3.5.3 Flight Plan Requirements—Flights Between Canada and a Foreign State

A VFR or IFR flight plan must be filed prior to conducting any flight between Canada and a foreign state. If the flight is to any country other than the U.S., an ICAO flight plan must be filed. ATS must not accept flight itineraries, composite flight plans, or CVFR flight plans for flights between Canada and the U.S.

ADCUS notification is no longer accepted on flight plans for transborder flights departing from Canada to the U.S. or from the U.S. to Canada. Pilots are required to file a flight plan to an acceptable customs destination in the U.S. and are also required to contact U.S. Customs and Border Protection (CBP) to make customs arrangements prior to their flight. Failure to do so may subject the pilot to a penalty.

3.5.4 Opening a Visual Flight Rules (VFR) Flight Plan or Flight Itinerary

A VFR flight plan or flight itinerary should normally be opened with a TWR, an FSS, a FIC or a CARS upon departure to activate the alerting service. The pilot is responsible for extending or cancelling the flight plan or flight itinerary if the flight is delayed or cancelled. If an extension or cancellation is not received by the proposed departure time, the responsible ATS unit will activate the flight plan or flight itinerary, using the ETD as the actual time of departure (ATD).

3.6 Changes To The Information In A Flight Plan Or Flight Itinerary

Since control and alerting services are based primarily on information provided by the pilot, it is essential that modifications to flight plans and flight itineraries be communicated to an ATC unit, a FIC, a CARS or, as applicable, a responsible person concerned, as soon as practicable.

3.6.1 Visual Flight Rules (VFR) Flight Plan or Flight Itinerary

CAR 602.76(3) and (4) specify that a pilot “shall notify as soon as practicable an air traffic control unit, a flight service station, a community aerodrome radio station or the responsible person,” of any change to:

- (a) the route of flight,
- (b) the duration of the flight; or
- (c) the destination aerodrome.

3.6.2 Instrument Flight Rules (IFR) Flight Plan or Flight Itinerary

CAR 602.76(1) and (2) specify that a pilot shall notify as soon as practicable an air traffic control unit, a flight service station, a community aerodrome radio station or a responsible person, as the case may be, of any change to:

- (a) the cruising altitude or cruising flight level;
- (b) the route of flight;
- (c) the destination aerodrome;
- (d) when in controlled airspace:
 - (i) the true airspeed at the cruising altitude or cruising level where the change intended is 5% or more of the TAS specified in the IFR flight plan; or
 - (ii) the Mach number, where the change intended is 0.01 or more of the Mach number that has been included in the ATC clearance.

Where the flight is being conducted in controlled airspace, the pilot shall receive ATC clearance before making the intended change.

3.7 Composite Flight Plan Or Flight Itinerary—Visual Flight Rules (VFR) And Instrument Flight Rules (IFR)

A composite flight plan or flight itinerary may be filed that describes part(s) of the route as operating under VFR and part(s) of the route as operating under IFR. All rules governing VFR or IFR apply to that portion of the route of flight. A composite flight plan or flight itinerary shall not be filed for an aircraft that will enter airspace controlled by the FAA, including CDA delegated to the FAA, as composite data cannot be correctly processed between NAV CANADA and FAA systems.

A pilot who files IFR for the first part of a flight and VFR for the next part will be cleared by ATC to the point within controlled airspace at which the IFR part of the flight ends. A pilot who files VFR for the first part of a flight and IFR for the next part is expected to contact the appropriate ATC unit for clearance prior to approaching the point where the IFR portion of the flight commences. If direct contact with an ATC unit is not possible, the pilot may request ATC clearance through a FIC. It is important that the flight continue under VFR conditions until appropriate IFR clearance within controlled airspace is issued by ATC and acknowledged by the pilot.

3.8 Defence Visual Flight Rules (VFR) Flight Plans and Defence Flight Itineraries (*Canadian Aviation Regulation [CAR] 602.145*)

CAR 602.145 outlines the requirements when operating into or within the Air Defence Identification Zone (ADIZ). In order to ensure that the Air Traffic System (ATS) is aware that VFR flights will be operating into or within the ADIZ, ATS requires that pilots file a Defence Flight Plan or Flight Itinerary.

CAR 602.145 ADIZ states:

602.145 ADIZ

- (1) This Section applies in respect of aircraft before entering into and while operating within the ADIZ, the dimensions of which are specified in the *Designated Airspace Handbook*.
- (2) Every flight plan or flight itinerary required to be filed pursuant to this Section shall be filed with an air traffic control unit, a flight service station or a community aerodrome radio station.
- (3) The pilot-in-command of an aircraft whose point of departure within the ADIZ or last point of departure before entering the ADIZ has facilities for the transmission of flight plan or flight itinerary information shall:
 - (a) before takeoff, file a defence flight plan or defence flight itinerary;
 - (b) in the case of a VFR aircraft where the point of departure is outside the ADIZ,
 - (i) indicate in the flight plan or flight itinerary the estimated time and point of ADIZ entry, and
 - (ii) as soon as possible after takeoff, communicate by radio to an air traffic control unit, a flight service station or a community aerodrome radio station a position report of the aircraft's location, altitude, aerodrome of departure and estimated time and point of ADIZ entry; and
 - (c) in the case of a VFR aircraft where the point of departure is within the ADIZ, as soon as possible after takeoff, communicate by radio to an air traffic control unit, a flight service station or a community aerodrome radio station a position report of the aircraft's location, altitude and aerodrome of departure.
- (4) The pilot-in-command of an aircraft whose point of departure within the ADIZ or last point of departure before entering the ADIZ does not have facilities for the transmission of flight plan or flight itinerary information shall:
 - (a) as soon as possible after takeoff, file by radio communication a flight plan or flight itinerary; and
 - (b) in the case of a VFR aircraft, indicate in the flight plan or flight itinerary the estimated time and point of ADIZ entry, if applicable.
- (5) The pilot-in-command of a VFR aircraft shall revise the estimated time and point of ADIZ entry and inform an air traffic control unit, a flight service station or a community aerodrome radio station, when the aircraft is not expected

to arrive:

- (a) within plus or minus five minutes of the estimated time at:
 - (i) a reporting point,
 - (ii) the point of ADIZ entry, or
 - (iii) the point of destination within the ADIZ; or
- (b) within 20 nautical miles of:
 - (i) the estimated point of ADIZ entry, or
 - (ii) the centreline of the route of flight indicated in the flight plan or flight itinerary.

3.9 Intermediate Stops

Intermediate stops may not be included in a single instrument flight rules (IFR) flight plan. A single visual flight rules (VFR) flight plan or an IFR or VFR flight itinerary including one or more intermediate stops en route may be filed provided that:

- (a) for VFR flight plans, the stop will be of short duration (for purposes such as boarding passengers, and refuelling);
- (b) for IFR flight itineraries, the stop will be in uncontrolled airspace; and
- (c) each intermediate stop is indicated by repeating the name of the stopping point and its duration in the “Route” section of the flight plan or flight itinerary. Record the duration of the stopover in hours and minutes with four consecutive digits. Example: CYXU 0045 CYXU. You may include a phone number for the stopover in the “Other Information” section of the flight plan or flight itinerary, if available, as this may be useful in case of search and rescue (SAR).

When intermediate stops are planned, the “Estimated Elapsed Time” must be calculated as the total time to the final destination, including the duration of the intermediate stops. It should be noted that SAR action would only be initiated at the specified SAR time or, in the event that a SAR time is not indicated, 60 minutes for a flight plan and 24 hours for a flight itinerary after the estimated time of arrival (ETA) at the final destination. Pilots who wish to have SAR action based on every leg of a flight should file one flight plan or flight itinerary for each stop.

3.9.1 Consecutive Instrument Flight Rules (IFR) Flight Plans

Consecutive IFR flight plans may be filed at the initial point of departure providing the following points are adhered to:

- (a) initial point of departure and en route stops must be in Canada except that one flight plan will be accepted for a departure point within United States controlled airspace;
- (b) the sequence of stops will fall within one 24-hour period;
- (c) the flight planning unit must be provided with at least the following items of information for each stage of the flight:
 - (i) point of departure,
 - (ii) altitude,
 - (iii) route,
 - (iv) destination,

- (v) proposed time of departure,
- (vi) estimated elapsed time,
- (vii) alternate,
- (viii) fuel on board, and, if required,
 - (A) TAS,
 - (B) number of persons on board, and
 - (C) where an arrival report will be filed.

3.10 Cross-country Instrument Training Flights

A cross-country instrument training flight is one in which there are no intermediate stops and one or more instrument approaches are made en route. For example, an aircraft departs Airport A, completes a practice approach at Airport B, and either lands at destination Airport C or returns to land at Airport A.

The following apply:

- (a) A single flight plan is filed.
- (b) Those en route locations at which instrument approaches and overshoots are requested shall be listed in the “Other Information” portion of the flight plan form, together with the estimated period of time to carry out each approach. In addition, the total en route time should be included, including approaches and holds followed by the destination airport (e.g. REQ NDB RWY 32 AT B-15 MIN 0230A).
- (c) The estimated elapsed time (EET) of the flight plan form is NOT to include the estimated time to carry out approaches and holds at the en route locations.
- (d) ATC will normally clear the aircraft to final destination.
- (e) If it is not practicable to clear the aircraft to final destination or to assign an operationally suitable altitude with the initial clearance, a time or specific location for the aircraft to expect further clearance to the destination or to a higher altitude will be issued with the initial clearance.
- (f) When an en route approach clearance is requested, a missed approach clearance will be issued to the aircraft prior to the commencement of the approach.
- (g) If traffic does not permit an approach, holding instructions will be issued to the aircraft if requested by the pilot.

3.11 Closing a Flight Plan

In order to comply with CAR 602.77, an arrival report for a flight plan shall be submitted to an ATC unit, an FSS (or a FIC) or a CARS as soon as practicable after landing but not later than:

- (a) the SAR time specified in the flight plan; or
- (b) where no SAR time is specified in the flight plan, one hour after the last reported ETA.

A pilot who terminates a flight itinerary shall ensure that an arrival report is filed with an ATC unit, an FSS (or a FIC), a CARS or, where the flight itinerary was filed with a responsible person, the responsible person as soon as practicable after landing but not later than:

- (a) the SAR time specified in the flight itinerary; or
- (b) where no SAR time was specified in the flight itinerary, 24 hours after the last reported ETA.

A pilot who terminates an IFR flight at an aerodrome where there is an operating ATC unit, FSS or where RAAS is provided, is not required to file an arrival report unless requested to do so by the appropriate ATC unit or FSS.

When submitting an arrival report, the pilot should clearly indicate that he/she was operating on a flight plan or flight itinerary and wishes it to be closed. Failure to close a flight plan or flight itinerary will initiate SAR action. It should not be assumed that ATS personnel will automatically file arrival reports for VFR flights at locations served by control towers and FSSs or an RCO. Toll-free calls, as outlined in the CFS, may be made to an ATS facility for this purpose.

3.11.1 Arrival Report

CAR 602.78 specifies that the contents of an arrival report for a flight plan or flight itinerary, which are listed in the CFS, shall include:

- (a) the aircraft registration mark, flight number or radio call sign;
- (b) the type of flight plan or flight itinerary;
- (c) the departure aerodrome;
- (d) the arrival aerodrome, and
- (e) the date and time of arrival.

3.11.2 Closing of a Flight Plan or Flight Itinerary Prior to Landing

A pilot, who conducts a flight in respect of which a flight plan or flight itinerary has been filed with an ATC unit, FIC, FSS, or CARS, has the option of closing the flight plan or flight itinerary with any of these agencies prior to landing.

The closing of a flight plan or flight itinerary prior to landing is considered as filing an arrival report, and as such, it will result in the termination of all alerting services with respect to SAR notification.

When flying IFR in airspace under the jurisdiction of Canadian ATC, use of the phrase “Cancelling IFR” results in ATC discontinuing the provision of IFR separation, but it does not automatically close the flight plan or itinerary. Therefore, alerting service with regard to SAR notification is still active and is based on the information submitted in the original flight plan or itinerary. Because the pilot is now flying in accordance with VFR, the flight plan or itinerary must either be closed prior to landing, or an arrival report filed after landing, with an ATC unit, a FIC, a FSS or a CARS. When flying IFR in the U.S.A. or landing at a Canadian airport that underlies airspace delegated to the control of the FAA, use of the phrase “Cancelling IFR”

results in ATC discontinuing the provision of IFR separation and also closes the flight plan or itinerary. Therefore, alerting service with regard to SAR notification is also terminated, unless the pilot files and activates a VFR flight plan.

3.12 Fuel Requirements

The fuel requirements contained in this Section do not apply to gliders, balloons or ultra-light aeroplanes. (CAR 602.88)

In addition to VFR and IFR fuel requirements, every aircraft shall carry an amount of fuel that is sufficient to provide for

- (a) taxiing and foreseeable delays prior to takeoff;
- (b) meteorological conditions;
- (c) foreseeable air traffic routings and traffic delays;
- (d) landing at a suitable aerodrome in the event of loss of cabin pressurization or, in the case of a multi-engined aircraft, failure of any engine, at the most critical point during the flight; and
- (e) any other foreseeable conditions that could delay the landing of the aircraft.

3.12.1 Visual Flight Rules (VFR) Flight

An aircraft operated in VFR flight shall carry an amount of fuel that is sufficient to allow the aircraft

- (a) in the case of an aircraft other than a helicopter,
 - (i) when operated during the day, to fly to the destination aerodrome and then to fly for 30 minutes at normal cruising speed, or
 - (ii) when operated at night, to fly to the destination aerodrome and then to fly for 45 minutes at normal cruising speed, or
- (b) in the case of a helicopter, to fly to the destination aerodrome and then to fly for 20 min. at normal cruising speed.

3.12.2 Instrument Flight Rules (IFR) Flight

An aircraft operated in IFR flight shall carry an amount of fuel that is sufficient to allow the aircraft

- (a) in the case of a propeller-driven aeroplane,
 - (i) where an alternate aerodrome is specified in the flight plan or flight itinerary, to fly to and execute an approach and a missed approach at the destination aerodrome, to fly to and land at the alternate aerodrome, and then to fly for a period of 45 minutes, or
 - (ii) where an alternate aerodrome is not specified in the flight plan or flight itinerary, to fly to and execute an approach and a missed approach at the destination aerodrome and then to fly for a period of 45 minutes; or
- (b) in the case of a turbojet powered aeroplane or a helicopter,
 - (i) where an alternate aerodrome is specified in the flight plan or flight itinerary, to fly to and execute an approach and a missed approach at the destination aerodrome, to fly to and land at the alternate

aerodrome, and then to fly for a period of 30 minutes, or

- (ii) where an alternate aerodrome is not specified in the flight plan or flight itinerary, to fly to and execute an approach and a missed approach at the destination aerodrome and then to fly for a period of 30 minutes.

3.13 Requirements for Alternate Aerodrome — Instrument Flight Rules (IFR) Flight

Except as otherwise authorized by the Minister in an air operator certificate (AOC) or in a private operator certificate, no pilot-in-command shall operate an aircraft in IFR flight unless the IFR flight plan or IFR flight itinerary that has been filed for the flight includes an alternate aerodrome having a landing area suitable for use by that aircraft. No pilot-in-command of an aircraft shall include an alternate aerodrome in an IFR flight plan or IFR flight itinerary unless available weather information indicates that the ceiling and ground visibility at the alternate aerodrome will, at the expected time of arrival, be at or above the alternate aerodrome weather minima criteria specified in the CAP. (CARs 602.122 and 602.123)

Aerodrome forecasts (TAF) that contain the terms BECMG, TEMPO or PROB may be used to determine the weather suitability of an aerodrome as an alternate, provided that:

- (a) where conditions are forecast to improve, the forecast BECMG condition shall be considered to be applicable as of the end of the BECMG time period, and these conditions shall not be below the published alternate minima requirements for that aerodrome;
- (b) where conditions are forecast to deteriorate, the forecast BECMG condition shall be considered to be applicable as of the start of the BECMG time period, and these conditions shall not be below the published alternate minima requirements for that aerodrome;
- (c) the forecast TEMPO condition shall not be below the published alternate minima requirements for that aerodrome; and
- (d) the forecast PROB condition shall not be below the appropriate landing minima for that aerodrome.

3.13.1 Alternate Aerodrome Weather Minima Requirements

Authorized weather minima for alternate aerodromes are to be determined using the information presented in the tables below. The “Alternate Weather Minima Requirements” table presented in the CAP GEN (reproduced below) applies to all approach charts, except where use as an alternate is not authorized on the chart. The minima derived for an alternate aerodrome shall be consistent with aircraft performance, navigation-equipment limitations, functioning NAVAIDs, type of weather forecast and runway to be used.

Pilots may take credit for RNAV approaches at alternate aerodromes in accordance with the criteria outlined in the “Alternate Aerodrome Weather Minima Requirements” section of the CAP GEN.

Table 3.7—Alternate Aerodrome Weather Minima Requirements

FACILITIES AVAILABLE AT SUITABLE ALTERNATE	WEATHER REQUIREMENTS
TWO OR MORE USABLE PRECISION APPROACHES, each providing straight-in minima to separate suitable runways	400-1 or 200-1/2 above lowest usable HAT and visibility, whichever is greater.
ONE USABLE PRECISION APPROACH	600-2* or 300-1 above the lowest usable HAT and visibility, whichever is greater.
NON-PRECISION ONLY AVAILABLE	800-2* or 300-1 above the lowest usable HAT/HAA and visibility, whichever is greater.
NO IFR APPROACH AVAILABLE	Forecast weather must be no lower than 500 ft above a minimum IFR altitude that will permit a VFR approach and landing.
FOR HELICOPTERS, where instrument approach procedures are available	Ceiling 200 ft above the minima for the approach to be flown, and visibility at least 1 SM, but never less than the minimum visibility for the approach to be flown.

*600-2 and 800-2, as appropriate, are considered to be STANDARD ALTERNATE MINIMA.

Should the selected alternate weather requirements meet the standard minima, then the following minima are also authorized:

Table 3.8—Other Authorized Minima

STANDARD ALTERNATE MINIMA		IF STANDARD IS APPLICABLE, THEN THE FOLLOWING MINIMA ARE ALSO AUTHORIZED	
CEILING	VISIBILITY	CEILING	VISIBILITY
600	2	700 800	1 1/2 1
800	2	900 1000	1 1/2 1

NOTES:

1. These requirements are predicated upon the aerodrome having a TAF available.
2. Aerodromes served with an AERODROME ADVISORY forecast may qualify as an alternate, provided the forecast weather is no lower than 500 ft above the lowest usable HAT/HAA and the visibility is not less than 3 mi.
3. Aerodromes served with a GRAPHIC AREA FORECAST (GFA) may qualify as an alternate, provided the forecast weather contains:
 - (a) no cloud lower than 1 000 ft above the lowest usable HAT/HAA;
 - (b) no cumulonimbus; and
 - (c) a visibility that is not less than 3 mi.

4. Ceiling minima are calculated by reference to the procedure HAA or HAT. Ceiling values in aviation forecasts are established in 100–ft increments. Up to 20 ft, use the lower 100–ft increment; above 20 ft, use the next higher 100–ft increment:
Examples:
HAA 620 ft = ceiling value of 600 ft;
HAA 621 ft = ceiling value of 700 ft;
HAT 420 ft = ceiling value of 400 ft;
HAT 421 ft = ceiling value of 500 ft.
5. Calculated visibilities should not exceed 3 mi.

CAUTION:

All heights specified in a GFA are ASL, unless otherwise indicated.

The emphasis of these criteria is placed upon the availability of the lowest usable landing HAT/HAA and visibility for an aerodrome. In determining the lowest usable landing HAT/HAA and visibility, the pilot should consider:

- (a) the operational availability of the ground navigational equipment by consulting NOTAM;
- (b) the compatibility of the aircraft equipment with the ground navigational equipment;
- (c) the forecast surface wind conditions could dictate the landing runway and associated approach minima;
- (d) the operational applicability of terms BECMG, TEMPO and PROB within the forecast;
- (e) all heights mentioned within a GFA are ASL heights, unless otherwise indicated, and the terrain elevation must be applied in order to determine the lowest forecast ceiling at a particular location; and
- (f) alternate minima values determined from a previous flight operation may not be applicable to a subsequent flight operation.

3.14 Completion of Canadian Flight Plans and Flight Itineraries and International Civil Aviation Organization (ICAO) Flight Plans

3.14.1 General

The flight plan form is to be used for Canadian flight plans or flight itineraries and ICAO flight plans. Completion of the form is simply a matter of inserting the requested information in the appropriate boxes. The white boxes relate to required information for Canadian flight plans and for flight itineraries and for ICAO flight plans. The shaded boxes indicate the information which is applicable only to Canadian flight plans and flight itineraries.

NOTE:

A Canadian flight plan is used for flights from Canada to the United States.

3.14.2 Canadian

A Canadian flight plan or flight itinerary shall contain such information as is specified in the CFS, including:

- (a) aircraft identification
- (b) flight rules
- (c) type of flight
- (d) number of aircraft (if more than one)
- (e) type of aircraft
- (f) wake turbulence category
- (g) equipment
- (h) departure aerodrome
- (i) time of departure (UTC)—proposed/actual
- (j) cruising speed
- (k) altitude/level
- (l) route
- (m) destination aerodrome
- (n) EET en-route
- (o) SAR time*
- (p) destination alternate aerodrome
- (q) endurance (flight time in hours and minutes)
- (r) total number of persons on board
- (s) type of ELT*
- (t) survival equipment (type, jackets, dinghies)
- (u) aircraft colour and markings
- (v) remarks (regarding other survival equipment)
- (w) arrival report—where it will be filed*
- (x) name and number or address of person or company to be notified if SAR action is initiated*
- (y) pilot’s name
- (z) pilot’s licence number (Canadian pilot licence only)*

* Not required for an ICAO flight plan

3.14.3 International Civil Aviation Organization (ICAO)

Flight plans for international flights originating in, or entering, Canada shall be filed in the ICAO format, as specified in ICAO Doc 4444—*Procedures for Air Navigation Services—Air Traffic Management*.

For the purpose of flight planning, flights between Canada and the continental United States are not classed as “international flights”.

3.14.4 Instructions for Completing the Form

3.14.4.1 General

Adhere closely to the prescribed formats and manner of specifying data.

Commence inserting data in the first space provided. Where excess space is available, leave unused spaces blank.

All times should be indicated in UTC, using four digits.

Indicate all EETs using four digits (hours and minutes) for flight plans.

NOTE:

Because EETs on a flight itinerary may include days as well as hours and minutes, insert the EET using six digits, if required.

The shaded area preceding Item 3 is to be completed by ATS and COM services, unless the responsibility for originating flight plan messages has been delegated.

NOTE:

The term “aerodrome,” where used in the flight plan, is intended to also cover sites other than aerodromes that may be used by certain types of aircraft, e.g. helicopters or balloons.

3.14.4.2 Instructions for Insertion of ATS Data

Complete Items 7 to 18 as indicated hereunder.

Complete Item 19 as well to facilitate alerting of SAR services.

NOTE:

Item numbers on the form are not consecutive as they correspond to Field Type numbers in ATS messages.

Use location indicators listed in Canadian AIPs (defined in CAR 300.01), in ICAO Doc 7910—*Location Indicators*, and in FAA Order 7350.7—*Location Identifiers*.

3.15 Contents of a Flight Plan and Flight Itinerary

3.15.1 Item 7: Aircraft Identification (not exceeding seven alphanumeric characters and without hyphens or symbols)

Canadian:

Normally, this consists of the aircraft registration letters or the company designator followed by the flight number.

Examples:

- (a) Aircraft registration: N123B, CGABC, 4XGUC
- (b) Operating agency and flight number: ACA123, KLM672
- (c) Tactical call sign: BRUNO12, SWIFT45, RED1

ICAO:

- (a) the ICAO designator for the aircraft operating agency followed by the flight identification (e.g. KLM511, NGA213, JTR25) when in radiotelephony the call sign to be used by the aircraft will consist of the ICAO telephony designator for the operating agency followed by the flight identification (e.g. KLM511, NIGERIA213, JESTER25); OR
- (b) the nationality or common mark and registration mark of the aircraft (e.g. E1AKO, 4XBCD, N2567GA), when:
 - (i) in radiotelephony, the call sign to be used by the aircraft will consist of this identification alone (e.g. CGAJS), or will be preceded by the ICAO telephony designator for the aircraft operating agency (e.g. BLIZZARD CGAJS); or
 - (ii) the aircraft is not equipped with radio.

NOTES:

1. Standards for nationality, common and registration marks to be used are contained in ICAO Annex 7, Chapter 2.
2. Provisions for the use of radiotelephony call signs are contained in ICAO Annex 10, Volume II, Chapter 5. ICAO designators and telephony designators for aircraft operating agencies are contained in ICAO Doc 8585—*Designators for Aircraft Operating Agencies, Aeronautical Authorities and Services*.

3.15.2 Item 8: Flight Rules and Type of Flight

3.15.2.1 Flight Rules (one character) (Canadian and ICAO)

INSERT one of the following letters to denote the category of flight rules with which the pilot intends to comply:

- I if it is intended that the entire flight will be operated under IFR;
- V if it is intended that the entire flight will be operated under VFR;
- Y if the flight initially will be operated under IFR, followed by one or more subsequent changes of flight rules; or
- Z if the flight initially will be operated under VFR, followed by one or more subsequent changes of flight rules.

If “Y” or “Z” is filed, specify, in the Route section of the flight plan (Item 15), the point(s) where a change in flight rules is planned. Similarly, where there is more than one change in the type of flight rules, the code to be used is to reflect the first rule, i.e. use “Z” for VFR/IFR/VFR.

3.15.2.2 Type of Flight (up to two characters, as applicable)

INSERT up to two of the following letters to denote the type of flight when so required by the appropriate ATS authority:

First character (Canadian only, as applicable):

- C for controlled VFR;
- D for defence flight plan;
- E for defence flight itinerary;
- F for flight itinerary.

Second character (ICAO, as applicable):

- S for scheduled air service;
- N for non-scheduled air transport operation;
- G for general aviation;
- M for military;
- X for other than the preceding categories.

Specify the status of a flight following the indicator “STS” in Item 18, or when necessary to denote other reasons for specific handling by ATS, indicate the reason following the indicator “RMK/” in Item 18.

3.15.3 Item 9: Number and Type of Aircraft and Wake Turbulence Category

3.15.3.1 Number of Aircraft (one or two characters)

INSERT the number of aircraft, if more than one.

3.15.3.2 Type of Aircraft (two to four characters)

INSERT the appropriate ICAO aircraft type designator. If no such designator has been assigned, or in the case of formation flights comprising more than one type, insert “ZZZZ” and specify in Item 18 the number(s) and type(s) of aircraft preceded by “TYP”.

3.15.3.3 International Civil Aviation Organization (ICAO) Wake Turbulence Category (one character)

INSERT one of the following letters to indicate the wake turbulence category of the aircraft:

- H (HEAVY) to indicate an aircraft type with a maximum certificated take-off mass of 136 000 kg (300 000 lbs) or more.
- M (MEDIUM) to indicate an aircraft type with a maximum certificated take-off mass of less than 136 000 kg (300 000 lbs) but more than 7 000 kg (15 500 lbs).
- L (LIGHT) to indicate an aircraft type with a maximum certificated take-off mass of 7 000 kg (15 500 lbs) or less.

3.15.4 Item 10: Equipment (Canadian and International Civil Aviation Organization (ICAO))

Capabilities comprise the following elements:

- (a) presence of relevant serviceable equipment on board the aircraft;
- (b) equipment and capabilities commensurate with flight crew qualifications; and
- (c) where applicable, authorization from the appropriate authority.

The COM, NAV, approach aid and SUR equipment on board and its serviceability must be inserted by adding the appropriate suffixes. The first suffixes will denote the COM, NAV and approach aid equipment, followed by an oblique stroke, and another suffix will denote the SUR equipment.

3.15.4.1 Radio Communication, Navigation and Approach Aid Equipment and Capabilities

INSERT one letter as follows:

- “N” if no COM, NAV or approach aid equipment for the route to be flown is carried, or the equipment is unserviceable; OR
- “S” if standard COM, NAV and approach aid equipment for the route to be flown is carried and available (see NOTE 1)

Information on navigation capability is provided to ATC for clearance and routing purposes.

AND/OR INSERT one or more of the following letters to indicate the serviceable COM, NAV and approach aid equipment and capabilities available.

Table 3.9—Alphanumeric Characters to Be Indicated in Flight Plan Item 10: Equipment

A	GBAS landing system	K	MLS
B	LPV (APV with SBAS)	L	ILS
C	LORAN C	M1	ATC SATVOICE (INMARSAT)
D	DME	M2	ATC SATVOICE (MTSAT)
E1	FMC WPR ACARS	M3	ATC SATVOICE (Iridium)
E2	D-FIS ACARS	O	VOR
E3	PDC ACARS	P1	CPDLC RCP 400
F	ADF	P2	CPDLC RCP 240
G	GNSS (see NOTE 2)	P3	SATVOICE RCP 400
H	HF RTF	P4–P9	Reserved for RCP
I	Inertial Navigation	R	PBN approved (see NOTE 5)
J1	CPDLC ATN VDL Mode 2 (see NOTE 3)	T	TACAN
J2	CPDLC FANS 1/A HF DL	U	UHF RTF
J3	CPDLC FANS 1/A VDL mode A	V	VHF RTF
J4	CPDLC FANS 1/A VDL mode 2	W	RVSM approved
J5	CPDLC FANS 1/A SATCOM (INMARSAT)	X	MNPS approved
J6	CPDLC FANS 1/A SATCOM (MTSAT)	Y	VHF with 8.33 kHz channel spacing capability
J7	CPDLC FANS 1/A SATCOM (Iridium)	Z	Other equipment carried or other capabilities (see NOTE 6)

Any alphanumeric characters not indicated above are reserved.

NOTES:

1. If the letter “S” is used, standard equipment is considered to be VHF RTF, VOR and ILS, unless another combination is prescribed by the appropriate ATS authority.
2. ICAO: If the letter “G” is used, the types of external GNSS augmentation, if any, are specified in Item 18 following the indicator “NAV/” and separated by a space.
3. Canadian: When using the letter “G” on an IFR flight plan, the GNSS receiver must be approved in accordance with the requirements specified in *AIP Canada* ENR 4.3. IFR-certified receivers are not mandatory for VFR flights. Pilots are encouraged to use the letter “G” on VFR flight plans when using any type of GNSS to assist VFR navigation.

4. See *RTCA/EUROCAE Interoperability Requirements Standard For ATN Baseline 1* (ATN B1 INTEROP Standard—DO-280B/ED-110B) for data link services, ATC clearance and information, ATC communications management, and ATC microphone check.
5. If the letter “R” is used, the performance-based navigation levels that can be met are specified in Item 18 following the indicator “PBN/”. Guidance material on the application of performance-based navigation to a specific route segment, route or area is contained in the *Performance-Based Navigation Manual* (ICAO Doc 9613).
6. If the letter “Z” is used, specify in Item 18 the other equipment carried, or other capabilities, preceded by “COM/”, “NAV/” and/or “DAT/”, as appropriate.

3.15.4.2 Surveillance Equipment and Capabilities

INSERT “N” if no surveillance equipment for the route to be flown is carried, or the equipment is unserviceable, OR INSERT one or more of the following descriptors, to a maximum of 20 characters, to describe the serviceable surveillance equipment and/or capabilities on board:

SSR Modes A and C

A Transponder—Mode A (four digits—4096 codes);

C Transponder—Mode A (four digits—4096 codes) and Mode C

SSR Mode S

E Transponder—Mode S, including aircraft identification, pressure-altitude and extended squitter (ADS-B) capability;

H Transponder—Mode S, including aircraft identification, pressure-altitude and enhanced surveillance capability;

I Transponder—Mode S, including aircraft identification, but no pressure-altitude capability;

L Transponder—Mode S, including aircraft identification, pressure-altitude, extended squitter (ADS-B) and enhanced surveillance capability;

P Transponder—Mode S, including pressure-altitude transmission, but no aircraft identification capability;

S Transponder—Mode S, including both pressure-altitude and aircraft identification capability;

X Transponder—Mode S with neither aircraft identification nor pressure-altitude capability.

NOTE:

Enhanced surveillance capability is the ability of the aircraft to down-link aircraft-derived data via a Mode S transponder.

ADS-B

B1 ADS-B with dedicated 1090 MHz ADS-B “out” capability;

B2 ADS-B with dedicated 1090 MHz ADS-B “out” and “in” capability;

U1 ADS-B “out” capability using UAT;

U2 ADS-B “out” and “in” capability using UAT;

V1 ADS-B “out” capability using VDL Mode 4;

V2 ADS-B “out” and “in” capability using VDL Mode 4.

In addition to the ADS-B alphanumeric characters listed above, aircraft equipped in accordance with the Canadian ADS-B mandate will also need to include CANMANDATE in “Other Information” following the indicator SUR/.

Example: SUR/CANMANDATE

ADS-C

D1 ADS-C with FANS 1/A capabilities;

G1 ADS-C with ATN capabilities.

Alphanumeric characters not indicated above are reserved.

Example:

ADE3RV/HB2U2V2G1

NOTE:

Additional surveillance application should be listed in Item 18 following the indicator “SUR/.”

3.15.5 Item 13: Departure Aerodrome and Time

3.15.5.1 Departure Aerodrome (maximum four characters)

ICAO:

INSERT the ICAO four-letter location indicator of the departure aerodrome as specified in ICAO Doc 7910—*Location Indicators*;

OR

Canadian:

INSERT the four-character location indicator of the departure aerodrome; OR

Canadian and ICAO:

If no location indicator has been assigned:

INSERT “ZZZZ” and specify in Item 18 the name and location of the aerodrome preceded by “DEP/”; OR

INSERT the first point of the route or the marker radio beacon preceded by “DEP/”, if the aircraft has not taken off from the aerodrome.

3.15.5.2 Time (maximum four characters)

Indicate the hour and minutes in UTC.

NOTE:

Pilots may file a flight plan or flight itinerary up to 24 hr in advance of the departure time.

3.15.6 Item 15: Cruising Speed, Altitude/Level and Route

Canadian:

NOTES:

1. On designated airways and air routes, IFR flights may be operated at the published MEA/MOCA, except that in winter, when air temperatures may be much lower than those of the ICAO Standard Atmosphere (ISA), aircraft should be operated at an altitude which is at least 1 000 ft higher than the published MEA/MOCA.
2. Mandatory IFR routes, published in the CFS—Planning section, have been established to aid in the efficient and orderly management of air traffic between selected aerodromes. Pilots are required to file these routes.

Canadian and ICAO:

INSERT

- the first cruising speed as described in (a),
- the first cruising level as described in (b), and
- the route description as described in (c).

(a) *Cruising speed* (maximum five characters)

INSERT the true airspeed for the first or the whole cruising portion of the flight, in terms of:

- (i) Kilometres per hour (ICAO only), expressed as “K” followed by four figures (e.g. K0830); OR
- (ii) Knots, expressed as “N” followed by four figures (e.g. N0485); OR
- (iii) True Mach number, when so prescribed by the appropriate ATS authority, to the nearest hundredth of unit Mach, expressed as “M ” followed by three figures (e.g. M082).

(b) *Cruising level* (maximum five characters)

INSERT the planned cruising level for the first or the whole portion of the route to be flown, in terms of:

- (i) Flight level, expressed as “F” followed by three figures (e.g. F085, F330); OR
- (ii) Standard metric level in tens of metres (ICAO only), expressed as “S” followed by four figures (e.g. S1130), when so prescribed by the appropriate ATS authorities; OR
- (iii) Altitude in hundreds of feet, expressed as “A” followed by three figures (e.g. A045, A100); OR
- (iv) Altitude in tens of metres (ICAO only), expressed as “M” followed by four figures (e.g. M0840); OR
- (v) For uncontrolled VFR flights, the letters “VFR” (ICAO only).

(c) *Route* (including changes of speed, level and/or flight rules)

3.15.6.1 Flights Along Designated Air Traffic Service (ATS) Routes:

INSERT if the departure aerodrome is located on, or connected to, the ATS route:

- (a) the designator of the first ATS route (e.g. if the departure aerodrome is Carp: T614 TUKIR, etc.); OR
- (b) if the departure aerodrome is not located on, or connected to, the ATS route:
 - (i) (ICAO only) the letters “DCT”, followed by the joining point of the first ATS route, followed by the designator of the ATS route (e.g. if the departure aerodrome is Ottawa: DCT IKLAX T634, etc.);
 - (ii) (Canadian only) the joining point of the first ATS route, followed by the designator of the ATS route (e.g. if the departure aerodrome is Ottawa: YOW T616, etc.).

INSERT each point at which a change of speed or level is planned to commence, or a change of ATS route, or a change of flight rules is planned (e.g. AGLUK/N0200A170 IFR).

NOTE:

When a transition is planned between a lower and an upper ATS route and the routes are oriented in the same direction, the point of transition need not be inserted.

FOLLOWED IN EACH CASE BY

- (a) the designator of the next ATS route segment, even if it is the same as the previous one (e.g. if the departure aerodrome is Québec: DICEN T680 LETAK T616, etc.); OR
- (b) if the flight to the next point is outside a designated route:
 - (i) (ICAO only) the letters “DCT”, unless both points are defined by geographical coordinates (e.g. if the departure aerodrome is Québec: DCT YQB DCT FLEUR DCT YYY, etc.);
 - (ii) (Canadian only) the next point (e.g. if the departure aerodrome is Québec: YQB FLEUR YYY etc.). The absence of “DCT” between points on a Canadian flight plan or flight itinerary indicates direct flight.

3.15.6.2 Flights Outside Designated Air Traffic Service (ATS) Routes:

ICAO:

INSERT points normally not more than 30 min flying time or 370 km (200 NM) apart, including each point at which a change of speed or level, a change of track, or a change of flight rules is planned; OR

When required by appropriate ATS authority(ies),

DEFINE the track of flights operating predominantly in an east-west direction between 70°N and 70°S by reference to significant points formed by the intersections of half or whole degrees of latitude with meridians spaced at intervals of 10° of longitude. For flights operating in areas outside those latitudes, the tracks shall be defined by significant points formed by the intersection of parallels of latitude with meridians normally

spaced at 20° of longitude. The distance between significant points shall, as far as possible, not exceed one hour’s flight time. Additional significant points shall be established as deemed necessary.

For flights operating predominantly in a north-south direction, define tracks by reference to significant points formed by the intersection of whole degrees of longitude with specified parallels of latitude which are spaced at 5°.

INSERT “DCT” between successive points unless both points are defined by geographical coordinates or by bearing and distance.

Canadian:

INSERT points at which a change of speed or level, a change of track, or a change of flight rules is planned. Absence of “DCT” between points on a Canadian flight plan or itinerary indicates direct flight; OR

When required by appropriate ATS authority(ies),

Canadian and ICAO:

USE the conventions in (1) to (5), below, and SEPARATE each sub-item by a space.

- (a) **ATS route (two to seven characters):** The coded designator assigned to the route or route segment including, where appropriate, the coded designator assigned to the standard departure or arrival route (e.g. BCN1, B1, R14, UB10, KODAP2A).

NOTE:

Provisions for the application of route designators are contained in ICAO Annex 11, Appendix 1.

- (b) **Significant point (two to eleven characters):** The coded designator (two to five characters) assigned to the point (e.g. LN, MAY, HADDY), OR

If no coded designator has been assigned, one of the following ways:

- (i) Degrees only (seven characters): Two figures describing latitude in degrees, followed by “N” (North) or “S” (South), followed by three figures describing longitude in degrees, followed by “E” (East) or “W” (West). Make up the correct number of figures, where necessary, by insertion of zeros, e.g. 46N078W.
- (ii) Degrees and minutes (11 characters): Four figures describing latitude in degrees, and tens and units of minutes followed by “N” (North) or “S” (South), followed by five figures describing longitude in degrees and tens and units of minutes, followed by “E” (East) or “W” (West). Make up the correct number of figures, where necessary, by insertion of zeros, e.g. 4620N07805W.
- (iii) Bearing and distance from a significant point: The identification of the significant point followed by the bearing from the point in the form of three figures giving degrees magnetic followed by the distance

from the point in the form of three figures expressing nautical miles. In areas of high latitude where it is determined by the appropriate authority that reference to degrees magnetic is impractical, degrees true may be used. Make up the correct number of figures, where necessary, by insertion of zeros, e.g. a point 180° magnetic at a distance of 40 NM from VOR “DUB” should be expressed as DUB180040.

- (c) **Change of speed or level (maximum 21 characters):** The point at which a change of speed (5 percent TAS or 0.01 Mach or more) or a change of level is planned to commence, expressed exactly as in (2), above, followed by an oblique stroke and both the cruising speed and the cruising level, expressed exactly as in (a) and (b), above, without a space between them, even when only one of these quantities will be changed.

Examples:

LN/N0284A045
 MAY/N0305F180
 HADDY/N0420F330
 4602N07805W/N0500F350
 46N078W/M082F330
 DUB180040/N0350M0840

- (d) **Change of flight rules (maximum three characters):** The point at which the change of flight rules is planned, expressed exactly as in (2) or (3), above, as appropriate, followed by a space and one of the following:
 - (i) VFR if from IFR to VFR
 - (ii) IFR if from VFR to IFR

Examples:

LN VFR
 LN/N0284A050 IFR

- (e) **Cruise climb (maximum 28 characters):** The letter “C” followed by an oblique stroke; THEN the point at which cruise climb is planned to start, expressed exactly as in (2), above, followed by an oblique stroke; THEN the speed to be maintained during cruise climb, expressed exactly as in (a), above, followed by the two levels defining the layer to be occupied during cruise climb, each level expressed exactly as in (b), above, or the level above which cruise climb is planned followed by the letters “PLUS”, without a space between them.

Examples:

C/48N050W/M082F290F350
 C/48N050W/M082F290PLUS
 C/52N050W/M220F580F620

3.15.7 Item 16: Destination Aerodrome, Total Estimated Elapse Time (EET), Search And Rescue (SAR) Time (for flights in Canada only) and Destination Alternate Aerodrome(s)

3.15.7.1 Destination Aerodrome and Total Estimated Elapse Time (EET) (maximum 10 characters)

ICAO:

INSERT the ICAO four-letter location indicator of the destination aerodrome as specified in ICAO Doc 7910—*Location Indicators*; OR

Canadian:

INSERT the four-character location indicator of the destination aerodrome; OR

NOTE:

In the case of a Canadian flight itinerary, as applicable, the EET may also include the number of days. The total duration of the flight itinerary shall not exceed 30 days.

Canadian and ICAO:

If no location indicator has been assigned,

INSERT “ZZZZ” and specify in Item 18 the name and location of the aerodrome, preceded by “DEST/”.

THEN, without a space, INSERT the total EET.

NOTE:

For a flight plan received from an aircraft in flight, the total EET is the estimated time from the first point of the route to which the flight plan applies to the termination point of the flight plan.

INSERT SAR time (four digits) (maximum of 24 hr)

3.15.7.2 Destination Alternate Aerodrome(s)

ICAO:

INSERT the ICAO four-letter location indicator(s) of not more than two destination alternate aerodromes, as specified in ICAO Doc 7910—*Location Indicators*, separated by a space; OR

Canadian:

INSERT the four-character location indicator of not more than two destination alternate aerodromes, separated by a space; OR

Canadian and ICAO:

If no location indicator has been assigned to the destination alternate aerodrome(s),

INSERT “ZZZZ” and specify in Item 18 the name and location of the destination alternate aerodrome(s), preceded by “ALTN/”.

NOTES:

1. If departure alternate required insert ZZZZ for second alternate aerodrome and SPECIFY in Item 18 the departure alternate, i.e.: DEP ALTN/CYOW.
2. No alternate is required on a VFR flight plan or itinerary.

3.15.8 Item 18: Other Information

NOTE:

Use of indicators not included under this item may result in data being rejected, processed incorrectly or lost.

Hyphens or oblique strokes should only be used as prescribed below.

INSERT “0” (zero) if no other information; OR

Any other necessary information in the sequence shown hereunder, in the form of the appropriate indicator selected from those defined hereunder, followed by an oblique stroke and the information to be recorded.

STS/ Reason for special handling by ATS, e.g. a SAR mission, as follows:

ALTRV: for a flight operated in accordance with an altitude reservation;

ATFMX: for a flight approved for exemption from ATFM measures by the appropriate ATS authority;

FFR: for fire-fighting;

FLTCK: for a flight check for calibration of NAVAIDs;

HAZMAT: for a flight carrying hazardous material;

HEAD: for a flight with Head of State status;

HOSP: for a medical flight declared by medical authorities;

HUM: for a flight operating on a humanitarian mission;

MARSA: for a flight for which a military entity assumes responsibility for separation of military aircraft;

MEDEVAC: for a life critical medical emergency evacuation;

NONRVSM: for a non-RVSM capable flight intending to operate in RVSM airspace;

SAR: for a flight engaged in a search and rescue mission; and

STATE: for a flight engaged in military, customs or police services.

Other reasons for special handling by ATS shall be denoted under the designator “RMK/.”

PBN/ Indication of RNAV and/or RNP capabilities: Include as many of the descriptors below as possible that apply to the flight, up to a maximum of eight entries, i.e. no more than 16 characters.

Table 3.10—RNAV Specifications to Be Indicated in Flight Plan Item 18: Other Information

A1	RNAV 10 (RNP 10)
B1	RNAV 5 all permitted sensors
B2	RNAV 5 GNSS
B3	RNAV 5 DME/DME
B4	RNAV 5 VOR/DME
B5	RNAV 5 INS or IRS
B6	RNAV 5 LORAN C
C1	RNAV 2 all permitted sensors
C2	RNAV 2 GNSS
C3	RNAV 2 DME/DME
C4	RNAV 2 DME/DME/IRU
D1	RNAV 1 all permitted sensors
D2	RNAV 1 GNSS
D3	RNAV 1 DME/DME
D4	RNAV 1 DME/DME/IRU

Table 3.11—RNP Specifications to Be Indicated in Flight Plan Item 18: Other Information

L1	RNP 4
O1	Basic RNP 1 all permitted sensors
O2	Basic RNP 1 GNSS
O3	Basic RNP 1 DME/DME
O4	Basic RNP 1 DME/DME/IRU
S1	RNP APCH
S2	RNP APCH with baro-VNAV
T1	RNP AR APCH with RF (special authorization required)
T2	RNP AR APCH without RF (special authorization required)

Combinations of alphanumeric characters not indicated above are reserved.

ICAO has not yet allocated a two-digit alphanumeric character to describe RNP 2 under the PBN/ indicator. For an RNP 2 capable flight, enter a Z in item 10 and spell out “RNP2” after NAV/ in item 18: NAV/RNP2.

NAV/ Significant data related to navigation equipment other than that specified in PBN/, as required by the appropriate ATS authority. Indicate GNSS augmentation under this indicator, with a space between two or more methods of augmentation, e.g. NAV/GBAS SBAS.

COM/ Indicate communications applications or capabilities not specified in Item 10(a).

DAT/ Indicate data applications or capabilities not specified in 10(a).

SUR/ Include surveillance applications or capabilities not specified in Item 10(b), e.g., SUR/CANMANDATE (see section 3.15.4.2 of the RAC chapter).

DEP/ Name and location of departure aerodrome, if “ZZZZ” is inserted in Item 13, or the ATS unit from which supplementary flight plan data can be obtained, if “AFIL” (airfile) is inserted in Item 13. For aerodromes not listed in the relevant AIP, indicate location as follows:

(a) With four figures describing latitude in degrees and tens and units of minutes followed by “N” (North) or “S” (South), followed by five figures describing longitude in degrees and tens and units of minutes, followed by “E” (East) or “W” (West). Make up the correct number of figures, where necessary, by insertion of zeros, e.g. 4620N07805W (11 characters); OR

(b) Bearing and distance from the nearest significant point, as follows:

(i) The identification of the significant point followed by the bearing from the point in the form of three figures giving degrees magnetic, followed by the distance from the point in the form of three figures expressing nautical miles. In areas of high latitude where it is determined by the appropriate authority that reference to degrees magnetic is impractical, degrees true may be used. Make up the correct number of figures, where necessary, by insertion of zeros, e.g. a point of 180° magnetic at a distance of 40 NM from VOR “DUB” should be expressed as DUB180040; OR

(ii) The first point of the route (name or LAT/LONG) or the marker radio beacon, if the aircraft has not taken off from an aerodrome.

DEST/ Name and location of the destination aerodrome, if “ZZZZ” is inserted in Item 16. For aerodromes not listed in the relevant AIP, indicate location in LAT/LONG or bearing and distance from the nearest significant point, as described under DEP/, above.

DOF/ The date of flight departure in a six-figure format (YYMMDD, where YY equals the year, MM equals the month and DD equals the day).

REG/ The nationality or common mark and registration mark of the aircraft, if different from the aircraft identification in Item 7.

EET/ Significant points or FIR boundary designators and accumulated EETs from takeoff to such points or FIR boundaries, when so prescribed on the basis of regional air navigation agreements, or by the appropriate ATS authority.

Examples:

EET/CAP0745 XYZ0830/

EET/EINN0204

SEL/ SELCAL Code, for aircraft so equipped.

TYP/ Type(s) of aircraft, preceded if necessary without a space by number(s) of aircraft and separated by one space, if “ZZZZ” is inserted in Item 9.

Example:

TYP/2F15 5F5 3B2

DLE/ En-route delay or holding, insert the significant point(s) on the route where a delay is planned to occur, followed by the length of delay using four-figure time in hours and minutes (hhmm).

Example:

DLE/MDG0030

OPR/ ICAO designator or name of the aircraft operating agency, if different from the aircraft identification in Item 7.

ORGN/ The originator’s eight-letter AFTN address or other appropriate contact details, in cases where the originator of the flight plan may not be readily identified, as required by the appropriate ATS authority.

NOTE:

In some areas, flight plan reception centres may insert the “ORGN/” identifier and originator’s AFTN address automatically.

PER/ Aircraft performance data, indicated by a single letter as specified in the *Procedures for Air Navigation Services—Aircraft Operations* (PANS-OPS, ICAO Doc 8168), *Volume I — Flight Procedures*, if so prescribed by the appropriate ATS authority.

ALTN/ Name of destination alternate aerodrome(s), if “ZZZZ” is inserted in Item 16. For aerodromes not listed in the relevant AIP, indicate location in LAT/LONG or bearing and distance from the nearest significant point, as described in DEP/, above.

RALT/ ICAO four-letter indicator(s) for en-route alternate(s), as specified in ICAO Doc 7910—*Location Indicators*,

	or name(s) of en-route alternate aerodrome(s), if no indicator is allocated. For aerodromes not listed in the relevant AIP, indicate location in LAT/LONG or bearing and distance from the nearest significant point, as described in DEP/, above.	J/(JACKETS) CROSS OUT all indicators if life jackets are not carried. CROSS OUT indicator “L” if life jackets are not equipped with lights. CROSS OUT indicator “F” if life jackets are not equipped with fluorescein. CROSS OUT indicator “U” or “V” or both (as in R/, above) to indicate radio capability of jackets, if any.
TALT/	ICAO four-letter indicator(s) for takeoff alternate, as specified in ICAO Doc 7910— <i>Location Indicators</i> , or name of takeoff alternate aerodrome, if no indicator is allocated. For aerodromes not listed in the relevant AIP, indicate location in LAT/LONG or bearing and distance from the nearest significant point, as described in DEP/, above.	D/(DINGHIES) (NUMBER) CROSS OUT indicators “D” and “C” if no dinghies are carried, or INSERT number of dinghies carried; and (CAPACITY)
RIF/	The route details to the revised destination aerodrome, following by the ICAO four-letter location indicator of the aerodrome. The revised route is subject to reclearance in flight.	INSERT total capacity, in persons, of all dinghies carried; and (COVER) CROSS OUT indicator “C” if dinghies are not covered; and (COLOUR) INSERT colour of dinghies, if carried.
Examples:		
	<i>RIF/DTA HEC KLAX</i>	
	<i>RIF/ESP G94 CLA YPPH</i>	
RMK/	Any other plain-language remarks when required by the appropriate ATS authority or deemed necessary, e.g. TCAS- equipped—ICAO only.	A/(AIRCRAFT COLOUR AND MARKINGS) INSERT colour of aircraft and significant markings. Canadian use only: Tick appropriate box for wheels, skis, etc. N/(REMARKS) CROSS OUT indicator “N” if no remarks, or INDICATE any other survival equipment carried and any other remarks regarding survival equipment. INDICATE if aircraft is equipped with a ballistic parachute system. ARRIVAL REPORT Canadian use only: Fill in the required information. AIRCRAFT Canadian use only: Indicate the aircraft owner, person(s) or company to be notified if SAR action is initiated. C/(PILOT) INSERT name of pilot-in-command. Canadian use only: INSERT pilot’s licence number.
3.15.9 Item 19: Supplementary Information		
3.15.9.1 Endurance		
AFTER “E/”		
	INSERT a four-figure group giving the fuel endurance in hours and minutes.	
3.15.9.2 Persons On Board		
AFTER “P/”		
	INSERT the total number of persons (passengers and crew) on board, when required by the appropriate ATS authority. INSERT “TBN” (to be notified) if the total number of persons is not known at the time of filing.	
3.15.9.3 Emergency and Survival Equipment		
R/(RADIO)		
	CROSS OUT indicator “U” if UHF on frequency 243.0 MHz is not available. CROSS OUT indicator “V” if VHF on frequency 121.5 MHz is not available. CROSS OUT indicator “E” if an ELT is not available. Canadian use only: ELT categories should be entered in the “ELT TYPE” box on the flight plan and flight itinerary forms.	
S/(SURVIVAL EQUIPMENT)		
	CROSS OUT all indicators if survival equipment is not carried. CROSS OUT indicator “P” if polar survival equipment is not carried. CROSS OUT indicator “D” if desert survival equipment is not carried. CROSS OUT indicator “M” if maritime survival equipment is not carried. CROSS OUT indicator “J” if jungle survival equipment is not carried.	

Figure 3.1—Composite IFR/VFR/IFR Flight Itinerary

NAV CANADA CANADIAN FLIGHT PLAN / ITINÉRAIRE DE VOL CANADIEN ICAO FLIGHT PLAN PLAN DE VOL OACI

PRIORITY / PRIORITE: FF
ADDRESSEES / DESTINATAIRES: [Empty]
ORIGINATOR / EXPÉDITEUR: [Empty]
FLYING TIME / HEURE DE DÉPART: 0900
SPECIFIC IDENTIFICATION OF ADDRESSEES AND/OR ORIGINATOR / IDENTIFICATION PRÉCISE D'UNES DESTINATAIRES(S) ET/OU DE L'EXPÉDITEUR: [Empty]

3 MESSAGE TYPE / TYPE DE MESSAGE: FPL
7 AIRCRAFT IDENTIFICATION / IDENTIFICATION DE L'AÉRONEF: C F A B C
8 FLIGHT RULES / RÈGLES DE VOL: Y
TYPE OF FLIGHT / TYPE DE VOL: F
9 NUMBER / NOMBRE: 100
TYPE OF AIRCRAFT / TYPE D'AÉRONEF: B E I O
WAKE TURBULENCE CAT. / CAT. DE TURBULENCE DE SILLAGE: 1
10 EQUIPMENT / ÉQUIPEMENT: S D C
13 DEPARTURE AERODROME / AERODROME DE DÉPART: C Y X E
TIME / HEURE: 0900
15 CRUISING SPEED / VITESSE DE CRUIZÈRE: N 0 1 7 0
ALTITUDE / LEVEL / NIVEAU: A 0 5 0 0
ROUTE / ROUTE: V 3 0 6 V L N V F R J Q 3 (5 2 0) J Q 3
V L N / N 0 1 7 0 A 0 6 0 I F R V 3 0 6 Y X E
16 DESTINATION AERODROME TOTAL EET / DURÉE TOTALE ESTIMÉE: C Y P A
AERODROME DE DESTINATION (DAYS/DOURS) HRS: 0 2 0 6 0 0
MIN: 0 6 0 0
2ND ALTN. AERODROME / AERODROME DE DÉGAGEMENT: C Y P A
18 OTHER INFORMATION / RENSEIGNEMENTS DIVERS: [Empty]

19 ENDURANCE / AUTONOMIE: 5
SURVIVAL EQUIPMENT / ÉQUIPEMENT DE SURVIE: POLAR (S), DESERT (P), MARITIME (M), JUNGLE (J), JACKETS / GILETS DE SAUVETAGE (J), LIGHT (L), FLOODS (F), LIFE (V), VHF (E), ELT TYPE (A, P)
AIRCRAFT COLOUR AND MARKINGS / COULEUR ET MARQUÉS DE L'AÉRONEF: RED ON WHITE
REMARKS / REMARQUES: AN ARRIVAL REPORT WILL BE FILED WITH - UN COMPTE RENDU D'ARRIVÉE SERA NOTIFIÉ A: SASKATOON TOWER
PILOT-IN-COMMAND / PILOTE COMMANDANT DE BORD: S. RENNICK
PILOTS LICENCE No./N° DE LICENCE DU PILOTE: 123456

Explanation of Figure 3.1—Composite IFR/VFR/IFR Flight Itinerary

Item 7:

Aircraft identification

Item 8:

“Y” indicates that the flight will be initially operated under the IFR, followed by one or more subsequent changes of flight rules.

“F” indicates that it is a flight itinerary.

Item 9:

Aircraft is a Beechcraft 100.

Item 10:

“S” indicates standard COM/NAV equipment of VHF, RTF, VOR and ILS.

“D” indicates DME equipped.

“C” indicates transponder Mode A (four digits—4096 codes) and Mode C.

Item 13:

Departure aerodrome is Saskatoon at 0900 UTC.

Item 15:

Speed is 170 kt.

Altitude is 5 000 ft.

Route is V306 to the Lumsden VOR.

“VFR” indicates a change in flight rules to VFR at Lumsden.

“JQ3” indicates direct flight from Lumsden to the aerodrome at Carlyle.

“(5200)” indicates a stopover at Carlyle in hours and minutes.

Second “JQ3” indicates there will be a stopover at Carlyle.

“VLN” indicates direct flight from Carlyle to the Lumsden VOR.

“N0170A060IFR” indicates that the altitude is changed to 6 000 ft and the next leg will be IFR (although the speed did not change; if there is a change to either speed or altitude, both have to be indicated).

Route is V306 from Lumsden to the Saskatoon VOR.

Item 16:

Destination aerodrome is Saskatoon.

EET from takeoff to landing at Saskatoon is 2 days and 6 hours (this includes the flight time and the stopover time at Carlyle).

SAR time of 6 hours indicates the pilot’s desire to have SAR action initiated at 6 hours after the total EET of the trip; in other words, 2 days and 12 hours after takeoff from Saskatoon (if there is no entry in this block the SAR activation time would be 24 hours after the EET).

Alternate aerodrome is Prince Albert.

Item 18:

Although no other information is provided in this example, this section is for listing any other information as previously described.

Item 19:

Flying time endurance is 5 hr. There are two people in the aircraft (including crew).

“X” over “U” indicates there is no UHF emergency radio.

Unaltered “V” indicates there is VHF emergency radio.

Unaltered “E” under ELT indicates there is an emergency locator transmitter.

“AP” under ELT TYPE indicates an automatic portable ELT.

Unaltered “P” under POLAR indicates polar equipment is carried.

Unaltered “J” and “L” indicates that life jackets with lights are carried.

“Xs” on “D” and “C” indicate there are no dinghies.

Aircraft colour and markings are self explanatory.

“X” on “N” indicates there are no additional remarks on survival gear.

Example indicates closure with Saskatoon tower.

Contact name and number is self explanatory.

Pilot’s licence number assists SAR specialists in their search.

RAC

Figure 3.2—IFR Flight Plan (ICAO)

NAV CANADA		CANADIAN FLIGHT PLAN / ITINERARY PLAN DE VOL / ITINÉRAIRE DE VOL CANADIEN		ICAO FLIGHT PLAN PLAN DE VOL OACI	
PRIORITY / PRIORITÉ FF		ADDRESSES / DESTINATAIRES			
FLIGHT TIME / HEURE DE DÉPART		ORIGINATOR / EXPÉDITEUR			
SPECIFIC IDENTIFICATION OF ADDRESSES AND/OR ORIGINATOR / IDENTIFICATION PRÉCISE DU(DES) DESTINATAIRE(S) ET/OU DE L'EXPÉDITEUR					
3 MESSAGE TYPE / TYPE DE MESSAGE FPL	7 AIRCRAFT IDENTIFICATION / IDENTIFICATION DE L'AÉRONEF A, C, A, 8, 5, 6, 1	8 FLIGHT RULES / RÈGLES DE VOL I	TYPE OF FLIGHT / TYPE DE VOL S		
9 NUMBER / NUMÉRO 1	TYPE OF AIRCRAFT / TYPE D'AÉRONEF B, 7, 4, 7	WAKE TURBULENCE CAT. / CAT. DE TURBULENCE DE SILLAGE 1	10 EQUIPMENT / ÉQUIPEMENT S, X, S		
13 DEPARTURE AERODROME / AÉRODROME DE DÉPART C, Y, U, L		TIME / HEURE 0, 0, 5, 2			
15 CRUISING SPEED / VITESSE DE CROISIÈRE N, 0, 4, 3, 8					
16 DESTINATION AERODROME / AÉRODROME DE DESTINATION E, G, L, L					
18 OTHER INFORMATION / RENSEIGNEMENTS DIVERS EET/YE 00137 YYR015 SCR D 0 0 0 W 0 234 40W 0312 EEGX 0350 Q0W 0426 10W 006 BEL 0526 RES/CSACA SEL/EHFK					
19 ENDURANCE / AUTONOMIE E / 0, 3, 0, 0		PERSONNEL À BORD P / 3, 4, 5		EMERGENCY RADIO / RADIO DE SECOURS R / U, V, E	
20 AIRCRAFT COLOUR AND MARKINGS / COULEUR ET MARQUES DE L'AÉRONEF A / WHITE					
FILED BY / DÉPOSÉ PAR C / S. RENNICK					

Figure 3.3—VFR Flight Plan

NAV CANADA		CANADIAN FLIGHT PLAN / ITINERARY PLAN DE VOL / ITINÉRAIRE DE VOL CANADIEN		ICAO FLIGHT PLAN PLAN DE VOL OACI	
PRIORITY / PRIORITÉ FF		ADDRESSES / DESTINATAIRES			
FLIGHT TIME / HEURE DE DÉPART		ORIGINATOR / EXPÉDITEUR			
SPECIFIC IDENTIFICATION OF ADDRESSES AND/OR ORIGINATOR / IDENTIFICATION PRÉCISE DU(DES) DESTINATAIRE(S) ET/OU DE L'EXPÉDITEUR					
3 MESSAGE TYPE / TYPE DE MESSAGE FPL	7 AIRCRAFT IDENTIFICATION / IDENTIFICATION DE L'AÉRONEF C, F, A, B, C, 1	8 FLIGHT RULES / RÈGLES DE VOL V	TYPE OF FLIGHT / TYPE DE VOL S, I, C		
9 NUMBER / NUMÉRO 1	TYPE OF AIRCRAFT / TYPE D'AÉRONEF C, 1, 7, 2, 0	WAKE TURBULENCE CAT. / CAT. DE TURBULENCE DE SILLAGE 1	10 EQUIPMENT / ÉQUIPEMENT S, I, C		
13 DEPARTURE AERODROME / AÉRODROME DE DÉPART C, Y, O, W		TIME / HEURE 0, 9, 0, 0			
15 CRUISING SPEED / VITESSE DE CROISIÈRE N, 0, 1, 2, 0					
16 DESTINATION AERODROME / AÉRODROME DE DESTINATION C, Y, G, H					
18 OTHER INFORMATION / RENSEIGNEMENTS DIVERS Y, S, H					
19 ENDURANCE / AUTONOMIE E / 0, 3, 0, 0		PERSONNEL À BORD P / 0, 2		EMERGENCY RADIO / RADIO DE SECOURS R / U, V, E	
20 AIRCRAFT COLOUR AND MARKINGS / COULEUR ET MARQUES DE L'AÉRONEF A / RED ON WHITE					
FILED BY / DÉPOSÉ PAR C / S. RENNICK					

4.0 Airport Operations

4.1 General

Pilots must be particularly alert when operating in the vicinity of an airport. Increased traffic congestion, aircraft in climb and descent attitudes, and pilots preoccupied with cockpit duties are some of the factors that increase the accident potential near airports. The situation is further compounded when the weather only just meets VFR requirements.

Several operators have, for some time, been using their landing lights when flying at lower altitudes and within terminal areas, both during daylight hours and at night. Pilot comment has confirmed that the use of landing lights greatly increases the probability of the aircraft being seen. An important side benefit for improved safety is that birds appear to see aircraft showing lights in time to take avoiding action. In view of this, it is recommended that, when so equipped, all aircraft use landing lights during the takeoff and landing phases and when flying below 2 000 ft AGL within terminal areas and aerodrome traffic patterns.

ATC towers equipped with ATS surveillance have the capability of providing an increased level of service to the aviation community. The class of airspace determines the controller's responsibilities vis-à-vis separation between IFR and VFR aircraft, and between VFR and VFR aircraft. Control staff in certain towers will be able to assist aircraft in establishing visual separation through the provision of vectors, ATS surveillance monitoring and altitude assignments. Use of the surveillance will also result in more efficient control of VFR aircraft.

While aircraft shall not be operated at speeds greater than 200 KIAS below 3 000 ft AGL and within 10 NM of a controlled aerodrome (CAR 602.32), there is no mandatory speed restriction when operating in the vicinity of an uncontrolled aerodrome. As traffic levels at some of these aerodromes may be high from time to time, the risk of a possible mid-air collision is somewhat elevated during these periods. For this reason, it is recommended that pilots reduce their aircraft speed to the maximum extent possible when operating below 3 000 ft AGL and within 10 NM of an uncontrolled aerodrome.

Incidents have occurred when aircraft are being operated VFR within control zones, when the flight visibility is less than three miles due to local smoke, haze, rain, snow, fog or other condition. CAR 602.114 requires a minimum of three miles ground visibility for VFR flight within a control zone. This visibility is, of course, taken by a person on the ground and does not preclude the possibility that the visibility aloft may be less. Good airmanship requires that a pilot encountering less than three miles flight visibility within a control zone will either:

- (a) take action to avoid the area of reduced visibility; or
- (b) remain clear of the area of reduced visibility and request a special VFR clearance from ATC.

Pilots shall maintain a listening watch on the appropriate tower frequency while under control of the tower. Whenever possible, requests for radio checks and taxi instructions should be made on the appropriate ground control frequency. After establishing

RAC

initial contact with the control tower, pilots will be advised of any frequency changes required.

4.1.1 Wake Turbulence

Wake turbulence has its greatest impact on departure and arrival procedures; however, pilots should not assume that it will only be encountered in the vicinity of aerodromes. Caution should be exercised whenever a flight is conducted anywhere behind and at less than 1 000 ft below a large aircraft.

Vectoring

Controllers apply the following wake turbulence ATS surveillance separation minima between a preceding IFR/VFR aircraft and an aircraft vectored directly behind it and at less than 1 000 ft during any phase of flight.

Categories, weight limits, aircraft examples and separation criteria are indicated in the table below.

Table 4.1—Separation per Aircraft Category for Wake Turbulence Purposes

Category	Limits	Examples	Separation (NM)
SUPER HEAVY (S)	This category currently only applies to Airbus A380 aircraft with a maximum takeoff mass of 560 000 kg.	A380-800	Super Heavy behind a Super Heavy - 4 mi.
HEAVY (H)	Aircraft types weighing less than 560 000 kg but more than 136 000 kg	B747/B777/B767 A340A330/MD11	Heavy behind a Super Heavy - 6 mi. Heavy behind a Heavy - 4 mi.
MEDIUM (M)	Aircraft types weighing less than 136 000 kg but more than 7 000 kg	B757/B737/A320 ERJ145/TU154	Medium behind a Super Heavy - 7 mi. Medium behind a Heavy - 5 mi.
LIGHT (L)	Aircraft types weighing 7 000 kg or less	C150/C152 C172/ C182/PA38/PA2	Light behind a Super Heavy - 8 mi.
			Light behind a Heavy - 6 mi.
			Light behind a Medium - 4 mi.

Non-Surveillance Departures

Controllers will apply a two-minute separation interval to any aircraft that takes off into the wake of a known heavy aircraft if:

- (a) the aircraft concerned commences the takeoff from the threshold of the same runway; or
- (b) any following aircraft departs from the threshold of a parallel runway that is located less than 2 500 ft away from the runway used by the preceding heavy aircraft.

NOTE:

ATC does not apply this two-minute spacing interval between a light following a medium aircraft in the above circumstances, but will issue wake turbulence advisories to light aircraft. Controllers will apply a three-minute separation interval to any aircraft that takes off into the wake of a known heavy aircraft, or a light aircraft that takes off into the wake of a known medium aircraft if:

- (a) the following aircraft starts its takeoff roll from an intersection or from a point further along the runway than the preceding aircraft; or
- (b) the controller has reason to believe that the following aircraft will require more runway length for takeoff than the preceding aircraft.

ATC will also apply separation intervals of up to three minutes when the projected flight paths of any following aircraft will cross that of a preceding heavy aircraft.

In spite of these measures, ATC cannot guarantee that wake turbulence will not be encountered.

Pilot Waivers

ATC tower controllers are required to advise pilots whenever a requested take-off clearance is denied solely because of wake turbulence requirements. The intention of this advisory is to make pilots aware of the reason for the clearance denial so that they may consider waiving the wake turbulence requirement. To aid in the pilot's decision, the tower controller will advise the type and position of the wake-creating aircraft. The following phraseologies will be used by the controller in response to a request for take-off clearance when wake turbulence is a consideration:

Tower: *NEGATIVE, HOLD SHORT WAKE TURBULENCE. HEAVY BOEING 747, ROTATING AT 6 000 FT;* or

Tower: *LINE UP AND WAIT, WAKE TURBULENCE, HEAVY DC10 AIRBORNE AT 2 MI.*

Pilots are reminded that there are some circumstances where wake turbulence separation cannot be waived.

There may be departure situations, such as with a steady crosswind component, where the full wake turbulence separation minima is not required. The pilot is in the best position to make an assessment of the need for wake turbulence separation. Although controllers are not permitted to initiate waivers to wake turbulence separation minima, they will issue takeoff clearance to pilots who have waived wake turbulence requirements on their own initiative, with the following exceptions:

- (a) a light or medium aircraft taking off behind a heavy aircraft and takeoff is started from an intersection or a point significantly further along the runway, in the direction of takeoff; or
- (b) a light or medium aircraft departing after a heavy aircraft takes off or makes a low or missed approach in the opposite direction on the same runway; or
- (c) a light or medium aircraft departing after a heavy aircraft makes a low or missed approach in the same direction on the same runway.

A pilot-initiated waiver for a VFR departure indicates to the controller that the pilot accepts responsibility for wake turbulence separation. The controller will still issue a wake turbulence cautionary with the takeoff clearance. Controllers are responsible for ensuring wake turbulence minima are met for IFR departures. More information on wake turbulence can be found in the AIR section of this manual.

4.1.2 Noise Abatement

Pilots and operators must conform to the applicable provisions of CAR 602.105—*Noise Operating Criteria*, and CAR 602.106—*Noise Restricted Runways* (see RAC Annex) and the applicable noise abatement procedures published in the CAP.

Noise operating restrictions may be applied at any aerodrome where there is an identified requirement. When applied at an aerodrome, the procedures and restrictions will be set out in the CFS, and shall include procedures and requirements relating to:

- (a) preferential runways;
- (b) minimum noise routes;
- (c) hours when aircraft operations are prohibited or restricted;
- (d) arrival procedures;
- (e) departure procedures;
- (f) duration of flights;
- (g) the prohibition or restriction of training flights;
- (h) VFR or visual approaches;
- (i) simulated approach procedures; and
- (j) the minimum altitude for the operation of aircraft in the vicinity of the aerodrome.

Transport Canada recognizes the need for analysis and consultation in the implementation of proposed new or amended noise abatement procedures or restrictions at airports and aerodromes. A process has been developed that includes consultation with all concerned parties before new or amended noise abatement procedures or restrictions can be published in

the CAP or the CFS. When the following checklist has been completed for the proposed noise abatement procedures or restrictions, and the resulting analysis has been completed and approved by Transport Canada, the noise abatement procedure or restriction will be published in the appropriate aeronautical publication.

- (a) Description of the problem
- (b) Proposed solution (including possible exceptions)
- (c) Alternatives (such as alternative procedures or land uses in the community)
- (d) Costs (such as revenue impact, direct and indirect costs to the community, airport operator and airport users)
- (e) Noise impacts of the proposed solution
- (f) Effects on aircraft emissions
- (g) Effect on current and future airport capacity
- (h) Implications of not proceeding with the proposal
- (i) Implementation issues (e.g. aircraft technology, availability of replacement aircraft, ground facilities)
- (j) Impact on the aviation system
- (k) Safety implications
- (l) Air traffic management
- (m) Fleet impact

A complete description of the process involved is available on the Internet at: <<https://tc.canada.ca/en/aviation/reference-centre/advisory-circulars/advisory-circular-ac-no-302-002>>

4.1.3 Preferential Runway Assignments

At controlled airports, when selecting preferential runways for noise abatement or for other reasons, air traffic controllers consider the runway condition, the effective crosswind component and the effective tailwind component.

The maximum effective crosswind component considered in determining runway selection is 25 kt for arrivals and departures on DRY runways, and 15 kt on WET runways. The maximum effective tailwind component is 5 kt.

During consultation between NAV CANADA, aviation stakeholders and Transport Canada, it was decided that operations on the preferential runway should be allowed to continue when more than 25 percent of the runway is contaminated, provided:

- (a) The contamination is only TRACE depth.
- (b) The maximum crosswind component does not exceed 15 kt.
- (c) The CRFI reported by the airport operator for all segments of the preferential runway is greater than 0.40.
- (d) There are no braking action reports received from pilots that are less than “good.”

If these conditions are not met, the runway most nearly aligned into the wind must be selected.

Although air traffic controllers may select a preferential runway in accordance with the foregoing criteria, pilots are not obligated to accept the runway for taking off or landing. It remains the pilot’s responsibility to decide if the assigned runway is operationally acceptable.

4.1.4 Runway Protected Area

Runway protected area procedures aim to ensure the runway protected area will be free of objects, which will provide a safe environment during aircraft operations in the event of a runway excursion, arrival undershoot, or departure overrun by an aircraft.

ATC and FSS will hold vehicles and pedestrians and ATC will hold taxiing aircraft at published holding positions or at least 200 ft from the runway edge until an aircraft taking off or landing has passed the holding traffic.

The airport operator may designate an alternate holding position at a distance from the runway edge that ensures no hazard is created for arriving or departing aircraft. The airport operator may also permit pedestrians to operate within the runway protected area when an aircraft is taking off or landing.

Controlled Airports

ATC will not clear an aircraft to take off or land if a holding position is transgressed. If a holding position is transgressed after a takeoff or landing clearance has been issued, ATC will cancel the clearance, unless doing so would create a hazardous situation for the aircraft.

Uncontrolled Airports

FSS will inform pilots of aircraft taking off or landing of runway protected area transgressions and seek the pilots’ intentions.

4.2 Departure Procedures — Controlled Airports

The following departure procedures are based on those applicable for an aerodrome that have all available services, and are listed in the order that they would be used. At smaller, less equipped airports, some services will be combined, e.g. the IFR clearance would be obtained from ground control where there is no separate clearance delivery frequency. Procedures solely applicable to IFR flight are briefly introduced here to establish their sequence. An elaboration thereof may be found in RAC 7.0, Instrument Flight Rules –Departure Procedures.

4.2.1 Automatic Terminal Information Service (ATIS) Broadcasts

If ATIS is available, a pilot should obtain the ATIS information prior to contacting either the ground control or tower. See RAC 1.3 for information on ATIS broadcasts.

4.2.2 Clearance Delivery

At locations where a “clearance delivery” frequency is listed, IFR departures should call on this frequency, prior to requesting taxi authorization, normally no more than 5 minutes prior to

engine start. Where a clearance delivery frequency is not listed, the IFR clearance will normally be given after taxi authorization has been received. At several major aerodromes, departing VFR aircraft are required to contact “clearance delivery” before taxiing. These frequencies, where applicable, are found in the COMM Section of the CFS, for the appropriate aerodrome.

4.2.3 Radio Checks

If required, radio checks should, wherever possible, be requested on frequencies other than ATC frequencies. Normally, the establishment of two-way contact with an agency is sufficient to confirm that the radios are functioning properly.

4.2.4 Requests for Push-back or Power-back

Since controllers may not be in a position to see all obstructions an aircraft may encounter during push-back or power-back, clearance for this manoeuvre will not be issued by the tower. Pilots are cautioned that it is their responsibility to ensure that push-back or power-back can be accomplished safely prior to initiating aircraft movement.

4.2.5 Taxi Information

Taxi authorization should be requested on the ground control frequency. At locations where a “Clearance Delivery” frequency is listed, pilots should obtain their IFR clearance or a VFR code where applicable on this frequency prior to contacting ground control. Where no “Clearance Delivery” frequency is listed, the IFR clearance will normally be relayed by ground control before or after taxi authorization has been issued. If no flight plan has been filed, the pilot should inform the tower “Clearance Delivery”, where available, or ground control of the nature of the flight on initial contact, such as “local VFR” or “proceeding VFR to (destination)”.

Pilot: *WINNIPEG GROUND, AZTEC GOLF JULIETT VICTOR HOTEL AT HANGAR NUMBER THREE, REQUEST TAXI-IFR EDMONTON EIGHT THOUSAND.*

Ground control: *AZTEC GOLF JULIETT VICTOR HOTEL, WINNIPEG GROUND, RUNWAY (number), WIND (in magnetic degrees and knots), ALTIMETER (four-digit group giving the altimeter in inches of mercury), TAXI VIA (runway or other specific point, route), (other information, such as traffic, airport conditions), (CRFI, RSC, or RVR when applicable), CLEARANCE ON REQUEST.*

Pilot: *GOLF JULIETT VICTOR HOTEL.*

Under no circumstances may a taxiing aircraft, whether proceeding to or from the active runway, taxi onto an active runway unless specifically authorized to do so.

Upon receipt of a normal taxi authorization, a pilot is expected to proceed to the taxi-holding position for the runway assigned for takeoff. If a pilot is required to cross any runway while taxiing

towards the departure runway, the ground or airport controller will issue a specific instruction to cross or hold short. If a specific authorization to cross was not received, pilots should hold short and request authorization to cross the runway. Pilots may be instructed to monitor the tower frequency while taxiing or until a specific point, or they may be advised to “contact tower holding short.” The term “holding short,” when used during the communications transfer, is considered as a location and does not require a readback.

In an effort to increase aviation safety by protecting active runways and reducing runway incursions, ATS personnel will request a readback for all HOLD and HOLD SHORT instructions or requests that have not been read back. Pilots are requested to acknowledge and read back such instructions or requests to confirm their intentions with ATS personnel.

Examples of HOLD and HOLD SHORT instructions or requests that should be read back:

HOLD SHORT (runway or taxiway)

HOLD (hold instructions)

REQUEST YOU HOLD SHORT (runway or taxiway)

REQUEST YOU HOLD (hold instructions)

Hold instructions or requests may pertain to a position on a maneuvering area, a direction and point related to a runway or taxiway, or a specific position on a runway or taxiway.

Reminder: In order to reduce frequency congestion, readback of ATC taxi instructions, other than those listed above, is not required in accordance with CAR 602.31(1)(a); such instructions are simply acknowledged. With the increased simultaneous use of more than one runway, however, instructions to enter, cross, backtrack or line up on any runway should also, as a good operating practice, be acknowledged by a readback.

Example:

An aircraft is authorized to backtrack a runway to the holding bay and to report clear when in the holding bay.

Pilot: *CHARLIE FOXTROT ALFA BACKTRACKING RUNWAY TWO FIVE AND WILL REPORT IN THE HOLDING BAY.*

NOTE:

To avoid causing clutter on controllers’ situation displays, pilots should adjust their transponders to “STANDBY” while taxiing and should not switch them to “ON” (or “NORMAL”) until immediately before takeoff.

The tower may instruct aircraft to “line up and wait.” Controllers will issue the name of the runway intersection or taxiway with the authorization if the line-up position is not at the threshold of the departing runway. When more than one entry point for the same runway is in use, ATC will also specify the runway entry point with the instruction to line up at the threshold.

4.2.5.1 Oblique Angle Intersection Use

To mitigate the risk of runway incursions, tower controllers will not permit aircraft to use oblique angle intersections (including

taxiways or intersecting runways) to access an active runway if the departure threshold and final approach are not visible to the flight crew, except under the following circumstances:

- (a) There are no other routes to access the runway without having to taxi or backtrack onto an active runway; or
- (b) There is a non-routine situation that requires the use of oblique angle intersections because no practical alternative exists. This may include a MEDEVAC flight, a closed taxiway, a disabled aircraft, or disabled vehicles.

4.2.5.2 Best Practices for Pilots

A collaborative approach by the aviation industry will help mitigate the risk of collisions from runway incursions.

At uncontrolled aerodromes, pilots are encouraged to avoid using oblique angle intersections that limit their ability to see the active runway threshold and final approach. At controlled aerodromes, pilots are encouraged to avoid requesting to use oblique angle intersections, except when such use can be permitted by tower controllers.

4.2.6 Taxi Holding Positions

Authorization must be obtained before leaving a taxi holding position, or where a holding position marking is not visible or has not been established, before proceeding closer than 200 feet from the edge of the runway in use. At airports where it is not possible to comply with this provision, taxiing aircraft are to remain at a sufficient distance from the runway in use to ensure that a hazard is not created to arriving or departing aircraft.

4.2.7 Taxiway Holding Positions During Instrument Flight Rules (IFR) Operations

It is imperative that aircraft do not proceed beyond taxiway holding signs at controlled airports until cleared by ATC. Aircraft proceeding beyond the taxiway holding position signs may enter electronically sensitive areas and cause dangerous interference to the glide path or localizer signals. In Canada, holding position signs and holding position markings normally indicate the boundaries of electronically sensitive areas, and provide safe obstruction clearance distances from landing runways.

When a controlled airport is operating under CAT II/III weather conditions, or its CAT II/III operations plan is in effect, pilots are to observe CAT II or III mandatory holding position signs. When a controlled airport is not operating under CAT II/III weather conditions, or its LVOP is not in effect, pilots need not abide by the CAT II or III taxiway holding positions and are expected to taxi to the normal taxiway holding position markings, unless advised otherwise by ATC.

At uncontrolled aerodromes, pilots awaiting takeoff should not proceed beyond the holding position signs or holding position markings until there is no risk of collision with landing, taxiing or departing aircraft.

4.2.7.1 Glide Path Signal Protection Procedures

The ILS signal will only be protected under the conditions described below.

A controller will protect the glide path signal when:

- (a) The ceiling is less than 1 000 ft or visibility is less than three miles, or both; and
- (b) The arriving aircraft is inside the FAF on an ILS approach.

NOTE:

At uncontrolled aerodromes, aircraft manoeuvring on the ground may enter ILS critical areas during taxi, takeoff or landing.

4.2.8 Take-off Clearance

When ready for takeoff, the pilot shall request a take-off clearance and should include the runway number. Upon receipt of the take-off clearance, the pilot shall acknowledge it and take off without delay, or inform ATC if unable to do so.

Example:

Pilot: *TOWER, JULIETT GOLF TANGO READY FOR DEPARTURE, RUNWAY THREE SIX.*

Tower: *JULIETT GOLF TANGO, (any special information such as hazards, obstructions, turn after takeoff, wind information if required, etc.), CLEARED FOR TAKEOFF RUNWAY THREE SIX (or JULIETT GOLF TANGO, FROM GOLF, CLEARED FOR TAKEOFF RUNWAY THREE SIX).*

Pilot: *JULIETT GOLF TANGO.*

Pilots may request to use the full length of the runway for takeoff at any time. If the runway is to be entered at an intersection and back tracking is required, pilots should indicate their intentions and obtain a clearance for the manoeuvre before entering the runway.

Pilots may request, or the controller may suggest, takeoff using only part of a runway. The pilot's request will be approved, provided noise abatement procedures, traffic, and other conditions permit. If suggested by the controller, the available length of the runway will be stated. It is the pilot's responsibility to ensure that the portion of the runway to be used will be adequate for the take-off run.

To expedite movement of airport traffic and achieve spacing between arriving and departing aircraft, take-off clearance may include the word "immediate." In such cases, "immediate" is used for the purpose of air traffic separation. On acceptance of the clearance, the aircraft shall taxi onto the runway and take off in one continuous movement. If, in the pilot's opinion, compliance would adversely affect their operations, the pilot should refuse the clearance. Pilots planning a static takeoff (i.e. a full stop after "lined up" on the runway), or a delay in takeoff, should indicate this when requesting take-off clearance. ATC will specify the name of the taxiway or intersection with the clearance for takeoff from a taxiway or runway intersection. When more than one entry point for the same runway is in use, ATC will also specify the threshold as the point from which the

take-off run will commence for those aircraft departing from the threshold. A controller may not issue a clearance that would result in a deviation from established noise abatement procedures or wake turbulence separation minima.

4.2.8.1 Air Traffic Control (ATC) Phraseology When a Runway Is Temporarily Shortened Due to Construction

Whenever the length of a runway has been temporarily shortened due to construction, tower controllers will use the word “shortened” immediately following the runway number for all line-up and take-off clearances.

NOTE:

These changes do not transfer pilot responsibility to the controller, but they do ensure that changes in runway length due to construction are communicated as an additional layer of safety.

Example:

Tower Line up Clearance: *GOLF JULIET ECHO TANGO LINE UP RUNWAY ONE-SIX SHORTENED*

4.2.8.2 Clearance for Aborting a Takeoff

Aborting a takeoff is an emergency procedure used by a pilot when continuing the takeoff would present a grave hazard to the aircraft. A controller-initiated aborted takeoff is an extreme measure used only where no clear alternative exists.

Example:

Tower: *ALPHA BRAVO CHARLIE, ABORT ABORT. ALPHA BRAVO CHARLIE, ABORT ABORT (reason)*

4.2.9 Release from Tower Frequency

Unless otherwise advised by ATC, pilots do not require permission to change from tower frequency once clear of the control zone and should not request release from this frequency or report clear of the zone when there is considerable frequency congestion. When practicable, it is recommended that a pilot of a departing aircraft monitor tower frequency until 10 NM from the control zone.

VFR flights will not normally be released from tower frequency while operating within the control zone. Once outside control zones, or when departing from an uncontrolled aerodrome where an MF has been assigned, beyond the range within which MF procedures apply, pilots should monitor frequency 126.7 MHz.

4.2.10 Departure Procedures - No Radio (NORDO) Aircraft

Before proceeding to any portion of the manoeuvring area of a controlled airport, it is the pilot’s responsibility to inform the control tower of his/her intentions and make appropriate arrangements for visual signals.

NOTE:

Before operating within a control zone with Class C airspace, a clearance shall be obtained from the control tower.

A pilot should remain continuously alert for visual signals from the control tower.

An aircraft should remain at least 200 ft from the edge of any runway where holding position markings or signs are not visible or have not been established unless a clearance for takeoff or to cross the runway has been received.

When stopped by a red light, a pilot must wait for a further clearance before proceeding.

When ready for takeoff by day, the pilot may attract the attention of the airport controller by turning the aircraft toward the tower.

Acknowledgement of Visual Signals – pilot shall, where practical, acknowledge all clearances and instructions received by visual signals by day, by full movement of rudder or ailerons, whichever can be seen most easily (such movement should be repeated at least three times in succession), or by taxiing the aircraft to the authorized position.

4.2.11 Visual Signals

Visual signals used by the tower and their meanings are as follows:

Table 4.2—Visuals Signals to Communicate with Aircraft on the Manoeuvring Area, Ground Vehicles and Personnel Not Equipped with a Radio or Unable to Establish or Maintain Radio Contact

	AIRCRAFT ON THE GROUND	VEHICLE OR PERSONNEL
SERIES OF GREEN FLASHES	Cleared to taxi	Cleared to cross; proceed; go
STEADY GREEN LIGHT	Cleared for takeoff	Not used to communicate with vehicles or personnel
SERIES OF RED FLASHES	Taxi clear of landing area or runway in use	Vacate the runway immediately
STEADY RED LIGHT	Stop	Stop; hold your position
FLASHING WHITE LIGHT	Return to starting point on the aerodrome	Return to starting point on the aerodrome
BLINKING RUNWAY LIGHTS	Not used to communicate with aircraft	Vacate the active runway

4.2.12 Departure Procedures – Receiver Only (RONLY) Aircraft

The procedures which apply to aircraft without radio also apply to aircraft equipped with receiver only, except that an airport controller may request the pilot to acknowledge a transmission in a specific manner. After the initial acknowledgement, no further acknowledgement, other than compliance with clearances and instructions, is necessary, unless otherwise requested by the controller.

4.3 Traffic Circuits — Controlled Aerodromes

The following procedures apply to all aerodromes at which a control tower is in operation.

The traffic circuit consists of the crosswind leg, downwind leg, base leg and final approach leg.

Figure 4.1—Standard Left-Hand Traffic Circuit

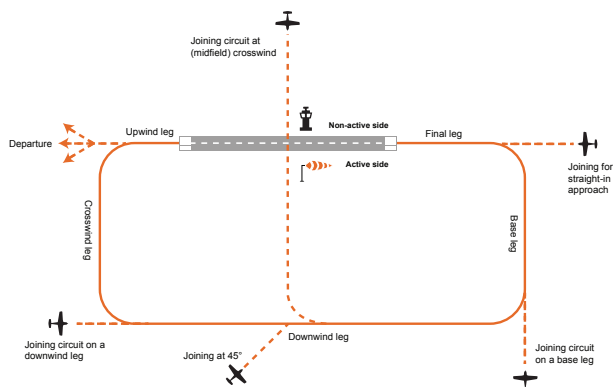

NOTES:

1. Circuit normally flown by aeroplanes at 1 000 ft AAE.
2. Pilots of large and turbine-powered aeroplanes may fly the circuit at 500 ft above the established circuit altitude, if authorized by the air traffic control unit. These aircraft usually operate at a higher speed than piston and electric engine light aeroplanes, have greater turning distances and fly larger circuits.
3. Pilots of rotorcraft will either fly the circuit normally flown by aeroplanes or fly a circuit similar to that flown by aeroplanes but at a lower altitude and closer to the runway, as authorized by the air traffic control unit. Pilots of both helicopters and gyroplanes can be expected to practice power-off landings (autorotation), which involve a very steep approach angle and high descent rate (1 500 to 2 000 ft per minute). This circuit may be on the opposite side of the runway from fixed-wing traffic when airspeed requires it or for practice autorotation landings, if authorized by the air traffic control unit.
4. Helicopters may depart or arrive directly from the helipad on the airfield, the apron or a taxiway, avoiding the fixed wing circuit altogether, if authorized by the air traffic control unit.

5. Pilots of slower, lower-performing aircraft, such as some ultra-light aeroplanes, fly the circuit at lower altitudes and inside the standard traffic circuit established for the aerodrome, if authorized by the air traffic control unit. The pilot may vary the size of the traffic pattern depending on their aircraft’s performance characteristics. An aerodrome with a dedicated landing area for ultra-light aeroplanes may have a lower traffic pattern parallel to the standard circuit, with turns in the opposite direction. Some of these ultra-light aeroplanes fly significantly slower than many other aircraft, exhibit steep takeoff and approach angles and make turns near the end of the runway to clear the area expediently.
6. Glider circuits typically have entry points that differ from the standard circuit. Gliders typically operate on the downwind leg between 500 and 1 000 ft AAE and fly a diagonal leg between the downwind and base leg. This circuit may be on the opposite side of the runway from powered aircraft traffic, if authorized by the air traffic control unit. Pilots of powered aircraft are reminded that gliders are usually unable to maintain altitude in a circuit and that, in accordance with the *Canadian Aviation Regulations* (CAR) 602.19, power-driven, heavier-than-air aircraft must give way to gliders. Gliders typically fly a steeper final approach glidepath (approximately 8 degrees).
7. Balloons have the right of way over all other aircraft categories and do not follow a standard circuit.
8. Where a right-hand circuit is required in accordance with CAR 602.96(3)(c), the opposite of this diagram is applicable.

Entry to the circuit shall be made in such a manner so as to avoid cutting off other aircraft, conforming as closely as possible to the altitude, speed and size of the circuit being flown by other aircraft of similar performance.

To increase safety by reducing the possibility of conflicting with departing traffic and if authorized by the air traffic control unit, aircraft approaching the active runway from the non-active side are to join the downwind leg abeam a point approximately midway between each end of the runway, taking into account aircraft performance, wind and/or runway length.

Pilots are responsible to see and avoid other aircraft and to help others see and avoid their aircraft, even when operating under an air traffic control clearance. Keep landing lights and strobes on. It is a best practice to operate the transponder at all times, even outside of transponder airspace, as some aircraft have collision avoidance systems that alert them of conflicting air traffic.

Pilots of no radio (NORDO) and receiver only (RONLY) aircraft who have made specific arrangements to operate within the control zone (RAC 4.4.5 and RAC 4.4.6) should approach the circuit from the non-active side, join crosswind at circuit height and, taking due account of other traffic, join the circuit on the downwind leg. Pilots are cautioned to remain clear of the approach and/or departure path of the active runway when joining the circuit (see Figure 4.1). Flights which are not in communication with the air traffic control tower shall, at all times, be on the alert for visual signals. Pilots are reminded that below 3 000 ft AGL and within 10 NM of a controlled aerodrome, aircraft shall

not be operated at speeds greater than 200 KIAS. However, where the minimum safe speed of the aircraft is greater than 200 KIAS, the aircraft may be operated at the minimum safe speed (CAR 602.32).

4.4 Arrival Procedures — Controlled Airports

If ATIS is available, all arrivals shall monitor this frequency to obtain the basic aerodrome information prior to contacting the tower. (See RAC 1.3 for ATIS information and refer to RAC 5.8 for arrival procedures in Class C airspace, other than a control zone.)

4.4.1 Initial Contact

Pilots must establish and maintain radio communications with the appropriate control tower prior to operating within any control zone served by an operational control tower. Also, if the control zone is Class B or C airspace, the appropriate clearance must be received from the controlling agency prior to entry.

When practical, it is recommended that the pilot make initial contact at least 5 minutes prior to requiring clearance or entering the zone.

4.4.2 Initial Clearance

On initial contact with the tower, unless the pilot advises receipt of ATIS, the airport controller will inform the pilot of runway in use, wind direction and speed, altimeter setting and any other pertinent information. Following this, the pilot will receive clearance to proceed, including any necessary restrictions. The shortest routing to the runway may be expected if traffic permits. Pilots of VFR aircraft should check the CFS (or a VTA chart if applicable) for special procedures at the time of flight planning.

When a pilot is given a clearance “to the circuit” by ATC, it is expected that the aircraft will join the circuit on the downwind leg at circuit height. Depending on the direction of approach to the airport and the runway in use, it may be necessary to proceed crosswind prior to joining the circuit on the downwind leg.

The ATC phraseology “cleared to the circuit” authorizes a pilot to make a right turn in order to join crosswind, or partial right turn to join a left-hand circuit provided that the right turn or partial right turn can be carried out safely.

A straight-in approach is an approach where an aircraft joins the traffic circuit on the final leg without having executed any other portion of the circuit.

When an aircraft is cleared for a right-hand approach while a left-hand circuit is in effect, it shall be flown so as to join the circuit on the right-hand downwind leg, or join directly into the right-hand base leg, as cleared by the airport controller.

Pilot: *KELOWNA TOWER, CESSNA FOXTROT ALFA BRAVO CHARLIE, ONE FIVE MILES NORTH, SIX THOUSAND FIVE HUNDRED FEET VFR, REQUEST LANDING INSTRUCTIONS.*

Tower: *CESSNA FOXTROT ALFA BRAVO CHARLIE, KELOWNA TOWER, RUNWAY (number), WIND*

(direction in degrees magnetic, speed in knots), ALTIMETER (4-digit group in inches), (other pertinent instructions or information if deemed necessary), CLEARED TO THE CIRCUIT or CLEARED TO LEFT BASE LEG or CLEARED STRAIGHT-IN APPROACH.

Pilot: *ALFA BRAVO CHARLIE.*

When a pilot has received current landing information from the tower or the ATIS broadcast, initial clearance may be requested as follows:

Pilot: *VICTORIA TOWER, CESSNA FOXTROT ALFA BRAVO CHARLIE (aircraft position), ALTITUDE, CHECK LANDING INFORMATION (or) WITH INFORMATION (ATIS code). REQUEST CLEARANCE TO THE CIRCUIT (or other type of approach).*

Once established in the circuit as cleared, the pilot is to advise the tower accordingly.

Pilot: *TOWER, ALFA BRAVO CHARLIE DOWNWIND.*

Tower: *ALFA BRAVO CHARLIE NUMBER (approach sequence number). If not Number 1, the tower will give the type, position and colour if significant, of aircraft to follow and other instructions or information.*

Pilot: *ALFA BRAVO CHARLIE.*

Common ATC Phraseologies:

FOLLOW (aircraft type) NOW ON BASE LEG.

EXTEND DOWNWIND.

WIDEN APPROACH.

VFR Holding Procedures

When it is required by traffic, VFR flights may be asked to ORBIT visually over a geographic location, VFR checkpoint (when these are published in the CFS or VTA charts) until they can be cleared to the airport. If the request is not acceptable, pilots should inform ATC and state their intentions.

Pilot: *TORONTO TOWER, CESSNA FOXTROT ALFA BRAVO CHARLIE, OVER PORT CREDIT AT THREE THOUSAND FIVE HUNDRED FEET WITH INFORMATION ROMEO.*

Tower: *CESSNA FOXTROT ALFA BRAVO CHARLIE, TORONTO TOWER, ORBIT THE FOUR STACKS, ANTICIPATE A FIVE MINUTE DELAY, TRAFFIC IS A CESSNA ONE SEVEN TWO OVER THE FOUR STACKS, LAST REPORTED AT TWO THOUSAND FEET.*

The pilot is expected to proceed to the FOUR STACKS, orbit within visual contact of the checkpoint and be prepared to proceed to the airport immediately upon receipt of a further clearance. Left turns are recommended as terrain and collision avoidance are the pilot's responsibilities.

Tower: *ALFA BRAVO CHARLIE, REPORT LEFT BASE FOR RUNWAY TWO FOUR LEFT. CLEARED TO THE CIRCUIT.*

Pilot: *ALFA BRAVO CHARLIE DEPARTING THE FOUR STACKS AT THIS TIME, WILL REPORT LEFT BASE TO RUNWAY TWO FOUR LEFT; or*

Pilot: *ALFA BRAVO CHARLIE*

4.4.3 Landing Clearance

At controlled airports, a pilot must obtain landing clearance prior to landing. Normally, the airport controller will initiate landing clearance without having first received the request from the aircraft; however, should this not occur, the onus remains upon the pilot to request such clearance in sufficient time to accommodate the operating characteristics of the aircraft being flown. NORDO and RONLY aircraft should be considered as intending to land when they join and conform to the traffic circuit. Landing clearance will normally be given when an aircraft is on final approach. If landing clearance is not received, the pilot should, except in case of emergency, pull up and make another circuit.

Pilot: *TOWER, ALFA BRAVO CHARLIE LANDING CLEARANCE RUNWAY TWO SIX.*

Tower: *ALFA BRAVO CHARLIE, CLEARED TO LAND RUNWAY TWO SIX.*

Pilot: *ALFA BRAVO CHARLIE.*

Controllers may, on occasion, authorize ground traffic to cross the landing runway after a landing clearance has been issued. Any such authorization by ATC is given with the assurance that the runway will be clear of conflicting traffic at the time the arriving aircraft crosses the landing threshold. When it appears that the runway may not be clear for landing, the pilot will be advised to "CONTINUE APPROACH, POSSIBLE PULL-UP." When a "pull-up" is necessary (before or after the landing clearance has been issued), the pilot shall abandon the approach and make another circuit.

Tower: *ALFA BRAVO CHARLIE, TRAFFIC STILL ON RUNWAY, PULL UP AND GO AROUND.*

Common ATC Phraseologies:

CAUTION, POSSIBLE TURBULENCE FROM LANDING (aircraft type and position).

MAKE LEFT/RIGHT THREE SIX ZERO.

MAKE FULL-STOP LANDING.

CONTACT TOWER/GROUND ON (frequency) WHEN OFF RUNWAY/ NOW.

The "cleared for the option" procedure has been introduced to give a pilot the option to make touch-and-gos, low approach, missed approach, stop-and-go, or a full stop landing. This procedure will normally be used during light traffic conditions.

Pilot: *TOWER, ALFA BRAVO CHARLIE, DOWNWIND RUNWAY TWO SEVEN, REQUEST THE OPTION.*

Tower: *ALFA BRAVO CHARLIE, CLEARED FOR THE OPTION RUNWAY TWO SEVEN.*

A clearance for multiple touch-and-gos permits the pilot to perform more than one touch-and-go during a single pass along the runway without stopping. The procedure is intended for student pilots training with an instructor and will only be authorized during light traffic conditions.

Pilot: *TOWER, ALFA BRAVO CHARLIE, DOWNWIND RUNWAY TWO SEVEN, REQUEST MULTIPLE TOUCH-AND-GOS.*

Tower: *ALFA BRAVO CHARLIE, CLEARED MULTIPLE TOUCH-AND-GOS, RUNWAY TWO SEVEN.*

4.4.3.1 Air Traffic Control (ATC) Phraseology When a Runway Is Temporarily Shortened Due to Construction

Whenever the length of a runway has been temporarily shortened due to construction, tower controllers will use the word "shortened" immediately after the runway number on initial contact with arrivals and for all landing clearances.

NOTES:

1. These changes do not transfer pilot responsibility to the controller, but they do ensure that changes in runway length due to construction are communicated as an additional layer of safety.
2. For repetitive operations (ex. circuits), ATC will use the term "shortened" only for the first arrival/departure clearance.

Example:

Tower landing clearance: *GOLF JULIET ECHO TANGO CLEARED TO LAND RUNWAY ONE-SIX SHORTENED*

4.4.4 Taxiing

A pilot must obtain an ATC authorization to taxi on the manoeuvring area at a controlled airport. Unless otherwise instructed by the airport controller, aircraft are expected to continue in the landing direction to the nearest suitable taxiway, exit the runway without delay and obtain further authorization to taxi. No aircraft shall exit a runway onto another runway unless instructed or authorized to do so by ATC. When required, ATC will provide the pilot with instructions for leaving the runway. These instructions will normally be given to the pilot prior to landing or during the landing roll. When an aircraft is instructed to exit onto another runway, the pilot must:

- (a) obtain further authorization to taxi; and
- (b) remain on tower frequency until instructed to change to ground control frequency by ATC.

After landing on a dead-end runway, the pilot will normally be given instructions to backtrack. In all cases, after leaving the runway, unless otherwise instructed by ATC, pilots should continue to taxi forward across the taxi holding position lines or to a point at least 200 ft from the edge of the runway where a taxi holding position line is not available. The aircraft is not considered clear of the runway until all parts of the aircraft are past the taxi holding position line or the 200-ft point.

When clearing landing runways onto taxiways or other runways, pilots should exercise good airmanship by continuing to taxi clear of the hold position while contacting ground control to obtain further taxi instructions. This is to prevent aircraft from blocking a runway exit to following aircraft.

If unable to establish contact with ground control, pilots should stop and not cross any runway without receiving explicit ATC authorization. They should attempt to re-establish communication by reverting to the previous working frequency. If still unable to establish radio contact, pilots should remain alert for visual signals.

Tower: *ALFA BRAVO CHARLIE (instructions for leaving runway), CONTACT GROUND (specific frequency).*

Towers will normally provide the aircraft down time only when requested by the pilot.

Normally, aircraft will not be changed to ground control until off the active runway or runways.

Tower: *ALFA BRAVO CHARLIE, TAXI TO (apron or parking area)(any special instructions such as routing, traffic, cautionary or warning regarding construction or repair on the manoeuvring areas).*

4.4.5 Arrival Procedures – No Radio (NORDO) Aircraft

Before operating into a controlled aerodrome, pilots shall contact the control tower, inform the tower of their intentions and make arrangements for clearance through visual signals.

NOTE:

Before operating within a control zone with Class C airspace, a clearance shall be obtained from the control tower.

Pilots should remain continuously alert for visual signals from the control tower.

Traffic Circuit – The pilot should approach the traffic circuit from the upwind side of the runway, join crosswind at circuit height abeam a point approximately midway between each end of the runway and join the circuit on the downwind leg. While within the circuit the pilot should conform to the speed and size of the circuit, maintaining a separation from aircraft ahead so that a landing can be made without overtaking it. If it is necessary for a flight to cross the airport prior to joining crosswind, this should be done at least 500 feet above circuit height, and descent to circuit height should be made in the upwind area of the active runway.

Final Approach – Before turning on final approach, a pilot shall check for any aircraft on a straight-in approach.

Landing Clearance – Landing clearance will be given on final approach. If landing clearance is not received, the pilot shall, except in case of emergency, pull up and make another circuit. (Landing clearance may be withheld by the tower when there are preceding aircraft which have not landed or if the runway is occupied.)

Taxiing – No taxi clearance is required after landing, except to cross any runway or to taxi back to a turn-off point. When an aircraft's landing run carries it past the last available turn-off point, it should proceed to the end of the runway and taxi to one side, waiting there until instruction is received to taxi back to the nearest turn-off point.

4.4.6 Arrival Procedures – Receiver Only (RONLY) Aircraft

The procedures which apply to aircraft without radio also apply to aircraft equipped with receiver only, except that an airport controller may request the pilot to acknowledge a transmission in a specified manner. After initial acknowledgement, no further acknowledgement other than compliance with clearances and instructions is necessary, unless otherwise requested by the controller.

4.4.7 Visual Signals

Visual signals used by the tower and their meanings are as follows:

Table 4.3—Visuals Signals to Communicate with Aircraft in Flight Not Equipped with a Radio or Unable to Establish Radio Contact

1	STEADY GREEN LIGHT	Cleared to land.
2	STEADY RED LIGHT	Give way to other aircraft and continue circling.
3	SERIES OF GREEN FLASHES	Return for landing. (This shall be followed at the proper time by a steady green light.)
4	SERIES OF RED FLASHES	Aerodrome unsafe; do not land.
5	THE FIRING OF A RED PYROTECHNICAL LIGHT (Military control towers only)	Whether by day or by night and notwithstanding previous instructions, means do not land for the time being.

Acknowledgement of Visual Signals – A pilot shall, where practicable, acknowledge all clearances and instructions received. Signals may be acknowledged as follows:

- (a) distinct rocking of aircraft in flight;
- (b) at night, by a single flash of a landing light.

4.4.8 Communications Failure - Visual Flight Rules (VFR)

CAR 602.138 specifies that where there is a two-way radio communication failure between the controlling air traffic control unit and a VFR aircraft while operating in Class B, Class C or Class D airspace, the pilot-in-command shall:

- (a) leave the airspace
 - (i) where the airspace is a control zone, by landing at the aerodrome for which the control zone is established, and
 - (ii) in any other case, by the shortest route;
- (b) where the aircraft is equipped with a transponder, set the transponder to Code 7600; and
- (c) inform an air traffic control unit as soon as possible of the actions taken pursuant to (i).

Should the communications failure occur while operating outside of Class B, C, or D airspace precluding the pilot from obtaining the appropriate clearance to enter or establishing radio contact, and if no nearby suitable aerodrome is available, the pilot may enter the Class B, C or D airspace, continue under VFR, and shall carry out the remaining procedures listed in (a).

Should the communications failure occur and there is a suitable aerodrome nearby at which the pilot wishes to land, it is recommended that the pilot comply with the established NORDO arrival procedure outlined in RAC 4.4.5.

Pilots operating VFR in either Class E or G airspace may follow the procedures in (a) even though there is no intention to enter Class B, C, or D airspace.

4.4.9 Operations on Intersecting Runways

ATC procedures allow for sequential and/or simultaneous operations on intersecting runways. Their intent is to increase airport traffic capacity, thus reducing delays and saving fuel. These operations differ only in the controllers' application of ATC procedures; ATC advisories will specify the type of operation(s) in progress.

Sequential Operations: Sequential operations do not permit controllers to allow either an arriving aircraft to cross the arrival threshold or a departing aircraft to commence its takeoff roll until certain conditions are met.

For an arriving aircraft (Figure 4.2) the conditions are as follows:

- (a) the preceding departing aircraft has:
 - (i) passed the intersection, or
 - (ii) is airborne and has turned to avoid any conflict;
- (b) the preceding arriving aircraft has:
 - (i) passed the intersection, or
 - (ii) completed its landing roll and will hold short of the intersection (i.e. stopped or at taxi speed), or
 - (iii) completed its landing roll and turned off the runway.

Figure 4.2—Arriving Aircraft

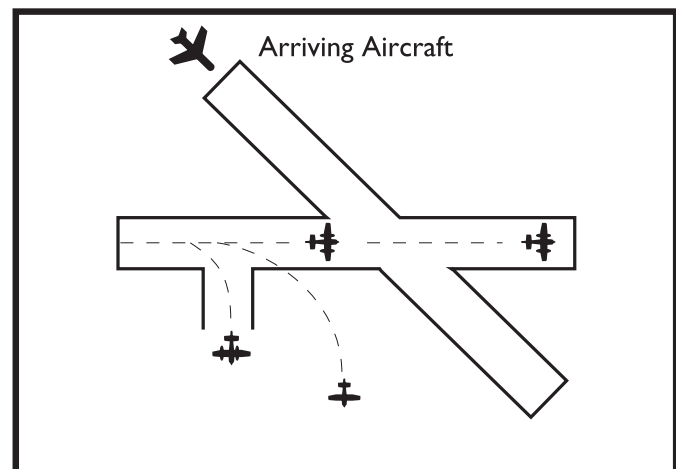

For a departing aircraft (Figure 4.3) the sequential conditions are listed below:

- (a) the preceding departing aircraft
 - (i) has passed the intersection; or
 - (ii) is airborne and has turned to avoid any conflict.
- (b) the preceding arriving aircraft has
 - (i) passed the intersection;
 - (ii) completed its landing roll and will hold short of the intersection (i.e. is stopped or at taxi speed); or
 - (iii) completed its landing roll and turned off the runway.

Figure 4.3—Departing Aircraft

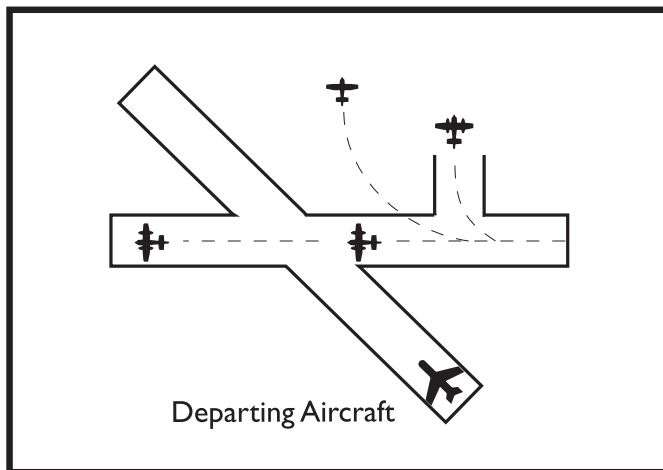

Simultaneous Operations: Simultaneous operations differ from sequential operations in the application of ATC procedures. The procedures for simultaneous use of intersecting runways are applied only between two arrivals or an arrival and a departure. Air traffic controllers will permit an arriving aircraft to cross the runway threshold or a departing aircraft to begin its takeoff roll provided one of the aircraft has accepted a clearance to land and hold short of the intersecting runways (Figure 4.6). These operations are known as land and hold short operations (LAHSO).

General

LAHSO is an air traffic control procedure that requires pilot participation. At an airport with a control tower, ATC may clear a pilot to land and hold short of an intersecting runway. A pilot may only accept a LAHSO clearance if they determine that the aircraft can safely land and stop within the available landing distance.

The PIC has complete authority to accept or decline a LAHSO clearance. The PIC must decline a LAHSO clearance if they believe it would compromise safety.

The runway must be dry (no wet conditions or contaminants are visible from the tower or reported by a competent person) for LAHSO to be carried out.

LAHSO will not be authorized on wet runways if the tailwinds are 5 kt or more.

Conditions for Conduct of LAHSO

LAHSO will not be authorized:

- (a) if thunderstorms, turbulence, wind shear or other conditions exist that would adversely affect the restricted aircraft's ability to hold short after landing;
- (b) when an RSC NOTAM indicates that a runway is wet or has contamination present;
- (c) when weather reports indicate that precipitation is occurring; or
- (d) any time precipitation is observed by ATS personnel or reported by an aircraft.

LAHSO may be carried out under the following conditions:

- (a) the LDA, measured from the threshold or displaced threshold to 200 ft short of the nearest edge of the runway being intersected must be published in the CAP and in the CFS. ATC shall also broadcast LAHSO advisories, including LDAs, through an ATIS or voice advisory, well in advance of the final approach descent;
- (b) the weather minima of no less than:
 - (i) 1000-ft ceiling, and
 - (ii) 3 SM visibility.
- (c) a maximum of:
 - (i) 25 kt crosswind, and
 - (ii) 5 kt tailwind.
- (d) runway must be dry for LAHSO to be carried out.

When conducting LAHSO, pilots need to ensure that their aircraft can be stopped prior to the hold line of the intersecting runway specified by ATC, as depicted in Figure 4.4. The hold point for an intersecting runway is indicated by:

- (a) hold lines, which are perpendicular to the landing runway's centreline, 200 ft prior to the nearest edge of the intersecting runway, as shown in Figure 4.5;
- (b) red and white mandatory instruction signs, as shown in Figure 4.5; and
- (c) where provided, flashing land and hold short lights, as shown in Figure 4.5.

Figure 4.4—Landing Distance Available and Hold Lines for LAHSO

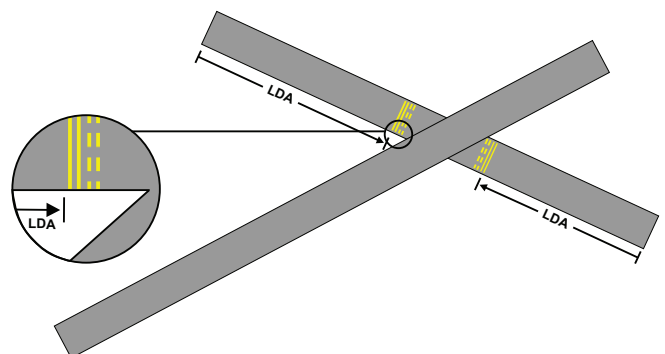
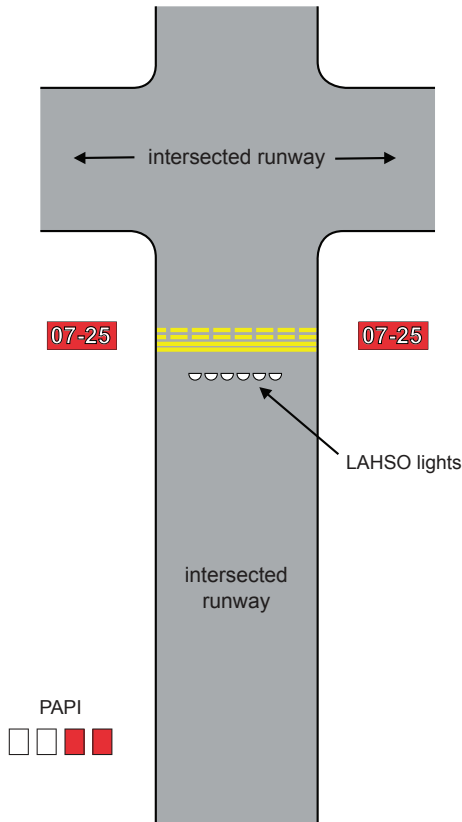

Figure 4.5—LAHSO Visual Aid Configuration



Additional details on runway markings and signage for LAHSO can be found in *Aerodrome Standards and Recommended Practices—Land Aerodromes* (TP 312, 5th edition);

For tactical ATC reasons, controllers may offer or approve a pilot request for the use of a runway for landing with a tailwind not exceeding 10 kt. Pilots should exercise caution and consider the impact of the tailwind on their OLD. If no allowance for the tailwind has been made in the calculation of the OLD, pilots should not accept the LAHSO clearance. For more information on the calculation of OLD, see AC 700-057—*Global Reporting Format (GRF) for Runway Surface Conditions: Guidance for Flight Operations, Appendix E*.

NOTE:

LAHSO are not not authorized if thunderstorms, turbulence, wind shear or other conditions exist that would adversely affect the restricted aircraft’s ability to hold short after landing.

Figure 4.6—Aircraft with Hold-short Clearance

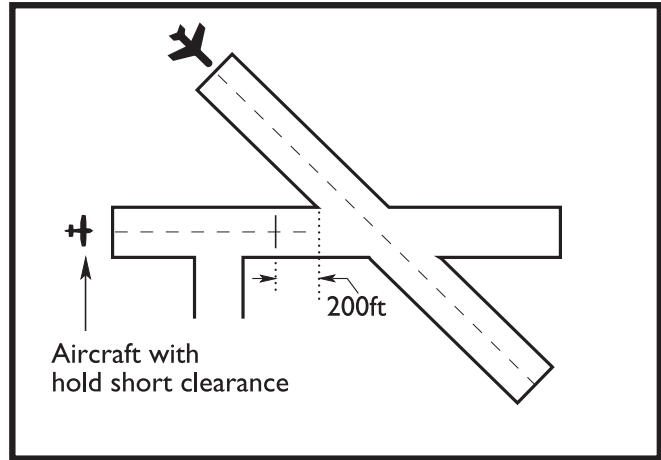

For simultaneous operations involving helicopters (Figure 4.7), if the arriving helicopter has a hold-short clearance, its point of landing is at least 700 ft from the centreline of the other runway.

Figure 4.7—Helicopter with Hold-short Clearance

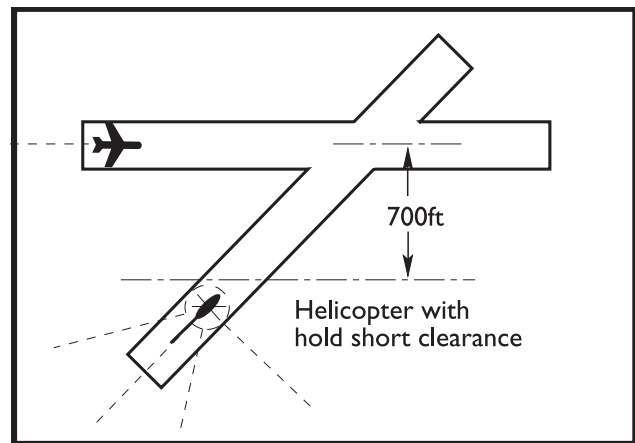

Aircraft Stop Groups

In order to facilitate ATC management of LAHSO, aircraft are categorized into groups according to their required stopping distances. ATC cannot clear an aircraft for LAHSO if the stopping distance required for the aircraft’s stop group is greater than the landing distance available (LDA).

The stopping distances for aircraft stop groups are indicated in Table 4.4.

Table 4.4—Stopping Distances on Dry per Aircraft Group

—	Dry Runway
Group 1	1 650 ft
Group 2	3 000 ft
Group 3	4 500 ft
Group 4	6 000 ft
Group 5	8 000 ft
Group 6	8 400 ft

These stopping distances are based on ISA conditions for sea-level runways. For higher airport elevations, the distances are adjusted for pressure altitude. An aircraft's grouping is such that its normal stopping distance is approximately 50% of the available stopping distance.

NOTE:

Pilots remain responsible for ensuring that the LDA is sufficient for the aircraft to safely come to a stop. For more information on the calculation of operational landing distance, see AC 700-057—*Global Reporting Format for Runway Surface Conditions: Guidance for Flight Operations, Appendix E*.

General Provisions

All pilots will be advised that simultaneous LAHSO are in progress.

Controllers will issue appropriate traffic information.

ATC must include specific directions to hold short of an intersecting runway (e.g. "Cleared to land Runway 27, hold short of Runway 36."). Pilots, in accepting the clearance, must read back "Cleared to land Runway 27, hold short of Runway 36." Having accepted the hold-short clearance, pilots are obligated to remain 200 ft short of the closest edge of the runway being intersected.

If, for any reason, a pilot is unsure of being able to comply with a hold-short clearance, the pilot must advise ATC immediately that they cannot accept the clearance; it is far better to be safe than sorry.

If a rejected landing becomes necessary after accepting a LAHSO clearance, the pilot must maintain safe separation from other aircraft and vehicles and notify ATC as soon as possible.

4.4.10 High Intensity Runway Operations (HIRO)

Several of Canada's airports rank among North America's busiest in total aircraft movements. HIRO, as a concept, have evolved from procedures developed by high density terminals in North America and Europe. It is intended to increase operational efficiency and maximize the capacity at those airports where it is employed through the use of disciplined procedures applied by both pilots and air traffic controllers. HIRO is intended to minimize the occurrence of overshoots that result from slow-rolling and/or slow-clearing aircraft and offers the prospective of reducing delays overall, both on the ground and in the air. In its fullest application, HIRO enables ATC to apply minimum spacing to aircraft on final approach to achieve maximum runway utilization.

The tactical objective of HIRO is to minimize runway occupancy times (ROT) for both arriving and departing aircraft, consistent with both safety and passenger comfort. Effective participation in HIRO results when the pilot of an arriving aircraft exits the runway expeditiously, allowing the following arriving aircraft to cross the threshold with a minimum time interval. In the case of an arrival and a subsequent departure, the arriving pilot clears the runway in a minimum ROT, permitting a departure before the next arrival crosses the threshold. The air traffic controller's objective in HIRO is to optimize approach spacing.

This can be best achieved when pilots reach and adhere to assigned speeds as soon as practicable.

Effective participation in HIRO is achieved by satisfying the following key elements.

Key elements for arrivals:

- (a) The pilot's objective should be to achieve minimum ROT, within the normally accepted landing and braking performance of the aircraft, by targeting the earliest suitable exit point and applying the right deceleration rate so that the aircraft leaves the runway as expeditiously as possible at the nominated exit.
- (b) The expected runway exit point to achieve minimum ROT should be nominated during approach briefing. It is better, in terms of ROT, to select an exit you know you can make, rather than choose an earlier one, miss it, and then roll slowly to the next available exit.
- (c) Upon landing, pilots should exit the runway without delay.
- (d) High-speed exits have specific maximum design speeds. These speeds may be available through the appropriate airport authority.

Key elements for departures:

- (a) On receipt of a line-up clearance, pilots should ensure that they are able to line up on the runway as soon as the preceding aircraft has commenced its takeoff roll.
- (b) ATC will expect aircraft to enter the runway at a suitable angle to quickly line-up on the centreline and, when possible, continue in to a rolling takeoff when cleared. Pilots should ensure that they are able to commence the takeoff roll immediately when a takeoff clearance is issued.
- (c) Aircraft that need to enter the runway at right angles, to backtrack, or to use the full length of the runway will require extra time on the runway. Therefore, pilots should notify ATC before arriving at the holding area so that the controller can re-sequence departures to provide the extra time.
- (d) Cockpit checks should be completed prior to line-up, and any checks requiring completion on the runway should be kept to a minimum. If extra time is required on the runway, ATC should be informed before the aircraft arrives at the holding area so that the controller can re-sequence departures to provide the extra time.

**4.5 Aircraft Operations—
Uncontrolled Aerodromes**

4.5.1 General

An uncontrolled aerodrome is an aerodrome without a control tower, or one where the tower is not in operation. There is no substitute for alertness while in the vicinity of an uncontrolled aerodrome. It is essential that pilots be aware of, and look out for, other traffic, and exchange traffic information when approaching or departing from an uncontrolled aerodrome, particularly since some aircraft may not have communication capability. To achieve the greatest degree of safety, it is essential

that all radio-equipped aircraft monitor a common designated frequency, such as the published MF or ATF, and follow the reporting procedures specified for use in an MF area, while operating on the manoeuvring area or flying within an MF area surrounding an uncontrolled aerodrome.

MF area means an area in the vicinity of an uncontrolled aerodrome for which an MF has been designated. The area within which MF procedures apply at a particular aerodrome is defined in the Aerodrome/Facility Directory section of the CFS, under the heading COMM. Normally, the MF area is a circle with a 5-NM radius capped at 3 000 ft above aerodrome elevation (AAE).

Pilots should revert to aerodrome traffic frequency (ATF) procedures when operating within an MF area outside of the specified hours of operations published in the CFS or by NOTAM.

At uncontrolled aerodromes without a published MF or ATF, the common frequency for the broadcast of aircraft position and the intentions of pilots flying in the vicinity of that aerodrome is 123.2 MHz.

At aerodromes within an MF area, traffic information may be exchanged by communicating with an FSS, CARS, UNICOM operator, vehicle operator, or by a broadcast transmission. The VCS in conjunction with AAS is normally provided at aerodromes served by an FSS. Some uncontrolled aerodromes are indirectly served by an FSS through an RCO and may provide RAAS. As flight service specialists may be located some distance from an aerodrome, it is essential that they be kept fully informed of both aircraft and vehicle activity.

Other aerodromes are designated as having an ATF. At some aerodromes with a control tower or FSS, an ATF is designated for use when the air traffic facility is closed. If a radio-equipped vehicle is present at ATF aerodromes, pilots can contact the vehicle operator directly on the ATF to ascertain that no vehicle-aircraft conflict exists. Operators of such radio-equipped vehicles will also provide pilots with any other available information on runway status and presence of other aircraft or vehicles on the runway.

There are some remote airports where a voice generator module (VGM) connected to an AWOS (or LWIS) continuously broadcasts weather information. An AWOS (or LWIS) broadcasts weather information that may differ from the aerodrome routine meteorological report (METAR) or aviation selected special weather report (SPECI) issued for the location. There may also be significant differences between broadcasts only a few minutes apart. Transport Canada recognizes that for any given site at any given time there can be only one official weather observation (METAR or SPECI), whether from a human observer or an automated station. As a result, it has been determined that although an AWOS (or LWIS) broadcast constitutes an additional source of accurate, up-to-the-minute weather information, it does not constitute an official weather observation (METAR or SPECI).

The wind and altimeter data obtained from an AWOS (or LWIS) via a VGM broadcast can be used to conduct an instrument approach. Therefore, at aerodromes where RAAS is provided

and where AWOS (or LWIS) weather information is also available via a VGM broadcast, the wind and altimeter data may be omitted from the RAAS if the pilot indicates in the initial call to the FSS that the weather information has already been obtained from the VGM broadcast. To avoid unnecessary frequency changes and to assist in reducing frequency congestion, it is desirable that pilots acquire this weather information prior to entering either the MF or ATF area and inform the flight service specialist that they have the wind and altimeter information. On start-up at such an aerodrome, it would be desirable to listen to the VGM broadcast prior to taxiing.

The flight service specialist will advise pilots of below-minima conditions reported in the current official METAR or SPECI. This will ensure a common reference for pilots and ATS personnel since IFR or SVFR authorization would then be required to operate within the control zone. Pilots will also be advised of any other significant weather conditions reported in current METAR, SPECI, SIGMET, AIRMET or PIREP, as appropriate, which may affect the safety of the flight. The flight service specialist will provide, upon request, the complete current METAR or SPECI for the location.

4.5.2 Traffic Circuit Procedures — Uncontrolled Aerodromes

The Canadian Aviation Regulations (CAR), which are applicable to operations at or in the vicinity of an aerodrome, are aligned with ICAO's International Standards and Recommended Practices (SARPs) documented in Annex 2. CAR 602.96(3) aligns with ICAO Annex 2, subchapter 3.2.5 by requiring the pilot-in-command of an aircraft operating at or in the vicinity of an uncontrolled aerodrome to:

- observe aerodrome traffic for the purpose of avoiding a collision;
- conform to or avoid the pattern of traffic formed by other aircraft in operation;
- make all turns to the left when operating within the aerodrome traffic circuit, except where right turns are specified by the Minister in the *Canada Flight Supplement* (CFS) or where otherwise authorized by the appropriate air traffic control unit; and
- where practicable, land and take off into the wind unless otherwise authorized by the appropriate air traffic control unit.

Additionally, CAR 602.96(3) requires the pilot-in-command to:

- if the aerodrome is an airport or heliport, comply with any airport or heliport operating restrictions specified by the Minister in the CFS or in a NOTAM.

CAR 602.96(4) requires pilots-in-command to not operate an aircraft at an altitude of less than 2,000 ft over an aerodrome except for the purpose of taking off or landing, unless otherwise authorized by the appropriate air traffic control unit or if the aircraft is operated pursuant to CAR 602.96(5). The traffic circuit consists of the crosswind leg, downwind leg, base leg and final approach leg. An aircraft operating in a traffic circuit, including

the midfield crosswind leg, immediately before joining the downwind leg or the 45° angle entry to the downwind leg, is considered to be an aircraft approaching to land at the aerodrome.

CAR 602.96(2) requires pilots to ensure that there is no likelihood of a collision with another aircraft or vehicle and that the aerodrome is suitable for their intended operation. Pilots are expected to observe other aircraft in the circuit and to conform to or avoid the pattern in use. The ICAO SARPs do not prescribe, nor does Transport Canada regulate, circuit entry. Furthermore, neither the ICAO SARPs nor the CARs address operating altitudes or the dimensions of the traffic circuit. Canadian aerodromes experience operations by a wide variety of aircraft categories and with a wide variety of performance capabilities including safe operating speeds, climb capabilities or other safety considerations, such as gliding distance. This complex mix may preclude some aircraft from operating at the same speed and over the same ground track as other aircraft established in the circuit pattern. All pilots are equally responsible for deconflicting with other aircraft at uncontrolled aerodromes. In planning how to fly the traffic circuit, pilots are reminded that CAR 602.01.1 requires that no person operate an aircraft in such a reckless or negligent manner as to endanger or be likely to endanger the life or property of any person.

The following recommendations apply to all aircraft operating at aerodromes where airport control service is not provided, except those aircraft following a standard instrument approach procedure. For procedures that apply to aircraft on a standard instrument approach, refer to RAC 9.0. Prior to joining a traffic circuit, all pilots should announce their intentions (see RAC 4.5.6). All turns shall be to the left while operating in the circuit, unless a right-hand circuit has been specified in the CFS.

Pilots operating aircraft under IFR or VFR are expected to approach and land on the active runway. The active runway is a runway that other aircraft are using or are intending to use for the purpose of landing or taking off. Should it be necessary for aircraft to approach to, land on or take off from a runway other than the active runway, it is expected that the appropriate communication between pilots and the ground station, as applicable, will take place to ensure there is no conflict with other traffic. Some pilots operating under VFR at many sites prefer to give commercial IFR and larger type of aircraft priority. This practice, however, is a personal airmanship courtesy, and it should be noted that these aircraft do not establish any priority over other aircraft operating VFR at that aerodrome.

Pilots are responsible to see and avoid other aircraft and to help others see and avoid their aircraft. Keep landing lights and strobes on. It is a best practice to always operate the transponder, even outside of transponder airspace, as some aircraft have collision avoidance systems that alert them of conflicting air traffic.

Clear and concise communications using standard phraseology are an important contributing factor to safety and an effective way to reduce the risk of incidents and occurrences. Pilots are reminded that the use of phrases such as “ANY TRAFFIC IN THE AREA, PLEASE ADVISE” are not standard phraseology and should not be used. Any traffic that is present at the time of a report should reply without prompting. Phraseology guides

are available through NAV CANADA at <<https://www.navcanada.ca/en/aeronautical-information/operational-guides.aspx>>. Pilots of aircraft flying the downwind leg at a different altitude than that flown by aeroplanes (normally 1 000 ft AAE), and pilots of aircraft flying a smaller or a larger circuit are encouraged to report their altitude in the circuit to the ground station associated with the MF (e.g., an FSS, an RCO through which RAAS is provided, a CARS or an Approach Unicom) or to broadcast their position and intentions for aerodromes without an MF or with an MF but without a ground station. Pilots should be aware that aerodromes without a MF do not require the use of two-way radio. Pilots must be especially vigilant for other aircraft while operating in the vicinity of uncontrolled aerodromes.

Figure 4.8—Standard Left-Hand Circuit Pattern

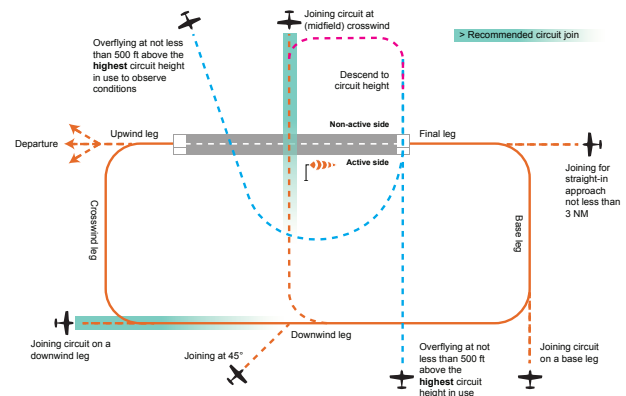

Unless a specific traffic circuit altitude is published in the CFS entry for the aerodrome or meteorological conditions dictate otherwise, it is recommended that:

1. Pilots of propeller-driven aeroplanes fly the circuit at 1 000 ft AAE.
2. Pilots of large and turbine-powered aeroplanes fly the circuit at 500 ft above the established circuit altitude (usually 1 500 ft AAE). All pilots should be aware that these aircraft usually operate at a higher speed than piston and electric engine light aeroplanes, have greater turning distances and fly larger circuits.
3. Pilots of rotorcraft either fly the circuit normally flown by aeroplanes or fly a circuit similar to aeroplanes, but at a lower altitude (500 ft AAE) and closer to the runway. Pilots of both helicopters and gyroplanes can be expected to practice power-off landings (autorotation), which involve a very steep approach angle and high descent rate (1 500 to 2 000 ft per minute). If specified in the CFS, this circuit may be on the opposite side of the runway from fixed-wing traffic when airspeed requires it or for practice autorotation landings.

Helicopters could choose to depart or arrive directly from the helipad on the airfield, the apron or a taxiway to avoid the fixed-wing circuit altogether. In such cases, the helicopter pilots must make clear radio calls describing their intentions and ensure they remain well clear of the circuit patterns altogether for either departure or arrival.

4. Pilots of slower, lower-performing aircraft, such as ultra-light aeroplanes, that are unable to conform to the pattern of traffic established by aircraft at the 1 000 ft AAE circuit fly a circuit at an altitude no higher than 500 ft below and inside the standard circuit established for the aerodrome. The pilot may vary the size of the traffic pattern depending on their aircraft's performance characteristics. If established in the CFS, an aerodrome with a dedicated landing area for ultra-light aeroplanes may have a lower traffic pattern parallel to the standard circuit, with turns in the opposite direction. All pilots should be aware that some ultra-light aeroplanes fly significantly slower than many other aircraft, exhibit steep takeoff and approach angles and make turns near the end of the runway to clear the area expediently.
5. Glider pilots typically join the circuit on the downwind leg but may be modified to suit conditions. Gliders typically operate on the downwind leg between 500 to 1 000 ft AAE, and fly a diagonal leg between the downwind and base leg. If specified in the CFS, this circuit may be on the opposite side of the runway from powered aircraft traffic. Pilots of powered aircraft are reminded that gliders are usually unable to maintain altitude in a circuit and that, in accordance with CAR 602.19, power-driven, heavier-than-air aircraft must give way to gliders. Gliders typically fly a steeper final approach glidepath (approximately 8 degrees). If a glider operating area is established to one side of a powered-aircraft runway, this operating area will usually be on the same side as the glider circuit.
6. Balloons have the right of way over all other aircraft categories and do not follow a standard circuit.
7. If a right-hand circuit is required in accordance with CAR 602.96, perform circuit procedures opposite to the depiction in the standard left-hand circuit diagram.

Figure 4.9—Standard Circuit heights

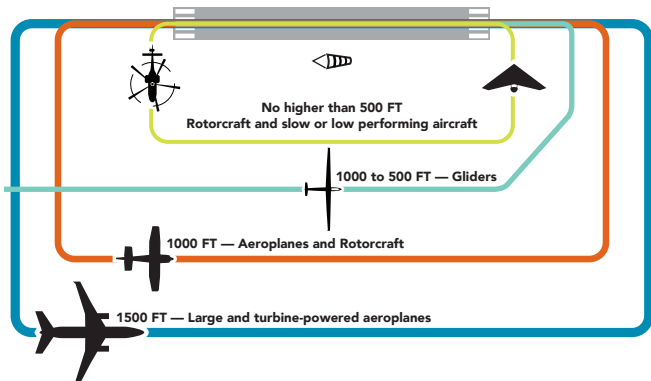

Joining the Circuit

Landing and takeoff should be accomplished on the runway most aligned into the wind as possible or on a runway parallel to it. However, the pilot has the final authority and is responsible for the safe operation of the aircraft, and another runway may be used if it is determined to be necessary in the interest of safety.

Unless otherwise specified or required by the applicable distance-from-cloud criteria, powered aircraft should approach the traffic circuit from the non-active side. Alternatively, if the pilot has ascertained that there will be no conflict with other traffic entering the circuit or established within it, the pilot could also join the circuit on the downwind leg (Figure 4.8). When joining from the non-active side, the pilot should plan the descent to cross the runway in level flight at circuit altitude and maintain that altitude until further descent is required for landing. Straight-in approaches are discouraged whenever there are other aircraft in the traffic circuit, as it may cause a conflict with other aircraft in the circuit and increase the risk of a mid-air collision.

If it is necessary for an aircraft to cross the aerodrome before joining the circuit, it is recommended that the crossover be accomplished at least 500 ft above the highest circuit altitude in use.

All descents should be made on the non-active side or well clear of the circuit pattern.

Figure 4.10—Recommended circuit join from the active side

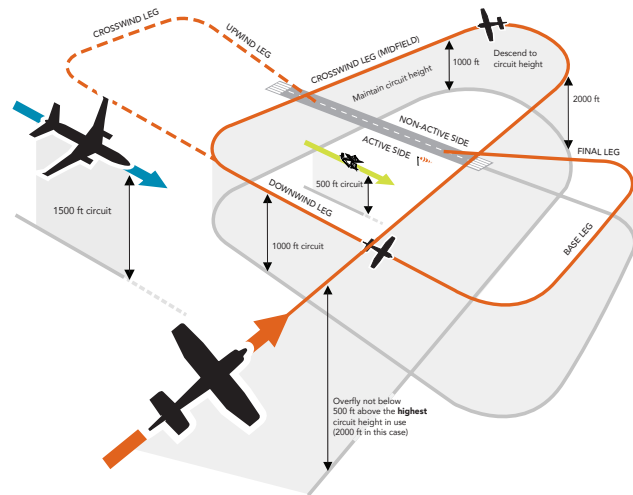

For aerodromes not within an MF area: Where no MF procedures are in effect, powered aircraft should approach the traffic circuit from the non-active side. Alternatively, once the pilot has ascertained that there will be no conflict with other traffic entering the circuit or established within it, the pilot could join the circuit on the downwind leg (Figure 4.8). Straight-in approaches are discouraged whenever there are other aircraft in the traffic circuit, as it may cause a conflict with other aircraft in the circuit and increase the risk of a mid-air collision.

For aerodromes within an MF area when airport advisory information is available: Aircraft could join the circuit pattern straight-in or at a 45° angle to the downwind leg or straight-in to the base or final legs (Figure 4.1). Pilots must be alert both to other VFR traffic entering the circuit at these positions and to IFR straight-in or circling approaches.

For aerodromes within an MF area when airport advisory information is not available: Powered aircraft should normally approach the traffic circuit from the non-active side. Alternatively, once the pilot has ascertained that there will be no conflict with other traffic entering the circuit or established within it, the pilot could join the circuit on the downwind leg (Figure 4.8), or as in subparagraph (f) above. Straight-in approaches are discouraged whenever there are other aircraft in the traffic circuit, as it may cause a conflict with other aircraft in the circuit and increase the risk of a mid-air collision.

NOTE:

When an uncontrolled aerodrome lies within an MF area, the pilot must follow the MF reporting procedures set out in CARs 602.97 to 602.103, inclusive (see RAC 4.5.4 and 4.5.7.)

Continuous Circuits

Aircraft performing a series of circuits and landings should, after each takeoff, commence the turn to the crosswind leg beyond the departure end of the runway and within 300 ft of the circuit altitude and reach circuit altitude before joining the downwind leg.

Departing the Circuit or Aerodrome

Aircraft departing the circuit or aerodrome should climb straight ahead on the runway heading up to the circuit traffic altitude before commencing a turn in any direction to an en route heading. A turn back toward the circuit or aerodrome should not be initiated until the aircraft is at least 500 ft above the highest circuit altitude in use.

NOTE:

Aircraft towing gliders will often have unusual or varied departure tracks to keep the gliders they are towing within gliding distance of the departure aerodrome in the event of a tow rope break. Pilots of other power-driven aircraft are reminded that CAR 602.19 requires them to give way to aircraft that are seen to be towing gliders or other objects or carrying a slung load.

NOTE:

ATS sites without tower control services differ slightly in the United States and may differ in other countries. Canadian pilots are recommended to consult the U.S. *Aeronautical Information Manual* before operating at U.S. non-towered airports.

4.5.3 Helicopter Operations

Pilots of helicopters at uncontrolled aerodromes are urged to avoid air taxiing or low flying across runways and taxiway areas where risk of collision with unseen aircraft or vehicles exists.

In addition to maintaining a sharp look-out and practising good airmanship, pilots should avoid ground or air taxiing and hovering where blown dust, sand, gravel or wake turbulence could prove hazardous to other aircraft, or when debris could be blown onto paved surfaces.

4.5.4 Mandatory Frequency (MF)

Transport Canada has designated a Mandatory Frequency (MF) for use at selected uncontrolled aerodromes, or aerodromes that are uncontrolled between certain hours. Aircraft operating within the area in which the MF is applicable (MF area), on the ground or in the air, shall be equipped with a functioning radio capable of maintaining two-way communication. Reporting procedures shall be followed, as specified in CARs 602.97 to 602.103 inclusive.

An MF area will be established at an aerodrome if the traffic volume and mix of aircraft traffic at that aerodrome is such that there would be a safety benefit derived from implementing MF procedures. There may or may not be a ground station in operation at the aerodrome for which the MF area has been established. When a ground station is in operation, for example, an FSS, an RCO through which RAAS is provided, a CARS, or an Approach UNICOM, then all aircraft reports that are required for operating within, and prior to entering an MF area, shall be directed to the ground station. However, when the ground station is not in operation, then all aircraft reports that are required for operating within and prior to entering an MF area shall be broadcast. The MF will normally be the frequency of the ground station which provides the air traffic advisory services for the aerodrome. For the aerodromes with an MF, the specific frequency, distance and altitude within which MF procedures apply will be published in the CFS.

Examples:

MF—rdo 122.2 5 NM 3100 ASL

MF—UNICOM (AU) ltd hrs O/T tfc 122.75 5 NM 3100 ASL

4.5.5 Aerodrome Traffic Frequency (ATF)

An Aerodrome Traffic Frequency (ATF) is normally designated for active uncontrolled aerodromes that do not meet the criteria listed in RAC 4.5.4 for an MF. The ATF is established to ensure that all radio-equipped aircraft operating on the ground or within the area are listening on a common frequency and following common reporting procedures. The ATF will normally be the frequency of the UNICOM where one exists or 123.2 MHz where a UNICOM does not exist. Trained vehicle operators who possess a valid radiotelephone licence and authorized to do so, can communicate with pilots using two-way communication on the ATF and provide information such as:

- (a) position of vehicles on the manoeuvring area;
- (b) position of other aircraft on the manoeuvring area; and
- (c) runway condition, if known.

The specific frequency, distance and altitude within which use of the ATF is required will be published in the CFS.

Example:

ATF – tfc 123.2 5 NM 5500 ASL

Personnel providing Approach UNICOM service, can also advise pilots on the ATF of the runway condition and position of vehicles or aircraft on the manoeuvring area.

NOTE:

Pilots may be able to communicate with either the UNICOM or the vehicle operator if radio-equipped, and coordinate their arrival or departure while using normal vigilance to ensure safe operations. When communications cannot be established (no reply or NORDDO) or the status of the runway is unknown, it is the pilot's responsibility to visually ascertain the runway condition before landing or taking off.

The designation of an ATF is not limited to aerodromes only. An ATF may also be designated for use in certain areas—other than the area immediately surrounding an aerodrome—where VFR traffic activity is high, and there is a safety benefit to ensuring that all traffic monitor the same frequency. For example, an ATF area could be established along a frequently flown corridor between two uncontrolled aerodromes. All aircraft operating within the area, below a certain altitude, would be requested to monitor and report intentions on one frequency. When such an area is designated, it will be specified in an *AIP Canada* Supplement or in the CFS.

4.5.6 Use of Mandatory Frequency (MF) and Aerodrome Traffic Frequency (ATF)

When operating in accordance with VFR, or in accordance with IFR but in VMC, pilots have sole responsibility for seeing and avoiding other aircraft. Aural and visual alertness are required to enhance safety of flight in the vicinity of uncontrolled aerodromes. At uncontrolled aerodromes for which an MF or ATF has been designated, certain reports shall be made by all radio-equipped aircraft.

NOTE:

Pilots operating VFR en route in uncontrolled airspace or VFR on an airway should continuously monitor 126.7 MHz when not communicating on the MF or ATF.

Reports on either the MF or ATF have three formats:

- (a) a directed transmission made to a ground station;
- (b) a directed transmission made to a vehicle operator on the ATF; or
- (c) a broadcast transmission that is not directed to any particular receiving station.

Whenever the CFS indicates that reports are to be made to a ground station, the initial transmission should be made to the station. To assist in reducing frequency congestion, pilots are encouraged to use the phrase “HAVE NUMBERS” on the initial call to a ground station (arrival or departure) to indicate that they have received runway, wind and altimeter information from the previous aerodrome advisory. When operating outside an MF area, and when frequency congestion prevents pilots from making their mandatory calls, it is their responsibility to remain clear of the MF area until contact can be established with the FSS. If operating inside an MF area, the pilot should continue as stated in previous radio transmissions.

Pilot: *FREDERICTON RADIO, PIPER FOXTROT X-RAY YANKEE ZULU. WE HAVE THE NUMBERS, SIX MILES SOUTHWEST AT THREE THOUSAND FIVE HUNDRED VFR. INBOUND FOR LANDING.*

Should there be no acknowledgement of a directed transmission to a ground station or a vehicle operator, reports shall be made in the broadcast format unless the ground station or vehicle operator subsequently establishes two-way contact, in which case pilots shall resume communicating by directed transmission.

Examples:

Directed: *FREDERICTON RADIO, THIS IS PIPER FOXTROT X-RAY YANKEE ZULU BEACON INBOUND LANDING RUNWAY EIGHTEEN.*

or,

FREDERICTON VEHICLES, THIS IS PIPER FOXTROT X-RAY YANKEE ZULU...

Broadcast: *FREDERICTON TRAFFIC, THIS IS PIPER FOXTROT X-RAY YANKEE ZULU...*

4.5.7 Visual Flight Rules (VFR) Communication Procedures at Uncontrolled Aerodromes with Mandatory Frequency (MF) and Aerodrome Traffic Frequency (ATF) Areas

Radio-equipped Aircraft: The following reporting procedures shall be followed by the pilot-in-command of radio-equipped aircraft at uncontrolled aerodromes within an MF area and should also be followed by the pilot-in-command at aerodromes with an ATF:

- (a) *Listening Watch and Local Flying* [CAR 602.97 (2)] Maintain a listening watch on the mandatory frequency specified for use in the MF area. This should apply to ATF areas as well.
- (b) *Before Entering Manoeuvring Area* [(CAR 602.99)] Report the pilot-in-command's intentions before entering the manoeuvring area.
- (c) *Departure* (CAR 602.100)
 - (i) Before moving onto the take-off surface, report the pilot-in-command's departure intentions on the MF or ATF frequency. If a delay is encountered, broadcast intentions and expected length of delay, then rebroadcast departure intentions prior to moving onto the take-off surface;
 - (ii) Before takeoff, ascertain by radio on the MF or ATF frequency and by visual observation that there is no likelihood of collision with another aircraft or a vehicle during takeoff; and,
 - (iii) After takeoff, report departing from the aerodrome traffic circuit, and maintain a listening watch on the MF or ATF frequency until clear of the area.
- (d) *Arrival* (CAR 602.101)
 - (i) Report before entering the MF area and, where circumstances permit, shall do so at least five minutes before entering the area, giving the aircraft's position, altitude and estimated time of landing and the pilot-in-command's arrival procedure intentions;
 - (ii) Report when joining the aerodrome traffic circuit, giving the aircraft's position in the circuit;
 - (iii) Report when on downwind leg, if applicable;
 - (iv) Report when on final approach; and
 - (v) Report when clear of the surface on which the aircraft has landed.
- (e) *Continuous Circuits* (CAR 602.102)
 - (i) Report when joining the downwind leg of the circuit;
 - (ii) Report when on final approach; stating the pilot-in-command's intentions; and,
 - (iii) Report when clear of the surface on which the aircraft has landed.

(f) *Flying Through an MF Area* (CAR 602.103)

- (i) Report before entering the MF or ATF area and, where circumstances permit, shall do so at least five minutes before entering the area, giving the aircraft's position and altitude and the pilot-in-command's intentions; and,
- (ii) Report when clear of the MF or ATF area.

NOTE:

In the interest of minimizing possible conflict with local traffic and minimizing radio congestion on the MF or ATF, pilots of en-route VFR aircraft should avoid passing through MF or ATF areas.

NORDO: NORDO aircraft will only be included as traffic to other aircraft and ground traffic as follows:

- (a) **Arrival:** from five minutes before the ETA until ten minutes after the ETA, and
- (b) **Departure:** from just prior to the aircraft departing until ten minutes after the departure, or until the aircraft is observed/reported clear of the MF area.

4.5.8 Aircraft Without Two-Way Radio (No Radio [NORDO]/Receiver Only [RONLY])

4.5.8.1 Prior Arrangements

Aircraft without a functioning two-way radio may operate on the manoeuvring area or within the MF area associated with an uncontrolled aerodrome, provided:

- (a) an FSS, a CARS, or an RCO through which RAAS is provided, is located at the aerodrome and is operating at the time proposed for the operation; and
- (b) prior arrangements have been made, by telephone or in person, with the appropriate agency, FSS, CARS, or in the case of a RAAS, the FSS.

NOTES:

1. Prior arrangements for an AAS location: phone the "emergency only" number listed in the CFS under COMM / RADIO for the FSS serving the AAS location.
2. Prior arrangements for a RAAS location: the FSS or FIC serving a RAAS location is shown in the CFS under COMM / RCO for the RAAS location.
 - (a) If an FSS serves the RAAS location: phone the "emergency only" number listed in the CFS under COMM / RADIO for the FSS serving the RAAS location; or
 - (b) If a FIC serves the RAAS location: phone the number listed in the CFS under FLT PLAN / FIC for the RAAS location.

When a pilot-in-command intends to operate at an uncontrolled aerodrome for which an MF has been designated, the pilot-in-command shall ascertain by visual observations that no other aircraft or vehicle is likely to come into conflict with the aircraft

during takeoff or landing.

Pilots of NORDO/ROONLY aircraft must be extremely vigilant when operating at either controlled or uncontrolled aerodromes and ensure through prior arrangements that other aircraft and vehicles will be informed of their presence within the area.

4.5.8.2 Traffic Circuits - No Radio [NORDO]/Receiver Only [ROONLY]

When approaching an aerodrome, pilots of NORDO/ROONLY aircraft shall enter the circuit as illustrated in Figure 4.8 and ensure that the aircraft completes at least two sides of a rectangular circuit before turning on to the final approach path.

4.5.8.3 Receiver Only (ROONLY)

When operating an aircraft equipped with a VHF receiver capable of receiving transmissions on the MF, pilots shall maintain a listening watch on the MF when operating on the manoeuvring area or within the MF area.

4.6 Helicopter Operations at Controlled Airports

Two modes of helicopter airborne taxiing operations have been defined to accommodate the movement of helicopters at aerodromes: these are HOVER TAXI and AIR TAXI.

In addition to maintaining a sharp lookout and practising good airmanship, pilots should avoid hover or air taxiing and hovering where blown dust, sand, gravel, or wake turbulence could prove hazardous to other aircraft or when debris could be blown onto paved surfaces.

Hover taxi is the movement of a helicopter above the surface of an aerodrome, in ground effect, and at airspeeds less than approximately 20 knots of indicated airspeed (KIAS). The actual height may vary; some helicopters require hover taxi above 25 ft above ground level (AGL) to reduce ground effect turbulence or up to approximately 125 ft AGL to provide clearance for cargo sling loads.

Air taxi is the movement of a helicopter above the surface of an aerodrome normally below 100 ft AGL. The pilot is solely responsible for selecting an appropriate height and airspeed for the operation being conducted and consistent with existing traffic and weather conditions. Pilots are cautioned of the possibility of the loss of visual references when conducting air taxi operations. Because of the greater operating flexibility, an air taxi clearance at controlled aerodromes is to be expected unless traffic conditions will not permit this mode of operation.

When a helicopter is wheel-equipped and the pilot wishes to taxi on the ground, air traffic control (ATC) should be informed when clearance is requested.

NOTE:

Helicopter pilots are reminded that aircraft, vehicle and personnel movements are not controlled on airport aprons, and that caution must be exercised at all times during any surface movement, hover or air taxiing.

4.7 Published VFR Routes and VFR Checkpoints

Visual flight rules (VFR) routes and/or VFR checkpoints may be published to help enhance safety of VFR pilots when transiting busier volumes of airspace.

Published VFR routes recommend ways to enter, exit or transit through congested areas. Following the published routes safely integrates VFR aircraft with other operations that may take place in the same airspace, such as instrument flight rules (IFR) flight and instrument approach procedures.

A published VFR checkpoint is a geographical reference point with a pronounceable name that is used for communicating the position of an aircraft in flight. Normally, the name is shared with the geographic feature it is established over. VFR checkpoints can be published along VFR routes or can be published on their own. Providing position reports in relation to published VFR checkpoints supports shared situational awareness between all concerned aircraft and with air traffic services (ATS) personnel. Published VFR checkpoints are also assigned five-letter identifiers beginning with the letters “VC” to facilitate their use in global navigation satellite system (GNSS) equipped aircraft with navigation databases.

VFR pilots are encouraged to refer to VFR Terminal Procedures Charts (VTPC) or VFR Terminal Area (VTA) charts to determine where VFR routes and/or VFR checkpoints are published and to follow the published recommendations whenever safely possible. VTPC and VTA charts use the following symbols to depict the routes and checkpoints:

Figure 4.11—VTPC and VTA chart symbols to depict the routes and checkpoints



The following is an example VTPC with published unidirectional fixed wing VFR routes helping to organize entry and exit from the MONTRÉAL/MET control zone and a number of VFR checkpoints:

5.0 Visual Flight Rules (VFR) En Route Procedures

Figure 4.12—Example VTPC with published unidirectional fixed wing VFR routes

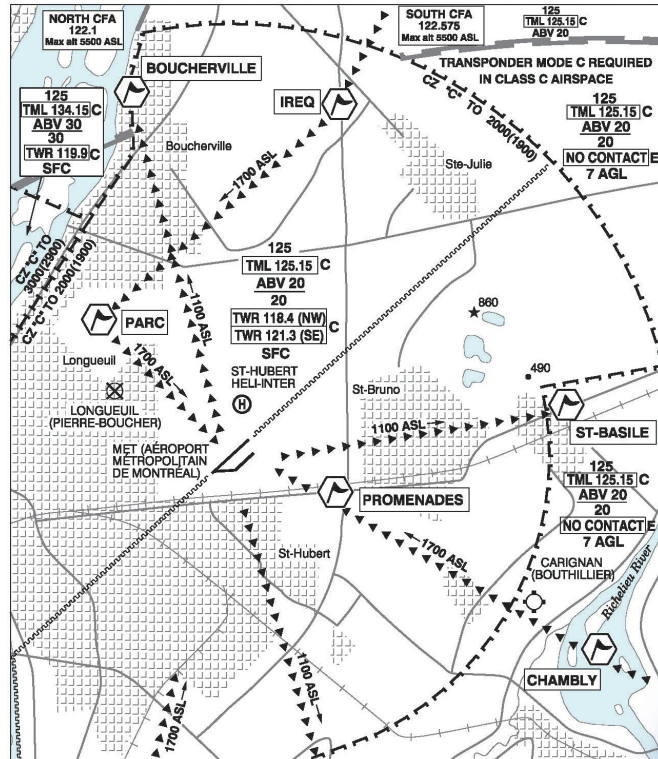

NOM	IDENT	LAT/LONG
AUTOROUTE 10 / RIVIERE L'ACADIE	VCACD	N45° 24' 28" W073° 22' 06"
BOUCHERVILLE	VCBSV	N45° 36' 48" W073° 27' 24"
CARRIERE VARENNES	VCCVS	N45° 39' 55" W073° 20' 08"
CHAMBLY	VCBCY	N45° 27' 40" W073° 16' 38"
IREQ	VCIRE	N45° 36' 46" W073° 23' 02"
PARC	VCPRK	N45° 33' 05" W073° 28' 11"
PROMENADES	VCPMM	N45° 30' 19" W073° 22' 42"
ST-BASILE	VCSTB	N45° 31' 36" W073° 17' 20"
ST-PHILIPPE	VCLPR	N45° 21' 10" W073° 28' 29"

DEPARTURES
- All rwys, unless specified by ATC, not above 1100 ASL until outside the zone

ARRIVALS
Follow arrival routes, unless otherwise specified by ATC:
CHAMBLY arrival
- 24L: proceed to PROMENADES, join mid-left downwind, not below 1700 ASL
- 06R: proceed to PROMENADES, join mid-right downwind, not below 1700 ASL
St-PHILIPPE arrival
- 24L: proceed to PROMENADES, join left downwind, not below 1700 ASL
- 06R: join straight-in approach, not below 1700 ASL
VARENNES arrival
- 24R: proceed to IREQ, then to PARC, join mid-right downwind, not below 1700 ASL
- 06L: proceed to IREQ, then to PARC, join mid-left downwind, not below 1700 ASL

NOTE:
Pilots of gyroplanes are encouraged to follow the fixed wing VFR routes.

5.1 Monitoring, Broadcasting on 126.7 MHz and Position Reporting En Route

Pilots operating VFR en route in uncontrolled airspace when not communicating on an MF, or an ATF, or VFR on an airway should continuously monitor 126.7 MHz and whenever practicable, broadcast their identification, position, altitude and intentions on this frequency to alert other VFR or IFR aircraft that may be in the vicinity. Although it is not mandatory to monitor 126.7 MHz and broadcast reports during VFR or VFR-OTT flights, pilots are encouraged to do so for their own protection. Pilots are encouraged to make position reports on the appropriate FISE frequency to a FIC where they are recorded by the flight service specialist and are immediately available in the event of SAR action. The following reporting format is recommended:

1. Identification
2. Position
3. Time over
4. Altitude
5. VFR / VFR-OTT
6. Destination

Example:

Pilot: *QUEBEC RADIO, THIS IS CESSNA GOLF INDIA GOLF BRAVO ON THE GATINEAU R-C-O, VFR (or VFR OVER-THE-TOP) POSITION REPORT.*

Radio: *CESSNA GOLF INDIA GOLF BRAVO, QUEBEC RADIO, GO AHEAD.*

Pilot: *QUEBEC RADIO, GOLF INDIA GOLF BRAVO, BY OTTAWA AT FIVE EIGHT, FOUR THOUSAND FIVE HUNDRED, VFR (or VFR OVER-THE-TOP), DESTINATION SUDBURY.*

NOTES:

1. As shown in the example, it is important on initial contact that the pilot alerts the FIC to the fact that it is a VFR or VFR-OTT position report and indicates the name of the location of the RCO followed by the letters R-C-O in a non-phonetic form.
2. The ETA destination or next reporting point may be included.
3. Under certain conditions position reports are required prior to entering the ADIZ when operating on a DVFR flight plan or a defence flight itinerary.

5.2 Acknowledgement of Clearances

Pilots of VFR flights shall read back the text of an ATC clearance when requested by an ATC unit.

5.3 Altitudes and Flight Levels — Visual Flight Rules (VFR)

Aircraft shall be operated at altitudes or flight levels appropriate to the direction of flight when in level cruising flight above 3 000 feet AGL.

5.4 Minimum Altitudes—Visual Flight Rules (VFR) (*Canadian Aviation Regulations* [CARs] 602.14 and 602.15)

Minimum Altitudes and Distances

602.14

- (1) [Repealed, SOR/2002-447, s. 2]
- (2) Except where conducting a takeoff, approach or landing or where permitted under Section 602.15, no person shall operate an aircraft
 - (a) over a built-up area or over an open-air assembly of persons unless the aircraft is operated at an altitude from which, in the event of an emergency necessitating an immediate landing, it would be possible to land the aircraft without creating a hazard to persons or property on the surface, and, in any case, at an altitude that is not lower than
 - (i) for aeroplanes, 1,000 feet above the highest obstacle located within a horizontal distance of 2,000 feet from the aeroplane,
 - (ii) for balloons, 500 feet above the highest obstacle located within a horizontal distance of 500 feet from the balloon, or
 - (iii) for an aircraft other than an aeroplane or a balloon, 1,000 feet above the highest obstacle located within a horizontal distance of 500 feet from the aircraft; and
 - (b) in circumstances other than those referred to in paragraph (a), at a distance less than 500 feet from any person, vessel, vehicle or structure.

Permissible Low-Altitude Flight

602.15

- (1) A person may operate an aircraft at altitudes and distances less than those specified in subsection 602.14(2) where the aircraft is operated at altitudes and distances that are no less than necessary for the purposes of the operation in which the aircraft is engaged, the aircraft is operated without creating a hazard to persons or property on the surface and the aircraft is operated
 - (a) for the purpose of a police operation that is conducted in the service of a police authority;
 - (b) for the purpose of saving human life;
 - (c) for fire-fighting or air ambulance operations;
 - (d) for the purpose of the administration of the Fisheries Act or the Coastal Fisheries Protection Act;
 - (e) for the purpose of the administration of the national or provincial parks; or
 - (f) for the purpose of flight inspection.
- (2) A person may operate an aircraft, to the extent necessary for the purpose of the operation in which the aircraft is engaged, at altitudes and distances less than those set out in
 - (a) paragraph 602.14(2)(a), where operation of the aircraft is authorized under Subpart 3 or Section 702.22; or
 - (b) paragraph 602.14(2)(b), where the aircraft is operated without creating a hazard to persons or property on the surface and the aircraft is operated for the purpose of
 - (i) aerial application or aerial inspection,
 - (ii) aerial photography conducted by the holder of an air operator certificate,
 - (iii) helicopter external load operations, or
 - (iv) flight training conducted by or under the supervision of a qualified flight instructor.

NOTE:

The hazards of low flying cannot be overemphasized. Refer to AIR 2.4 for more information on the risks and hazards of low flying.

5.5 Minimum Altitudes — Overflying Aerodromes [*Canadian Aviation Regulations* [CARs] 602.96(4)and(5)]

602.96

- (4) Unless otherwise authorized by the appropriate air traffic control unit, no pilot-in-command shall operate an aircraft at a height of less than 2 000 feet over an aerodrome except for the purpose of landing or taking off or if the aircraft is operated pursuant to subsection (5).

602.96

- (5) Where it is necessary for the purposes of the operation in which the aircraft is engaged, a pilot-in-command may operate an aircraft at less than 2 000 feet over an aerodrome, where it is being operated
- in the service of a police authority;
 - for the purpose of saving human life;
 - for fire-fighting or air ambulance operations;
 - for the purpose of the administration of the *Fisheries Act or the Fisheries Protection Act*;
 - for the purpose of the administration of the national or provincial parks;
 - for the purpose of flight inspection;
 - for the purpose of aerial application or aerial inspection;
 - for the purpose of highway or city traffic patrol;
 - for the purpose of aerial photography conducted by the holder of an air operator certificate;
 - for the purpose of helicopter external load operations; or
 - for the purpose of flight training conducted by the holder of a flight training unit operator certificate.

5.6 Controlled Visual Flight Rules (CVFR) Procedures

Pilots intending to fly CVFR shall file a flight plan and obtain an ATC clearance prior to entering Class B airspace. The ATC clearance will not normally be issued prior to takeoff unless the airspace within a control zone is Class B. The ATC clearance will normally be issued upon receipt of a position report filed by the pilot upon reaching the last 1 000 feet altitude below the base of Class B or before entering laterally. This procedure is intended to ensure that the radio equipment is operating and to remind the pilots that, while outside of Class B airspace, ATC separation is not provided and that they must maintain a vigilant watch for other traffic. The ATC clearance will contain the phrase “MAINTAIN (altitude) VFR”.

CVFR flights must be conducted in accordance with procedures designed for use by IFR flights, except when IFR weather conditions are encountered, the pilot of a CVFR flight must avoid such weather conditions. This should be accomplished by:

- requesting an amended ATC clearance which will enable the aircraft to remain in VFR weather conditions
- requesting an IFR clearance if the pilot has a valid instrument rating and the aircraft is equipped for IFR flight.
- request special VFR if within a control zone.

If unable to comply with the preceding, ensure that the aircraft is in VFR weather conditions at all times and leave Class B airspace horizontally or by descending. If the airspace is a control zone, land, at the aerodrome on which the control zone is based. In both cases, inform ATC as soon as possible of the action taken.

5.7 En route Air Traffic Service (ATS) Surveillance

When operating in areas where surveillance coverage exists, visual flight rules (VFR) flights with transponder-equipped aircraft may request air traffic service (ATS) surveillance traffic information. Air traffic control (ATC) may provide this information, traffic (or workload) permitting, depending on the classification of the airspace (see RAC 2.8).

The service is provided by the area control centre (ACC) or terminal control unit (TCU) responsible for instrument flight rules (IFR) control service in the area(s) concerned. The appropriate frequency for the controlling ATC unit may be found in the *Canada Flight Supplement (CFS)* (nearest controlled airport), en route (IFR) charts or by request to a flight information centre (FIC).

5.8 Visual Flight Rules (VFR) Operations Within Class C Airspace

The following are the basic procedures for entry into, and for operation within Class C airspace. Pilots should consult the applicable VTA chart for any additional procedures that may be required for that particular Class C airspace.

(a) Pilot Procedures

- Obtain ATIS information (when available) prior to contacting ATC.
- Contact ATC on VFR advisory frequency (depicted on VTA charts) prior to entry into Class C airspace and provide the following information:
 - aircraft type and identification,
 - position (preferably over a VFR checkpoint depicted on the VTA chart or a bearing and distance from it, otherwise another prominent reporting point or a VOR radial or VOR/DME fix),
 - altitude,
 - destination and route, and
 - transponder code (if transponder equipped), and ATIS (code) received.
- Comply with ATC instructions received. Any ATC instruction issued to VFR flights is based on the firm understanding that a pilot will advise ATC immediately if compliance with the instructions would result in not being able to maintain adequate terrain or obstacle clearance, or to maintain flight in accordance with VFR. If so advised, ATC will issue alternate instructions.

(b) ATC Procedures

- Identify the aircraft with ATS surveillance. (Pilots may be required to report over additional fixes, or squawk ident on their transponder.) The provision of an effective ATS surveillance service is dependent upon communications equipment capabilities and the adequacy of the surveillance-displayed information. In the latter case, it may be difficult to maintain identification of aircraft which are not

operating on specific tracks or routes (i.e. sightseeing, local training flights, etc.), and pilots will be advised when ATS surveillance service cannot be provided.

- (ii) Issue landing information on initial contact or shortly thereafter unless the pilot states that the appropriate ATIS information has been received.
- (iii) Provide the aircraft with routing instructions or vectors whenever necessary. The pilot will be informed when vectoring is discontinued except when transferred to a tower. Occasionally, an aircraft may be held at established fixes within Class C airspace to await a position in the landing sequence.
- (iv) Issue traffic information when two or more aircraft are held at the same fix, or whenever in the controller's judgement an ATS surveillance-observed target might constitute a hazard to the aircraft concerned.
- (v) When required, conflict resolution will be provided between IFR and VFR aircraft, and upon request, between VFR aircraft.
- (vi) Visual separation may be effected when the pilot reports sighting a preceding aircraft and is instructed to follow it.
- (vii) Inform the pilot when ATS surveillance service is terminated, except when the aircraft has been transferred to a tower.

6.0 Instrument Flight Rules (IFR) — General

6.1 Air Traffic Control (ATC) Clearance

Air traffic control (ATC) clearance shall be obtained before takeoff from any point within controlled airspace or before entering controlled airspace for flight under instrument flight rules (IFR) or during instrument meteorological conditions (IMC).

According to *Canadian Aviation Regulation* (CAR) 602.31, clearance received by a pilot must be read back to the controller, except in certain circumstances. When clearance is received on the ground before departure from a controlled aerodrome and a standard instrument departure (SID) is included in the clearance, the pilot only needs to acknowledge receipt of the clearance by repeating the aircraft call sign and the transponder code that was assigned. If there is an amendment to the altitude contained in the SID, that altitude shall also be read back. Whenever the controller requests a full readback, the pilot shall comply. Also, the pilot may, at any time, read back a clearance in full to seek clarification.

Whenever clearance is received and accepted by the pilot, the pilot shall comply with it. If the clearance cannot be accepted, the pilot shall immediately notify ATC because simple acknowledgement of the clearance will be interpreted by the controller as acceptance.

Pilots shall not deviate from a clearance except in an emergency that necessitates immediate action, or in order to respond to an

airborne collision avoidance system/traffic alert and collision avoidance system (ACAS/TCAS) resolution advisory (RA), a warning from a ground proximity warning system (GPWS), or a warning from an aircraft wind shear (WS) detection and warning system (see MET 2.3). In these cases, the pilot shall inform ATC as soon as possible and obtain an amended clearance (as per CAR 602.31).

6.2 Instrument Flight Rules (IFR) Flights in Visual Meteorological Conditions (VMC)

A pilot may elect to conduct a flight in accordance with IFR in VMC. Flights operating in accordance with IFR shall continue in accordance with IFR, regardless of weather conditions. An IFR clearance provides separation between IFR aircraft in controlled airspace only. Pilots operating IFR must be aware of the need to provide their own visual separation from VFR aircraft when operating in VMC and from any other aircraft when operating in uncontrolled airspace.

A pilot may cancel IFR, or close the IFR flight plan, provided the aircraft is operating in VMC, is outside Class A or B airspace, and it is expected that the flight will not return to IMC. If the pilot closes the IFR flight plan or cancels IFR, ATC will discontinue the provision of IFR control service.

Refer to RAC Closing a Flight Plan, for information on the requirement to submit an arrival report and on the provision of alerting service upon closure or cancellation of IFR. Provided the destination remains the same, a pilot may change an IFR flight plan to a VFR flight plan without having to file a new flight plan. ATC will, however, confirm the aircraft's destination and ETA and obtain a search and rescue time from the pilot.

6.2.1 Instrument Flight Rules (IFR) Clearance with Visual Flight Rules (VFR) Restrictions

ATC may issue an IFR clearance for an aircraft to depart, climb or descend VFR until a specified time, altitude, or location provided

- (a) the pilot requests it;
- (b) the aircraft is outside Class A airspace;
- (c) the aircraft is within Class B airspace at or below 12 500 ft ASL or within Class C, D or E airspace; and
- (d) the weather conditions permit.

Pilots are reminded that during such a VFR restriction they must provide their own separation, including wake turbulence separation, from other IFR aircraft as well as from the VFR traffic. Controllers normally issue traffic information concerning other IFR aircraft, particularly in marginal weather conditions. If compliance with the restriction is not possible, the pilot should immediately advise ATC and request an amended clearance.

6.2.2 Visual Flight Rules (VFR) Release of an Instrument Flight Rules (IFR) Aircraft

When a delay is experienced in receiving an IFR departure clearance, a pilot may request approval to depart and maintain VFR until an IFR clearance can be received. The conditions in the subsection above also apply in this situation. If the request for a VFR departure is approved, the pilot will be given a time, altitude or location at which to contact ATC for an IFR clearance. Depending upon the reasons for the IFR departure clearance delay, a VFR departure of an IFR flight may not be approved by the IFR unit. In situations such as these, it may be desirable for the pilot to wait for the IFR departure clearance.

6.3 Emergencies and Equipment Failures — Instrument Flight Rules (IFR)

6.3.1 Declaration of Emergency

Whenever pilots are faced with an emergency situation, ATC expects the pilot to take whatever action is considered necessary. ATC will assist pilots in any way possible whenever an emergency is declared. Pilots are requested to advise ATC of any deviations from IFR altitudes or routes necessitated by an emergency situation as soon as it is practicable in order that every effort can be made to minimize conflicts with other aircraft.

Pilots of transponder-equipped aircraft, when experiencing an emergency and unable to establish communications immediately with an ATC unit, may indicate “Emergency” to ATC by adjusting the transponder to reply to Mode A/3 Code 7700. Thereafter, radio communications should be established with ATC as soon as possible.

It should be pointed out, however, that when Code 7700 is used, the signal may not be detected because the aircraft may not be within the range of SSR coverage.

6.3.2 Two-Way Communications Failure

It is impossible to provide regulations and procedures applicable to all possible situations associated with a two-way communications failure. During a communications failure, when confronted by a situation not covered in the regulations, pilots are expected to exercise good judgment in whatever action they elect to take. The following procedures are the standard communications failure procedures; however, they may be superseded by specific procedures that take precedence. For example, some missed approach and SID procedures may have specific published communications failure procedures.

6.3.2.1 General

Unless otherwise authorized by ATC, the pilot-in-command of an aircraft that experiences a two-way communications failure when operating in or cleared to enter controlled airspace under IFR, or when operating in or cleared to enter Class B or C airspace under VFR shall:

- (a) select the transponder to reply to Mode A/3 Code 7600 interrogations, if the aircraft is transponder-equipped;

- (b) maintain a listening watch on appropriate frequencies for control messages or further clearances; acknowledge receipt of any such messages by any means available, including the use of approved satellite voice equipment or the selective use of the normal/standby functions of transponders;
- (c) attempt to contact any ATC facility or another aircraft, inform them of the difficulty, and request they relay the information to the ATC facility with whom communications are intended;
- (d) comply with the procedures specified by the Minister in the CAP and the CFS, except where specific instructions to cover an anticipated communications failure have been received from an ATC unit; and
- (e) attempt to contact the appropriate NAV CANADA ATS unit by means of a conventional cell or satellite phone, when all of the above attempts have failed.

NOTE:

Approved SATCOM voice equipment refers to on-board embedded equipment. Permanent satellite voice equipment is installed and tested in accordance with appropriate certification and airworthiness standards.

6.3.2.2 Instrument Flight Rules (IFR) Flight Plan

Visual Meteorological Conditions (VMC): If the failure occurs in VMC, or if VMC are encountered after the failure, the pilot-in-command shall continue the flight under VFR and land as soon as practicable.

NOTE:

This procedure applies in any class of airspace. The primary purpose is to preclude extended IFR operation in controlled airspace in VMC. However, it is not intended that the requirement to “land as soon as practicable” be construed to mean “land as soon as possible.” The pilot retains the prerogative of exercising his/her best judgment and is not required to land at an unauthorized airport, at an airport unsuitable for the type of aircraft flown, or to land only minutes short of destination.

Instrument Meteorological Conditions (IMC): If the failure occurs in IMC, or if the flight cannot be continued under VMC, the pilot-in-command shall continue the flight according to the following:

- (a) **Route**
 - (i) by the route assigned in the last ATC clearance received and acknowledged;
 - (ii) if being vectored, by the direct route from the point of communications failure to the fix, route, or airway specified in the vector clearance;
 - (iii) in the absence of an assigned route, by the route that ATC has advised may be expected in a further clearance; or
 - (iv) in the absence of an assigned route or route that ATC has advised may be expected in a further clearance, by the route filed in the flight plan.

- (b) **Altitude:** At the highest of the following altitudes or FLs for the route segment being flown:
 - (i) the altitude(s) or FLs assigned in the last ATC clearance received and acknowledged;
 - (ii) the minimum IFR altitude; or
 - (iii) the altitude or FL ATC has advised may be expected in a further clearance. (The pilot shall commence climb to this altitude/FL at the time or point specified by ATC to expect further clearance/ altitude change.)

NOTES:

1. The intent of this is that an aircraft that has experienced a communications failure will, during any segment of a flight, be flown at an altitude that provides the required obstacle clearance.
 2. If the failure occurs while being vectored at a vectoring altitude that is lower than a published IFR altitude, the pilot shall immediately climb to and maintain the appropriate minimum IFR altitude until arrival at the fix, route or airway specified in the clearance.
- (c) **Descent for Approach:** Maintain en route altitude to the navigation facility or the approach fix to be used for the IAP selected and commence an appropriate descent procedure at whichever of the following times is the most recent:
 - (i) the ETA (ETA as calculated from take-off time plus the estimated time en route filed or amended [with ATC]);
 - (ii) the ETA last notified to and acknowledged by ATC; or
 - (iii) the EAT last received and acknowledged.

If failure occurs after you have received and acknowledged a holding instruction, hold as directed and commence an instrument approach at the EAT or expected further clearance time (EFC), whichever has been issued.

NOTES:

1. If the holding fix is not a fix from which an approach begins, leave the fix at the expected further clearance time if one has been received. If none has been received, proceed to a fix from which an approach begins upon arrival over the clearance limit. Commence descent and/or approach as close as possible to the ETA as calculated from the filed estimated time en route or as amended with ATC.
2. If cleared for a STAR, maintain the appropriate altitude described above and proceed to the final approach fix (FAF):
 - (a) via the published routing;
 - (b) via the published routing to the segment where vectors are depicted to commence, then direct to the facility or fix serving the runway advised by ATIS or specified in the ATC clearance, for a straight-in approach, if able, or for the full procedure if one is published;
 - (c) for a CLOSED RNAV STAR, by flying the arrival as published, including any vertical and speed restraints

depicted in the procedure, and intercepting the final approach course for a straight-in approach; or

- (d) for an OPEN RNAV STAR, by flying the arrival as published, including any vertical and speed restraints depicted in the procedure. The pilot is expected to delete the heading leg at the DTW, to initiate an auto-turn at the DTW and FAF and to intercept the final approach course for a straight-in approach.

For flights to the United States, communications failure procedures are essentially the same, but it is the pilot's responsibility to consult the appropriate American publications. Some instrument procedures do not include a procedure turn but include the statement "ATS SURVEILLANCE REQUIRED" as part of the procedure. The initial approach segment of these instrument procedures is being provided by ATC vectors. Without ATC vectoring, the instrument procedure may not have a published initial approach segment.

Should an aircraft communications failure occur while the aircraft is being vectored on one of these approaches, separately or as part of a STAR, the pilot is expected to comply with the communications failure procedure by selecting the transponder to Mode A/3 Code 7600 immediately. Pilots should always be aware of the traffic situation. For example, ATC may have indicated that your aircraft was second for an approach to Runway 06L; under these circumstances, the flight should be continued along the route that normally would have been expected under vectoring. In some cases of communications failure, pilots may need to revert to dead reckoning navigation (DR) to the final approach course. It is important to other aircraft and ATC for the aircraft experiencing a communications failure to continue the flight along a route that would permit the aircraft to conduct a straight-in approach and landing without unexpected manoeuvring. Pilots are expected to exercise good judgment in these cases. Unexpected manoeuvres, such as turns away from the final approach course, may cause traffic disruptions and conflicts.

If the communications failure occurs while being vectored at a vectoring altitude that is lower than a published IFR altitude (e.g. minimum sector altitude 25 NM), the pilot shall immediately climb to and maintain the appropriate minimum IFR altitude until arrival at a fix associated with the instrument procedure.

Modern technology has introduced new on-board communications capabilities, such as airborne telephone communications. Pilots who are confronted with an aircraft communications failure may, if circumstances permit, use this new on-board technology to establish communications with the appropriate ATC units. NAV CANADA publishes the phone numbers of ACCs, control towers, FICs and FSSs in the CFS.

6.3.3 Reporting Malfunctions of Navigation and Communications Equipment

The pilot-in-command of an aircraft in IFR flight within controlled airspace should report immediately to the appropriate ATC unit any malfunction of navigation or air-ground communications equipment.

Examples:

- Loss of VOR, ADF or low frequency navigation capability.
- Complete or partial loss of ILS capability.
- Impairment of air-ground communications capability.
- Impairment of transponder serviceability.

Having received this information, ATC will take into account any limitations in navigation or air-ground communications equipment in further clearances to the aircraft.

6.3.4 Fuel Dumping

Whenever it is necessary to jettison fuel, the pilot should immediately notify ATC and provide information such as the course to be flown, the period of time and weather conditions. To allow for adequate vaporization, fuel dumping should be carried out at least 2 000 feet above the highest obstacle within 5 NM of the track to be flown. ATC may suggest an alternate area where fuel should be dumped; aircraft will be encouraged to dump fuel on a constant heading over unpopulated areas and clear of heavy traffic. When necessary information has been obtained, ATC will broadcast on appropriate frequencies a “fuel dumping” advisory. Pilots should advise ATC immediately when fuel dumping has been completed.

6.4 Instrument Flight Rules (IFR) Separation

6.4.1 General

The following information is intended to acquaint pilots with some of the basic non-ATS surveillance separation standards applied by ATC and so facilitate flight planning and understanding of ATC techniques.

6.4.2 Vertical Separation — General

The standard vertical separation minima is as follows:

- FL 290 and below – 1 000 ft;
- above FL 290 – 2 000 ft.

6.4.3 Vertical Separation Between Flight Levels and Altitudes Above Sea Level (ASL)

When the altimeter setting is less than 29.92 in. Hg, there will be less than 1 000 ft vertical separation between an aircraft flying at 17 000 ft ASL with that altimeter setting and an aircraft flying at FL 180, (with altimeter set at 29.92 in. Hg); therefore, the lowest usable flight level will be assigned or approved in accordance with the following table:

Altimeter Setting	Lowest Usable Flight Level
29.92 in. or higher	FL 180
29.91 in. to 28.92 in.	FL 190
28.91 in. to 27.92 in.	FL 200

6.4.4 Longitudinal Separation—Distance-Based

Longitudinal separation of IFR flights based on distance is established by ATC on the basis of position reports, expressed in units of distance, from the concerned aircraft determined in relation to a common point. To account for the effect of slant range, controllers must know when distance reports are derived from DME when establishing longitudinal separation between a mix of RNAV/GNSS- and DME-equipped aircraft.

To this end, pilots should report distances based on RNAV and GNSS in miles, e.g. 30 mi. from “Someplace.” When distance reports are based on DME, pilots should state DME, e.g. 30 DME from “Someplace.”

NOTE:

RNAV position reports derived from DME-DME computations are not affected by slant range.

6.4.5 Lateral Separation — General

Lateral separation of IFR flights is provided by ATC in the form of “airspace to be protected” in relation to a holding procedure, instrument approach procedure or the approved track. The dimensions of protected airspace for a particular track take into account the accuracy of navigation that can be reasonably expected. For track segments within signal coverage of NDB, VOR or TACAN stations and along bearings/courses/radials of such facilities, protected airspace takes into account the accuracy of available track guidance, accuracy of airborne receiver and indicator equipment, and a small pilotage tolerance. Separation is considered to exist provided the airspaces protected for each aircraft do not overlap. It is essential, therefore, that accuracy capability of navigation equipment be maintained.

Pilots of IFR or controlled VFR flights must adhere as closely as practicable to the centreline of their approved airway or track. If the aircraft inadvertently deviates from the approved track, immediate action must be taken to regain the centreline as soon as practicable. Pilots realizing that they are outside the airspace protected for their approved track must notify the appropriate ATC unit immediately.

6.4.6 Lateral Separation — Airways and Tracks

In the low-level airspace, the airspace to be protected is the full width of the airway as illustrated in RAC Low-Level Airways.

In the high-level airspace, all airspace is controlled within the Southern, Northern, and Arctic Control Areas. As a result, a high-level airway is “a prescribed track between specified radio aids to navigation” and, thus, has no defined lateral dimensions. Therefore, the airspace to be protected for airways and/or tracks in the high-level airspace is the same as that for low-level airways.

Along off-airway tracks the “airspace to be protected” is 45 NM each side of that portion of the track which is beyond navigational and signal coverage range.

Figure 6.1—Airspace to be Protected Along Off-Airway Tracks

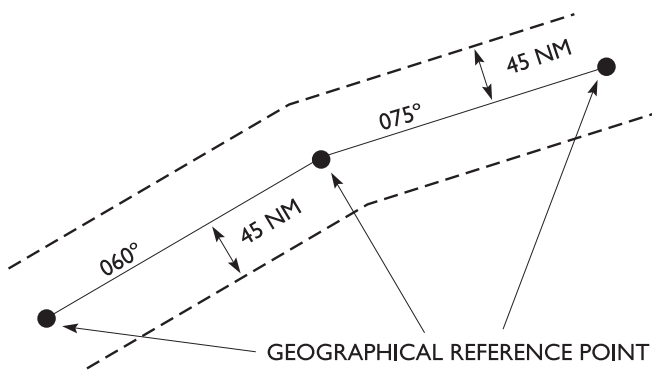

Additional airspace will be protected at and above FL 180 on the manoeuvring side of tracks that change direction by more than 15° overhead navigation aids or intersections. It is expected that pilots of aircraft operating below FL 180 will make turns so as to remain within the normal width of airways or airspace protected for off-airway tracks.

Figure 6.2—Additional Airspace to be Protected for Turns

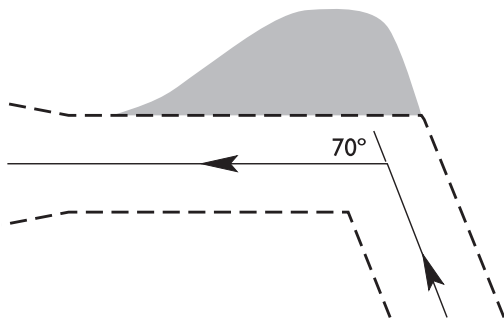

Normally, the airspace to be protected for an approved track will be based on the premise that the changeover from one navigation reference to another will take place approximately midway between facilities. Where this is not possible due to a difference in the signal coverage provided by two adjacent navigation aids, the equal signal point on an airway segment will be shown.

To remain clear of restricted areas, active danger or alert areas, or active areas such as the Churchill Rocket Range, pilots should file a flight plan so that the airspace-to-be-protected for the intended track do not overlap the area of concern.

6.4.7 Lateral Separation — Instrument Approach Procedure

Air traffic controllers have been authorized to consider the basic horizontal dimensions of intermediate approach areas, final approach areas and missed approach areas, for obstacle clearance purposes, as the airspace-to-be-protected for aircraft conducting standard instrument approach procedures. Adequate horizontal separation is then deemed to exist when the airspace-to-be-protected for such aircraft do not overlap the airspace-to-be-protected for aircraft en route, holding or

conducting simultaneous adjacent instrument approaches. As with other separation standards based on the airspace-to-be-protected concept, it will be the pilot’s responsibility to remain within the limits of airspace-to-be-protected. This can be accomplished by following the procedures published in CAP or approved for company use. If a pilot who is operating in controlled airspace anticipates being unable to conduct the approach as published, the pilot should inform ATC so that separation from other aircraft concerned can be increased as necessary.

6.5 Visual Separation

6.5.1 General

Visual separation is a means of separating IFR aircraft using visual observation and is performed by an airport controller or by a pilot, when a pilot is assigned responsibility for separation. Visual separation may be applied in a CZ or TCA at 12 500 ft ASL and below.

6.5.2 Speed Control Instructions on Departure

Visual departure separation procedures require airport controllers to consider aircraft performance, wake turbulence, closure rate, routes of flight and known weather conditions. Airport controllers do not issue speed control instructions coincident with takeoff clearances. In addition, there is no increase in the incidence of speed control instructions issued by the departure controller.

6.5.3 Controller-Applied Visual Separation

The airport controller ensures separation through visual observation of the aircraft involved. This type of visual separation cannot be applied if departure routes or aircraft performance preclude maintaining separation. ATC does not use visual separation between successive departing IFR aircraft if wake turbulence separation is required. Controller-applied visual separation is normally seamless to pilots.

6.5.4 Pilot-Applied Visual Separation

Pilot-applied visual departure separation procedures require a pilot to see the other aircraft involved and, upon instructions from the controller, maintain visual separation from the other aircraft.

Pilots who accept responsibility for visual separation must maintain constant visual contact, without referring to an airborne surveillance system, with the other aircraft involved until visual separation is discontinued. This responsibility does not eliminate the pilot’s regulatory responsibility to see and avoid other aircraft; meet noise abatement requirements; or meet obstacle clearance requirements and is not intended to restrict pilots from completing other necessary tasks.

ATC does not use pilot-applied visual separation between successive departing IFR aircraft if wake turbulence separation is required. If, for any reason, the pilot refuses pilot-applied visual separation, ATC will separate departures using another form of IFR separation.

RAC

Example phraseology for pilot-applied visual departure separation:

Tower: AIRLINE ONE TWO THREE, TRAFFIC [position, type of aircraft, intentions, etc.] CONFIRM TRAFFIC IN SIGHT?

Pilot: AIRLINE ONE TWO THREE, TRAFFIC IN SIGHT.

Tower: AIRLINE ONE TWO THREE, MAINTAIN VISUAL SEPARATION [other information or instructions, as required] CLEARED FOR TAKE-OFF.

Pilot: AIRLINE ONE TWO THREE, MAINTAINING VISUAL SEPARATION [read back additional instructions, as appropriate].

Visual separation is discontinued when either aircraft is observed on a diverging heading, unless otherwise advised by ATC.

Pilots must notify ATC as soon as possible if:

- (a) they anticipate losing sight of the other aircraft;
- (b) course deviations are required to maintain visual separation with preceding traffic; or
- (c) they suspect they will be unable to maintain visual separation for any reason.

In these cases, another form of IFR separation will be applied by ATC.

6.6 Development of Instrument Procedures

Instrument procedure development worldwide follows one of two existing standards: *ICAO Procedures for Air Navigation Services—Aircraft Operations, Volume II—Construction of Visual and Instrument Flight Procedures* (Doc 8168); or the *United States Standard for Terminal Instrument Procedures* (TERPS). Instrument procedures in CDA are developed in accordance with a document entitled *Criteria for the Development of Instrument Procedures* (TP 308). This document is a joint TC/DND publication and prescribes standardized methods for use in designing both civil and military instrument flight procedures.

In order to achieve ICAO regional commonality, the instrument procedure design standards and criteria contained in TP 308 are modeled after the standards and criteria contained in the TERPS.

Strict adherence by pilots to the published instrument procedures will ensure an acceptable level of safety in flight operations.

7.0 Instrument Flight Rules – Departure Procedures

7.1 Aerodrome Operations

Pilots should read the subsections above, in conjunction with the IFR departure procedures listed in this section.

7.2 Automatic Terminal Information Service (ATIS) Broadcasts

If available, the basic aerodrome information should be obtained from ATIS prior to requesting taxi clearance.

7.3 Initial Contact

On initial contact with ATC (clearance delivery or ground control), a pilot departing IFR should state the destination and planned initial cruising altitude.

7.4 Instrument Flight Rules (IFR) Clearances

At locations where a “Clearance Delivery” frequency is listed, pilots should obtain their IFR clearance on this frequency prior to contacting ground control. Where no clearance delivery frequency is listed, the IFR clearance will normally be relayed by ground control after taxi authorization has been issued. However, due to high fuel consumption during ground running time, some pilots of turbojet aircraft may wish to obtain their IFR clearance prior to starting engines. Pilots using this procedure should call ATC, using a phrase such as READY TO START NOW or READY TO START AT (TIME). Normally this request should be made within 5 minutes of the planned engine start time.

7.5 PRE-TAXI CLEARANCE (PTC) PROCEDURES AT STAFFED FLIGHT SERVICE STATION (FSS) SITES

At published FSS across Canada, pilots can receive pre-taxi instrument flight rules (IFR) clearance (PTC) information well ahead of their proposed departure time, which allows them to enter this information into their flight management system (FMS). Reports indicate aviation safety is increased when pilots are allowed to exercise “heads up” operations during taxi operations instead of their being preoccupied entering information in their FMS. Pre-taxi clearances are not available for IFR itineraries as they cannot be electronically formatted for pre-taxi clearance delivery.

Pre-taxi clearances relayed to pilots will contain the following restriction:

“DO NOT DEPART UNTIL DEPARTURE VALIDATION IS RECEIVED”

When the pilot is ready to taxi for departure, they will request validation from the flight service specialist who will advise the responsible controller. The controller will provide PTC validation or an amended IFR clearance to the flight service specialist who will relay this information to the pilot. Pilots must ensure they have received IFR clearance validation prior to take off. If pilots request a visual flight rule (VFR) departure after receiving a PTC, the area control center (ACC) can authorize a VFR departure on the current clearance or cancel the PTC and issue the VFR departure and a new clearance.

7.6 Standard Instrument Departure (SID)

At certain airports, an instrument flight rules (IFR) departure clearance may include departure instructions known as a standard instrument departure (SID). A SID is a planned IFR air traffic control (ATC) departure procedure, published in the *Canada Air Pilot (CAP)*, for pilot and controller use in graphic and textual form. SIDs provide a transition from the terminal to the appropriate en route structure, and may be either:

- (a) *pilot navigation SIDs*—established where the pilot is required to use the chart as reference for navigation to the en route phase; or
- (b) *vector SIDs*—established where ATC will provide navigational guidance to a filed/assigned route or to a fix depicted on the chart. Pilots are expected to use the SID chart as reference for navigation until vectoring has commenced.

SIDs incorporate obstacle and terrain clearance within the procedure. Pilots should note, however, that SIDs for military aerodromes that are only available in textual form do not incorporate obstacle and terrain clearance. At these aerodromes, it is the pilot's responsibility to ensure appropriate obstacle and terrain clearance on departure.

Pilots of aircraft operating at airports for which SIDs have been published will normally be issued a SID clearance by ATC. No pilot is required to accept a SID clearance. If any doubt exists as to the meaning of such a clearance, the pilot should request a detailed clearance.

Routings contained in SIDs will normally be composed of two segments:

- (a) an initial segment from the departure end of the runway to the position where the aircraft will first turn from the initial departure heading; and
- (b) a second segment, either via vectors or by pilot navigation, from the first turning point to the SID termination point.

When instructed to fly on the runway heading, or when flying a SID for which no specific heading is published, pilots are expected to fly or maintain the heading that corresponds with the extended centreline of the departure runway until otherwise instructed by ATC. Drift correction must not be applied, e.g. Runway 04, if the actual magnetic heading of the runway centreline is 044°, then fly a heading of 044°M.

When flying a SID for which a specific heading is published, the pilot is expected to steer the published SID heading until vectoring commences. This is because initial separation is based on divergence between assigned headings until ATS surveillance separation is established.

When assigning SIDs, ATC will include the following:

- (a) the name of SID;
- (b) the SID termination fix, if appropriate;
- (c) the transition, if necessary; and
- (d) the time or location for the aircraft to expect a climb to an operationally suitable altitude or flight level, if necessary. (**NOTE:** An “expect further clearance” statement may be included in the SID chart.)

Example:

**CLEARED TO THE CALGARY AIRPORT,
TORONTO ONE DEPARTURE, FLIGHT PLANNED
ROUTE.**

NOTE:

A SID termination fix may be a NAVAID, intersection, or DME and is normally located on an established airway where the SID terminates and the en route phase of flight commences. The SID, as published, contains an altitude to climb to after departure; however, ATC may assign an altitude different from the altitude specified in the SID, provided the altitude is stated and a readback is obtained from the pilot prior to departure. In addition, where vector SIDs are used, ATC may assign a different initial departure heading. However, an ATC revision to any item of a SID does not cancel the SID.

Example:

**CLEARED TO THE CALGARY AIRPORT,
TORONTO ONE DEPARTURE, FLIGHT PLANNED
ROUTE, CLIMB TO AMENDED ALTITUDE, SEVEN
THOUSAND...**

If an aircraft is issued a vector SID, vectors will be used, as traffic permits, to provide navigational guidance to the filed/assigned route and over the SID termination fix. However, if the controller or the aircraft will gain an operational advantage, the aircraft may be vectored on a route that will not take the aircraft over the SID termination fix.

In this case, if ATC had previously specified a SID termination fix as the location for the aircraft to expect to climb to an operationally suitable altitude or flight level, the controller shall cancel the SID. If, with the change of clearance, it is not practicable for the controller to assign an operationally suitable altitude or flight level, the controller will specify another location or time to expect the higher altitude.

Example:

**SID CANCELLED, VECTORS TO (fix or airway)
(heading). EXPECT FLIGHT LEVEL THREE FIVE
ZERO AT FOUR FIVE D-M-E WEST OF
EDMONTON VORTAC.**

It is impossible to precisely define “operationally suitable altitudes” to meet requirements in all circumstances.

The following are considered operationally suitable altitudes or flight levels:

- (a) *piston aircraft*—flight planned altitude or lower; and

- (b) *other aircraft*—flight planned altitude or altitude as near as possible to the flight planned altitude, taking into consideration the aircraft’s route of flight. As a guideline, an altitude not more than 4 000 ft below the flight planned flight level in the high-level structure will be considered as operationally suitable in most cases.

If it is not practicable for the controller to assign the flight planned altitude and if the pilot has not been informed as to when they may expect a clearance to another altitude, it is the pilot’s responsibility to advise ATC if the currently assigned altitude is not satisfactory to permit the aircraft to proceed to the destination airport, should a communications failure occur.

The controller will then be required to issue an appropriate “expect further clearance” statement or issue alternative instructions.

Controllers are required to issue a clearance to the altitude or flight level the pilot was told to expect prior to the time or location specified in an “expect further clearance” statement. The pilot must ensure that further clearance is received because the “altitude to be expected” included in the clearance is not applicable:

- (a) once the aircraft has proceeded beyond the fix specified in the “expect further clearance” statement; or
- (b) once the time designated in the “expect further clearance” statement has expired.

SIDs may include specific communications failure procedures. These specific procedures supersede the standard communication failure procedures.

SIDs, as published, will not contravene noise abatement procedures. ATC-assigned vectors will not normally contravene noise abatement procedures; however, for flight safety reasons, ATC may be required to issue a vector contrary to noise abatement requirements.

ATC-assigned vectors shall be followed in a timely manner even if they conflict with the published noise abatement procedures.

The initial call to departure control should contain at least:

- (a) the aircraft call sign;
- (b) the departure runway;
- (c) the present vacating altitude (to the nearest 100-ft increment); and
- (d) the assigned (SID) altitude.

Example:

*OTTAWA DEPARTURE, BEECH GOLF ALFA
BRAVO TANGO, OFF RUNWAY 25, HEADING 250,
LEAVING 1 900 FOR 4 000.*

NOTE:

An altitude readout is valid if the readout value does not differ from the aircraft reported altitude by more than 200 ft. Pilot altitude reports should be made to the nearest 100-ft increment.

7.7 Noise Abatement Procedures — Departure

7.7.1 General

These aeroplane operating procedures for the takeoff and climb have been developed so as to ensure that the necessary safety of flight operations is maintained whilst minimizing exposure to noise on the ground. One of the two procedures listed in the subsections below should be applied routinely for all takeoffs where noise abatement procedures are in effect.

Nothing in these procedures shall prevent the pilot-in-command from exercising authority for the safe operation of the aeroplane, except that when a climb gradient is published, it must be maintained, or alternate procedures must be adopted.

The procedures herein describe the methods for noise abatement when a noise problem is evident. They can comprise any one or more of the following:

- (a) use of noise preferential runways to direct the initial and final flight paths of aeroplanes away from noise-sensitive areas;
- (b) use of noise preferential routes to assist aeroplanes in avoiding noise-sensitive areas on departure and arrival, including the use of turns to direct aeroplanes away from noise-sensitive areas located under or adjacent to the usual takeoff and approach flight paths; and
- (c) use of noise abatement takeoff or approach procedures, designed to minimize the overall exposure to noise on the ground and, at the same time, maintain the required levels of flight safety.

7.7.2 Noise Preferential Runways

Preferred runway directions for takeoff are designated for noise abatement purposes; the objective being to use, whenever possible, those runways that permit aeroplanes to avoid noise-sensitive areas during the initial departure and final approach phases of flight.

Noise abatement is not the determining factor in runway designation under the following circumstances:

- (a) if the runway is not clear and dry, i.e. it is adversely affected by snow, slush, ice, water, mud, rubber, oil or other substances;
- (b) when the crosswind component, including gusts, exceeds 25 KIAS; and
- (c) when the tail wind component, including gusts, exceeds 5 kt.

NOTE:

Although ATS personnel may select a preferential runway in accordance with the foregoing criteria, pilots are not obligated to accept the runway for taking off or landing. It remains the pilot’s responsibility to decide if the assigned runway is operationally acceptable.

7.7.3 Noise Abatement Departure Procedure (NADP)

NADPs are designed to minimize the environmental impact of departing aircraft without compromising safety. Typically, operators require two procedures: one to minimize close-in noise (NADP 1) and the other to minimize noise over a more distant noise-sensitive area (NADP 2).

Under the NADP concept, airport operators identify their noise and emission control needs and may identify specific noise-sensitive areas. Aircraft operators choose the departure method that safely meets the airport operator's objectives.

When deciding on a noise abatement strategy, it is important to keep in mind that each procedure minimizes noise in its target area at the expense of relatively increased noise elsewhere. NADP 1 reduces noise immediately after takeoff but results in higher downrange noise than NADP 2, and vice versa. For each aircraft type, powerplant and set of take-off conditions, there is a distance at which the NADP 1 and NADP 2 noise contours cross over. The area from the take-off to the crossover point defines the close-in zone of NADP 1, while the area beyond the crossover point is the effective range of NADP 2.

When developing a noise abatement strategy, airports and air operators should consider the following:

- (a) All necessary obstacle data shall be made available to the operator, and the procedure design gradient shall be observed.
- (b) The power or thrust settings specified in the aircraft operating manual are to take account of the need for engine anti-icing when applicable.
- (c) Noise abatement procedures shall not be executed below 800 ft AAE.
- (d) The level of power or thrust for the flap/slat configuration, after power/thrust reduction, shall not be less than:
 - (i) for aeroplanes in which derated take-off thrust and climb thrust are computed by the flight management system, the computed climb power/thrust; or
 - (ii) for other aeroplanes, normal climb power/thrust.
- (e) To minimize the impact on training while maintaining flexibility to address variations in the location of noise-sensitive areas, the operator shall develop no more than two noise abatement procedures for each aeroplane type. One procedure should provide noise benefits for areas close to the aerodrome, and the other for areas more distant from the aerodrome.
- (f) Any difference of power/thrust reduction initiation height for noise abatement purposes constitutes a new procedure.
- (g) Noise abatement departure shall not invalidate an engine-out departure procedure (EODP).
- (h) Where possible, each aircraft type should base its standard departure procedure on the noise abatement strategy that minimizes its overall noise impact.
- (i) Operators serving certain noise-sensitive airports may need to follow specific, non-standard departure procedures. Crew

training and departure information shall address identification and procedural differences associated with alternate noise abatement procedures.

- (j) Where applicable, air traffic control agencies should be involved in the development of noise abatement procedures.

In addition to the above general requirements, the following operational limitations apply:

- (a) The pilot-in-command has the authority to decide not to execute a noise abatement departure procedure if conditions preclude the safe execution of the procedure.
- (b) NADPs requiring reduced take-off power/thrust settings may be flown only when reduced power/thrust is permitted by the aircraft flight manual or aircraft operating manual.
- (c) Initial power or thrust reductions shall not be executed below a height of 800 ft AAE.
- (d) Aircraft limitations, including maximum body angle limits, shall always be respected.
- (e) Noise abatement procedures are not to be used when wind shear warnings exist, or the presence of wind shear or microburst activity is suspected.
- (f) Power or thrust settings to be used after the failure or shutdown of an engine or any other apparent loss of performance, at any stage in the take-off or noise abatement climb, are at the discretion of the pilot-in-command, and noise abatement considerations no longer apply. An engine failure during takeoff is a non-normal condition, and therefore takes precedence over noise abatement, air traffic, SIDs, departure procedures, and other normal operating considerations.
- (g) Conduct of noise abatement procedures is secondary to the satisfaction of obstacle requirements.

NADPs start at or above 800 ft and initiate the final stage at or below 3 000 ft AAE, allowing operators to develop specific procedures to suit their local situations.

To illustrate the concept, two NADP-compliant procedures are described below. Each one describes one method, but not the only method, of providing noise reduction for noise-sensitive areas. Operators are free to design other procedures that fit within the NADP envelopes.

7.7.3.1 NADP 1 (Criteria for a Close-in Noise-sensitive Area) Description

This procedure involves a power reduction at or above the prescribed minimum altitude (no less than 800 ft) AAE and delaying flap/slat retraction until the prescribed maximum altitude (3 000 ft) AAE is attained. At 3 000 ft AAE, accelerate and retract flaps/slats on schedule, while maintaining a positive rate of climb, and complete the transition to normal en route climb speed. The initial climbing speed to the noise abatement initiation point is no less than $V_2 + 10$ KIAS.

In summary:

- (a) Initial climb to at least 800 ft AAE:
 - (i) power/thrust as set for takeoff;
 - (ii) flaps/slats in take-off configuration; and
 - (iii) climb speed not less than $V_2 + 10$ kt.
- (b) At or above 800 ft AAE:
 - (i) initiate power/thrust reduction;
 - (ii) maintain climb speed not less than $V_2 + 10$ kt to 20 kt; and
 - (iii) maintain flaps/slats in take-off configuration.
- (c) At 3 000 ft AAE:
 - (i) maintain positive rate of climb;
 - (ii) accelerate to en route climb speed; and
 - (iii) retract flaps/slats on schedule.

Specific example of an NADP 1 profile:

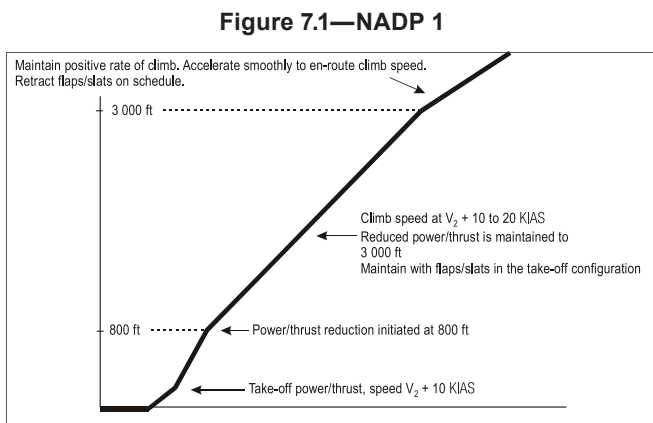

Noise abatement take-off climb — Example of a procedure alleviating noise close to the aerodrome (NADP 1)

NOTE:

To assist in planning departure spacing, pilots intending to use NADP 1 at Canadian airports are to notify ATC clearance delivery or ground control. At airports where NADP 1 is the only procedure to follow, ATC does not need to be notified.

7.7.3.2 NADP 2 (Criteria for a More Distant Noise-sensitive Area) Description

This procedure involves the initiation of flap/slat retraction and accelerating towards V_{ZF} at or above the prescribed minimum altitude (800 ft) AAE but before reaching the prescribed maximum altitude (3 000 ft) AAE. The flaps/slats are to be retracted on schedule, while maintaining a positive rate of climb. Intermediate flap retraction, if required for performance, may be accomplished below the prescribed minimum altitude. The power/thrust reduction is initiated at a point along the acceleration segment that ensures satisfactory acceleration performance. At the prescribed maximum altitude, complete the transition to normal en route climb procedures. The initial climbing speed to the noise abatement initiation point is no less than $V_2 + 10$ KIAS and the noise abatement procedure is not to be initiated at less than 800 ft AAE.

In summary:

- (a) Initial climb to at least 800 ft AAE:
 - (i) power/thrust as set for takeoff;
 - (ii) flaps/slats in take-off configuration; and
 - (iii) climb speed not less than $V_2 + 10$ kt.
 - (b) At or above 800 ft AAE, maintain a positive rate of climb and accelerate towards V_{ZF} and:
 - (i) retract flaps/slats on schedule; and
 - (ii) reduce power/thrust at a point along the acceleration segment that ensures satisfactory acceleration performance.
 - (c) Continue the climb to 3 000 ft AAE at a climb speed of not less than V_{ZF} .
 - (d) At 3 000 ft AAE, transition to normal en route climb speed.
- Specific example of an NADP 2 profile:

Figure 7.2—NADP 2

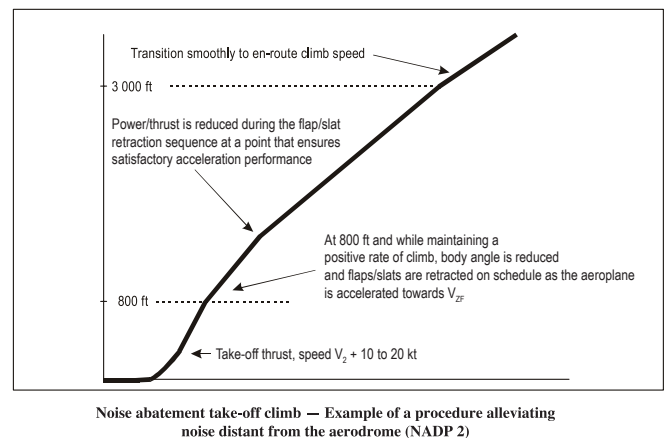

Noise abatement take-off climb — Example of a procedure alleviating noise distant from the aerodrome (NADP 2)

The use of this guidance material should be limited to acquiring general insight into NADPs. In applying this guidance, users should seek expert noise and emissions advice.

7.8 Obstacle and Terrain Clearance

Aerodromes that have an instrument approach procedure (IAP) published in the *Canada Air Pilot* (CAP) also have an instrument flight rules (IFR) departure procedure.

There are two types of IFR departure procedures: the standard instrument departure (SID) and the obstacle departure procedure (ODP). SIDs are developed to establish a traffic flow (see RAC 7.5) while ODPs are pilot initiated. Both types meet obstacle and terrain clearance requirements.

IFR departure procedures are expressed in the form of take-off minima on an aerodrome chart. These procedures are based on the premise that, on departure, an aircraft will

- (a) cross at least 35 ft above the departure end of the runway;
- (b) climb straight ahead to 400 ft above aerodrome elevation (AAE) before turning; and
- (c) maintain a climb gradient of at least 200 ft/NM throughout the climb to a minimum IFR altitude for en route operations.

Climb gradients greater than 200 ft/NM may be published. In this case, the aircraft is expected to achieve and maintain the published gradient to the specified altitude or fix, then continue climbing at a minimum of 200 ft/NM until reaching a minimum IFR altitude for en route operations.

For flight planning purposes, IFR departure procedures assume normal aircraft performance in all cases.

ODPs in the take-off minima box are shown as either:

- (a) **1/2**—This indicates that IFR departures from the specified runway(s) will be assured of obstacle and terrain clearance in any direction, if the aircraft meets the previously stated departure premise. Pilots may consider this procedure as “takeoff, climb on course.” The minimum visibility (unless otherwise approved by the appropriate authority) for takeoff in these circumstances is 1/2 SM. IFR takeoffs for rotorcraft are permitted when the take-off visibility is reduced to half the CAP value, but no less than 1/4 SM.
- (b) * (**asterisk**)—The asterisk (*) following all or specific runways refers the pilot to the applicable minimum take-off visibility (1/2 or SPEC VIS) and the corresponding procedures which, if followed, will ensure obstacle and terrain clearance. Procedures may include specific climb gradients, routings, visual climb requirements, locations of close-in obstacles (see RAC 7.7.2), or combinations thereof. Where a visual climb is stated in the departure procedure, pilots are expected to comply with the specified takeoff minimum visibility (SPEC VIS) corresponding to the appropriate aircraft category listed in the following table:

Table 7.1—Aircraft Categories and the Associated SPEC VIS

Aircraft Category	A	B	C	D
SPEC VIS in SM	1	1 1/2	2	2

NOTE

No reductions in SPEC VIS are permitted for rotorcraft. For further information on SPEC VIS, see RAC 7.7.1.

- (c) **NOT ASSESSED**—IFR departures have not been assessed for obstacles. Pilots-in-command (PICs) are responsible for determining minimum climb gradients and/or routings for obstacle and terrain avoidance.

In the absence of a published visibility for a particular runway, a pilot may depart IFR only if take-off visibility will allow avoidance of obstacles and terrain on departure. In no case should the take-off visibility be less than 1/2 SM (1/4 SM for rotorcraft).

Where aircraft limitations or other factors preclude the pilot from following the published procedure, it is the PIC’s responsibility to determine alternative procedures that take into account obstacle and terrain avoidance.

Air traffic control (ATC) terms such as “on departure, right turn climb on course” or “on departure, left turn on course” are not

to be considered specific departure instructions. It remains the pilot’s responsibility to ensure that terrain and obstacle clearance has been achieved by conforming to the IFR departure procedures.

7.8.1 Visual Climb Over The Airport (VCOA)

VCOA—sometimes referred to as “climb visual” or “visual climb” in the CAP—was developed to provide an alternate IFR departure procedure for aircraft that cannot meet the greater-than-standard climb gradient specified in the primary instrument departure procedure.

NOTE:

Occasionally, VCOA may be the only available departure procedure developed for an aerodrome.

VCOA differs from other instrument departure procedures in that the pilot must maintain certain visual references with the ground and obstacles until reaching a given altitude over the aerodrome.

NOTE:

Even though the aircraft is being operated with visual references to the ground, it is still departing on an IFR clearance.

The VCOA text includes a SPEC VIS and a climb-to altitude in feet above sea level. The SPEC VIS is the minimum visibility in statute miles that a pilot requires to manoeuvre the aircraft while climbing. The climb-to altitude is the minimum altitude above the aerodrome that the aircraft must reach before departing en route.

It is the pilot’s responsibility to see and avoid obstacles while climbing visually. The pilot should be familiar with the local terrain and the obstacles that surround the aerodrome and plan the climb appropriately. Taking local traffic and obstacles into consideration, it is advisable that the pilot keep the aerodrome in sight while climbing. The visual climb segment ends when the aircraft crosses the aerodrome at or above the required minimum altitude. From this point on, obstacles will be cleared if the aircraft maintains a minimum climb gradient of 200 ft/NM to the en-route structure.

The PIC should ensure that the reported ceiling is above the climb-to altitude and that the local prevailing visibility is equal to or greater than that required in the procedure. Additionally, before taxiing for departure, the PIC should inform ATC of the intention to perform a VCOA so that the appropriate coordination can be ensured. If ATC services are not available, then intentions should be broadcast on the ATF (see RAC 7.9).

7.8.2 Low, Close-in Obstacles

Obstacles that penetrate the standard OCS require the publication of a climb gradient. However, certain close-in obstacles may be exempt from this requirement. Instead, a note is published on the departure procedure and/or on the aerodrome chart. The note alerts the pilot to the nature of the close-in obstacle and gives its height and location so that it may be avoided. An obstacle is determined to be “close-in” if it is within 1 NM of the departure end of the runway, or within 1 NM from the end of the clearway, if a clearway exists. Either way, the charted distance to the obstacle will be noted as being from the departure end of the runway.

If the obstacle(s) cannot be visually acquired during departure, pre-flight planning should take into account the turns or other manoeuvres that may be necessary immediately after takeoff to avoid the obstacle(s). These obstacles are especially critical to aircraft that do not lift off until close to the departure end of the runway or that climb at the minimum rate.

7.9 Release from Tower Frequency

If the departure airport is located within a terminal control area, the departing IFR flight will be cleared by the tower to contact a specific control unit on a specified frequency once clear of conflicting airport traffic. At certain locations, flights will be advised prior to takeoff to change to a specified departure frequency. In this case, the change should be made as soon as practicable after takeoff.

If the departure airport is not located within a terminal control area, the pilot, when requesting release from tower frequency, should advise the tower of the agency or frequency to which he/she will change unless directions for the change were included in the ATC clearance.

7.10 Instrument Flight Rules (IFR) Departures from Uncontrolled Airports

Where a pilot-in-command intends to take off from an uncontrolled aerodrome, the pilot shall:

- obtain an ATC clearance if in controlled airspace;
- report their departure procedure and intentions on the appropriate frequency before moving on to the runway or before aligning the aircraft on the take off path; and
- ascertain by radio on the appropriate frequency and by visual observation that no other aircraft or vehicle is likely to come into conflict with the aircraft during takeoff.

The pilot-in-command shall maintain a listening watch:

- during takeoff from an uncontrolled aerodrome; and
- after takeoff from an uncontrolled aerodrome for which a MF has been designated, until the aircraft is beyond the distance or above the altitude associated with that frequency.

As soon as possible after reaching the distance or altitude associated with the MF, the pilot-in-command shall communicate with the appropriate ATC unit or a ground station on the appropriate en-route frequency.

Where IFR departures are required to contact an IFR control unit or ground station after takeoff, it is recommended that, if the aircraft is equipped with two radios, the pilot should also monitor the MF during the departure.

If the aerodrome is located in uncontrolled airspace, these procedures shall be followed except that an ATC clearance is not required. In addition to maintaining a listening watch, it is recommended that the pilot-in-command communicate with the appropriate ATC unit, FIC, or other ground station on the appropriate en-route frequency.

NOTE:

It is recommended that pilots inform ATC if a flight will not commence within 60 min of the proposed departure time stipulated in an IFR flight plan. Failure to do so will result in activating the SAR process.

At an uncontrolled aerodrome, the initial IFR clearance may contain a time or an event-based departure restriction or clearance cancellation.

Examples:

ATC CLEARS AIRLINE123 (IFR clearance) DO NOT DEPART UNTIL 1340; CLEARANCE CANCELLED IF NOT AIRBORNE BEFORE 1349.

or

ATC CLEARS AIRLINE123 (IFR clearance) DO NOT DEPART UNTIL CESSNA ABC HAS LANDED; CLEARANCE CANCELLED IF NOT AIRBORNE BEFORE 1349.

In the first example, the clearance is valid the moment the time turns 1340, and in both examples, the clearance is cancelled the moment the time turns 1349.

7.11 Alerting Service Instrument Flight Rules (IFR) Departures from Uncontrolled Airports

At locations where communication with ATS is difficult, pilots may elect to depart VFR and obtain their IFR clearance once airborne. In Canada, if IFR clearance is not received prior to departure, SAR alerting service is activated based on the ETD filed in the flight plan. However, if departing from a Canadian airport that underlies airspace delegated to FAA control, then responsibility for SAR alerting service is transferred to the FAA and FAA procedures apply. In such cases, alerting service is not activated until the aircraft contacts ATS for IFR clearance. Therefore, if the aircraft departs before obtaining its IFR clearance, alerting service is not provided until contact is established with ATS.

8.0 Instrument Flight Rules (IFR) – En Route Procedures

8.1 Position Reports

Pilots of instrument flight rules (IFR) and controlled VFR (CVFR) flights are required to make position reports over compulsory reporting points specified on IFR charts, and over any other reporting points specified by air traffic control (ATC).

As specified in *Canadian Aviation Regulation* (CAR) 602.125, the position report shall include the information in the sequence set out on page C2 of the *Canada Flight Supplement* (CFS), that is:

- (a) the identification;
- (b) the position;
- (c) the time over the reporting point in coordinated universal time (UTC);
- (d) the altitude or flight level;
- (e) the type of flight plan or flight itinerary filed;
- (f) the name of the next designated reporting point and estimated time of arrival (ETA) over that point in UTC;
- (g) the name only of the next reporting point along the route of flight (see NOTE); and
- (h) any additional information requested by ATC or deemed necessary by the pilot.

NOTE:

Reporting points are indicated by a symbol on the appropriate charts. The “designated compulsory” reporting point is a solid triangle and the “on request” reporting point symbol is an open triangle. Position reports over an “on request” reporting point are only necessary when requested by ATC. Therefore, no mention of an “on request” reporting point needs to be made in any position report unless it has been requested by ATC.

En route IFR and CVFR flights should establish direct controller-pilot communications (DCPC) wherever possible. Peripheral stations (PAL) have been established at a number of locations to extend the communications coverage. Some PAL locations also employ a radio re-transmit unit (RRTU). The purpose of the RRTU is to transmit a pilot’s broadcast from one PAL location over another frequency at a different PAL location. This allows the pilot to know when the controller is working communications traffic on a different PAL frequency. Controllers at an area control centre (ACC) can disable this equipment when necessary due to the communications workload. However, it must be remembered that, while DCPC provides direct contact with the IFR unit at locations where there is no VFR control and aerodrome advisory service (AAS) or remote aerodrome advisory service (RAAS) is provided, pilots must also communicate with the flight service station (FSS) or flight information centre (FIC) for local traffic information. Whenever DCPC cannot be established, or whenever ATC has instructed a pilot to contact a FIC, position reports shall be made through the assigned FIC or the nearest communications agency en route.

When the pilot-in-command of an IFR aircraft is informed that the aircraft has been IDENTIFIED, position reports over compulsory reporting points are no longer required. Pilots will be informed when to resume normal position reporting.

In order that flight information and alerting service may be provided to all IFR flights outside controlled airspace, pilots should make position reports over all navigation aids (NAVAID) along the route of flight to the nearest station with air-ground communications capability.

If the time estimate for the next applicable reporting point differs from the previously reported estimate by 3 min or more, a revised estimated time should be reported to the appropriate air traffic service (ATS) unit as soon as possible.

8.2 Mach Number/True Airspeed—Clearances and Reports

8.2.1 Mach Number

Clearances to turbojet aircraft equipped with a Machmeter may include an appropriate Mach number. If the Mach number cannot be adhered to, ATC is to be so informed when the clearance is issued. Once accepted, the Mach number shall be adhered to within .01 Mach, unless ATC approval is obtained to make a change. If an immediate temporary change in Mach number is necessary (e.g. because of turbulence), ATC must be notified as soon as possible. When a Mach number is included in a clearance, the flight concerned should transmit its current Mach number with each position report.

8.2.2 True Airspeed (TAS)

ATC is to be notified as soon as practicable of an intended change to the TAS at the cruising altitude or flight level, where the change intended is five percent or more of the TAS specified in the IFR flight plan or flight itinerary.

8.3 Altitude Reports

Although the CARs do not specifically direct pilots to report altitude information to ATC, pilots, if not operating in ATS surveillance airspace (i.e. identified by ATC), should report reaching the altitude to which the flight has been initially cleared. When climbing or descending en route, pilots should report when leaving a previously-assigned altitude and when reaching the assigned altitude.

On initial contact with ATC, or when changing from one ATC frequency to another, when operating in surveillance or non-surveillance airspace, pilots of IFR and CVFR flights should state the assigned cruising altitude and, when applicable, the altitude through which the aircraft is climbing or descending.

In order for ATC to use Mode C altitude information for separation purposes, the aircraft Mode C altitude readout must be verified. The Mode C altitude is considered valid if the readout value does not differ from the aircraft reported altitude by more than 200 ft. The readout is considered invalid if the difference is 300 ft or more. Therefore, it is expected that pilot altitude reports, especially during climbs and descents, will be made to the nearest 100-ft increment.

Example:

EDMONTON CENTRE, AIR CANADA EIGHT ZERO ONE HEAVY, LEAVING EIGHT THOUSAND THREE HUNDRED FEET, CLIMBING TO FLIGHT LEVEL THREE FIVE ZERO.

If the phrase “report reaching”, “report leaving” or “report passing” is used by ATC, the pilot shall comply (CAR 602.31—*Compliance with Air Traffic Control Instructions and Clearances*).

8.4 Climb or Descent

8.4.1 General

During any phase of flight, pilots should adhere to the following procedures:

- (a) When an altitude clearance is issued, the pilot should begin the climb or descent promptly on acknowledgement of the clearance. The climb or descent should be made at an optimum rate consistent with the operating characteristics of the aircraft. If the above is not the case, or if it becomes necessary to stop the climb or descent, the pilot should advise ATC of the interruption or the delay in vacating an altitude.
- (b) If the phrase “when ready” is used in conjunction with an altitude clearance or instruction, the change of altitude may be initiated whenever the pilot wishes. The climb or descent should be made at an optimum rate consistent with the operating characteristics of the aircraft. When not informed that the aircraft has been IDENTIFIED, pilots are expected to advise ATC when the altitude change is initiated. Compliance with assigned or published altitude crossing restrictions and speeds is mandatory (CAR 602.31), unless specifically cancelled by ATC. (MEAs are not considered restrictions; however, pilots are expected to remain at or above MEAs.)

NOTE:

When an aircraft reports vacating an altitude, ATC may assign the altitude to another aircraft. Control will be based on the pilot following these procedures and on the normal operating characteristics of the aircraft.

- (c) If a descending aircraft must level off at 10 000 ft ASL to comply with CAR 602.32 while cleared to a lower level, the pilot should advise ATC of the descent interruption.
- (d) ATC may authorize aircraft to employ cruise climb techniques either between two levels or above a specified level. A clearance or instruction to cruise climb authorizes climb at any given rate as well as temporarily levelling at intermediate altitudes. Pilots are expected to advise ATC of the altitude they temporarily level off at to the nearest 100 ft. Once the aircraft has vacated an altitude during a cruise climb, it may not return to that altitude. ATC will use the following phraseology:

CRUISE CLIMB TO (altitude)

or

CLIMB TO (altitude) CRUISE CLIMB BETWEEN (levels) (or ABOVE [level])

8.4.2 Visual Climb and Descent

8.4.2.1 General

Application of visual climbs and descents in VMC, under certain circumstances, provides both controllers and pilots with an operational advantage in the conduct of safe and orderly flow of air traffic.

8.4.2.2 Visual Separation from Other Aircraft

ATC may authorize the pilot of an IFR aircraft to conduct a visual climb or descent while maintaining visual separation with the appropriate traffic only if a pilot requests it. Controllers will not initiate or suggest a visual climb/descent in this application. During this altitude change in VMC, pilots must provide their own separation, including wake turbulence separation, from all other aircraft. This application may be exercised in both ATS surveillance and non-ATS surveillance environments.

IFR separation is required for all altitude changes in Class A and B airspace. Accordingly, visual climbs or descents will not be approved for aircraft operating in these classes of airspace.

8.5 Minimum Instrument Flight Rules (IFR) Altitudes

Except when taking off or landing, aircraft in IFR flight shall be operated at least 1 000 ft above the highest obstacle within a horizontal radius of 5 NM of the aircraft (CAR 602.124). Exceptions to this are flights within designated mountainous regions, but outside areas for which minimum altitudes for IFR operations have been established (see RAC 2.12 and RAC Figure 2.10).

NOTE:

The established MOCA for IFR operations provides obstacle clearance above the highest obstacle within the following areas:

- (a) **1 000 ft:**
 - (i) airways and air routes outside of designated mountainous areas;
 - (ii) certain airway and air route segments within designated mountainous areas, which are used in the arrival or departure phase of flight;
 - (iii) Safe Altitude 100 NM outside of designated mountainous areas;
 - (iv) all MSA;
 - (v) instrument approach transitions (including DME arcs);
 - (vi) vectoring areas [except as in (c)(iii)]; and
 - (vii) AMA outside of designated mountainous areas as shown on the Enroute and Terminal Area Charts.
- (b) **1 500 ft:**
 - (i) airways and air routes within designated mountainous areas 2, 3, and 4; or
 - (ii) Safe Altitude 100 NM within designated mountainous areas 2, 3, and 4.
- (c) **2 000 ft:**
 - (i) airways and air routes within designated mountainous areas 1 and 5 with the exception of those segments described in (a)(ii);
 - (ii) Safe Altitude 100 NM within designated mountainous areas 1 and 5;

- (iii) certain vectoring areas within designated mountainous areas; and
- (iv) AMA within designated mountainous areas as shown on the Enroute and Terminal Area Charts.

MEAs have been established for all designated low-level airways and air routes in Canada. An MEA is defined as the published altitude ASL between specified fixes on airways or air routes, which assures acceptable navigational signal coverage, and which meets IFR obstacle clearance requirements.

The minimum flight plan altitude shall be the nearest altitude or flight level consistent with the direction of flight (CAR 602.34). This altitude should be at or above the MEA. Unless the MEA is one which is consistent with the direction of flight, it is not to be used in the flight plan or flight itinerary.

As different MEAs may be established for adjoining segments of airways or air routes, aircraft are, in all cases, to cross the specified fix at which a change in the MEA takes place, at the higher MEA.

To ensure adequate signal coverage, many of the MEAs on low-level airways are established at altitudes which are higher than those required for obstacle clearance. When this occurs, a MOCA is also published to provide the pilot with the minimum IFR altitude for obstacle clearance. A MOCA is defined as the altitude between radio fixes on low-level airways and air routes, which meets the IFR Air routes clearance requirements for the route segment. Where the MOCA is lower than the MEA, the MOCA is published in addition to the MEA on the Enroute Charts. Where the MEA and MOCA are the same, only the MEA is published.

The MOCA, or the MEA when the MOCA is not published, is the lowest altitude for the airway or air route segment at which an IFR flight may be conducted under any circumstances. These altitudes are provided so that pilots will be readily aware of the lowest safe altitude that may be used in an emergency, such as a malfunctioning engine or icing conditions. Under ISA conditions, they provide a minimum of 1 000 ft of clearance above all obstacles lying within the lateral limits of all airways and air routes and 1500/2000 ft in designated mountainous regions.

Pressure altimeters are calibrated to indicate true altitude under ISA conditions, and any deviation from ISA will result in an erroneous altimeter reading. When temperatures are extremely cold, true altitudes will be significantly lower than indicated altitudes. Although pilots may fly IFR at the published MEA/MOCA, in the winter, when air temperatures are much lower than ISA, they should operate at altitudes of at least 1 000 ft above the MEA/MOCA.

NOTE:

When flying at a flight level in an area of low pressure, the true altitude will always be lower than the corresponding flight level. For example, this “pressure error,” in combination with a temperature error, can produce errors of up to 2 000 ft while flying in the standard pressure region at FL 100. Further, mountain waves in combination with extremely low temperatures may result in an altimeter over-reading by as much as 3 000 ft. For further details, see AIR 1.5.

8.6 Air Traffic Control (ATC) Assignment of Altitudes

8.6.1 Minimum Instrument Flight Rules (IFR) Altitude

Within controlled airspace, ATC is not permitted to approve or assign any IFR altitude below the minimum IFR altitude. To ATC, the minimum IFR altitude is the lowest IFR altitude established for use in specific airspace and, depending on the airspace concerned, this may be:

- (a) a minimum en route altitude (MEA);
- (b) a minimum obstacle clearance altitude (MOCA);
- (c) a minimum sector altitude (MSA);
- (d) a safe altitude within a radius of 100 NM;
- (e) an area minimum altitude (AMA); or
- (f) a minimum vectoring altitude (MVA).

When a direct route is given, ATC is responsible for obstacle clearance. Provided that the altitude is at or above the minimum IFR altitude for the controlled airspace where the pilot intends to operate, ATC may use “direct” in a route clearance. ATC may clear aircraft that are traversing airways or air routes below the MEA, but not below the applicable minimum IFR altitude.

Within ATS surveillance coverage, it is common for controllers to issue the MVA when issuing direct routes. An MVA can be lower than a published minimum IFR altitude (MSA, MOCA, MEA, or AMA).

All ATC-assigned altitudes provide obstacle clearance.

A controller is not permitted to clear an aircraft flying on an airway at an altitude below the MEA. However, flight below the MEA, but not below the MOCA, may be approved when specifically requested by the pilot in the interest of flight safety (e.g. icing/turbulence), to conduct a flight check, for MEDEVAC, or when navigating using GNSS.

Navigational signal coverage is not guaranteed below the MEA; when navigating using NAVAIDS, the pilot should ensure that the aircraft is within, and will remain within, the lateral limits of the airway before requesting approval to fly below the MEA. It should also be noted that flight below the MEA does not guarantee the aircraft will remain in controlled airspace.

8.6.1.1 Distance Measuring Equipment (DME) Intersections on a Minimum En-Route Altitude (MEA)

The purpose of these fixes is to develop an airway segment where lower MEAs may be applied, thus reducing the high descent rates that otherwise are required when the aircraft is on initial approach to destination.

Pilots without DME normally will not be able to use these lower MEAs and may conceivably experience delays in receiving approach and departure clearances due to other traffic operating below the conventional MEA (i.e. the MEA required for non-DME-equipped aircraft). However, in an ATS surveillance

environment, the non-DME-equipped aircraft may be cleared at the lower MEA where it will be provided with ATS surveillance service while operating below the conventional MEA.

8.6.2 Altitudes and Direction of Flight

Pilots will normally file flight plans and be assigned altitudes appropriate to the airway, air route or direction of flight. There are exceptions, and the following information is intended to familiarize pilots with the circumstances of those exceptions.

ATC may assign an altitude that is not appropriate to the airway, air route or direction of flight if:

- (a) a pilot requests it because of icing, turbulence, or fuel considerations, provided:
 - (i) the pilot informs ATC of the time or location at which an appropriate altitude can be accepted, and
 - (ii) the altitude has been approved by affected units/sectors; or
- (b) an aircraft is:
 - (i) holding, arriving or departing;
 - (ii) conducting a flight inspection of a NAVAID;
 - (iii) operating within an altitude reservation;
 - (iv) engaged in an aerial survey, mapping flight or test flight;
 - (v) operating on a polar route; or
- (c) no alternative separation minima can be applied, provided:
 - (i) the altitude has been approved by affected units/sectors, and
 - (ii) the aircraft is cleared to an appropriate altitude as soon as possible;
- (d) the airspace is structured for a one-way traffic flow.

NOTES:

1. In situation (a), the pilot, when able to accept an appropriate altitude, will be requested to advise ATC. In situation (c), the aircraft will be re-cleared to an appropriate altitude as soon as operationally feasible. Due to safety implications, use of altitudes inappropriate for the direction of flight must be limited, and requests must not be made solely for fuel efficiency reasons. Pilots should make requests only to avoid a fuel situation that might cause an otherwise unnecessary refuelling stop short of the flight-planned destination. ATC will not ask the pilot to substantiate a request; if ATC is unable to approve the request, the controller will state the reason and request the pilot's intention.
2. In the application of (a) or (c) in high-level ATS surveillance-controlled airspace, aircraft at an altitude not appropriate for the direction of flight will be issued vectors or offset tracks to establish the aircraft at least 5 NM from the centreline of an airway or published track displayed on the situation display.

Phraseology:

VECTORS TO (direction) OF (airway, track) TURN (left/right) TO HEADING (degrees).

ADVISE IF ABLE TO PROCEED PARALLEL OFFSET.

PROCEED OFFSET (number) MILES (right/left) OF CENTRELINE (track/route) AT (significant point/time) UNTIL (significant point/time).

CANCEL OFFSET.

8.7 “1 000-ft-on-Top” Instrument Flight Rules (IFR) Flight

1 000-ft-on-top IFR flight may be conducted provided that

- (a) the flight is made at least 1 000 ft above all cloud, haze, smoke, or other formation;
- (b) the flight visibility above the formation is at least three miles;
- (c) the top of the formation is well defined;
- (d) the altitude appropriate to the direction of flight is maintained when cruising in level flight;
- (e) the “1 000-ft-on-top” flight has been authorized by the appropriate ATC unit; and
- (f) the aircraft will operate within Class B airspace at or below 12 500 ft ASL, Class C, D, or E airspace.

NOTE:

ATC does not apply separation to aircraft operating 1 000-ft-on-top except in the following conditions:

1. at night, separation is applied between an aircraft operating 1 000-ft-on-top and other aircraft if any of the aircraft are holding; and
2. between aircraft operating 1 000-ft-on-top and an aircraft operating on an altitude reservation approval.

8.8 Clearances—Leaving or Entering Controlled Airspace

ATC will use the phrase “while in controlled airspace” in conjunction with the altitude if an aircraft will be entering or leaving controlled airspace. In addition, ATC will specify the lateral point and altitude at which an aircraft is to leave or enter controlled airspace if the instruction is required for separation purposes (see Note).

Example:

LEAVE/ENTER CONTROLLED AIRSPACE (number) MILES (direction) OF (fix) AT (altitude).

LEAVE/ENTER CONTROLLED AIRSPACE AT (altitude).

NOTE:

The altitude assigned by ATC need only reflect the minimum safe IFR altitude within controlled airspace. A pilot should be alert to the possibility of a higher minimum safe IFR altitude outside of controlled airspace. If uncertain (or unable to

determine) when to enter or leave the area where the higher minima is applied, a request for clearance to maintain an altitude that will accommodate the higher minimum IFR altitude should be made.

8.9 Clearance Limit

The clearance limit, as specified in an ATC clearance, is the point to which an aircraft is cleared. Further clearance is delivered to a flight prior to arrival at the clearance limit. However, occasions may arise when this may not be possible. In the event that further clearance is not received, the pilot is to hold at the clearance limit, maintain the last assigned altitude and request further clearance. If communications cannot be established with ATC, the pilot should then proceed in accordance with communications failure procedures as described in RAC 6.3.2.

The responsibility rests with the pilot to determine whether or not a received clearance can be complied with in the event of a communications failure. Under such circumstances, a clearance may be refused, but such refusal should specify acceptable alternatives.

8.10 Class G Airspace—Recommended Operating Procedures—En-Route

When aircraft are manoeuvring in the vicinity of uncontrolled aerodromes or cruising in Class G airspace, the lack of information on the movements of other aircraft operating in close proximity may occasion a potential hazard to all concerned. To alleviate this situation, all pilots are advised that:

- (a) when operating in Class G airspace, they should continuously monitor frequency 126.7 MHz whenever practicable;
- (b) position reports should be made over all NAVAIDs along the route of flight to the nearest station having air-ground communications capability. These reports should be made on frequency 126.7 MHz whenever practicable. If it is necessary to use another frequency to establish communications with the ground station, the report should also be broadcast on 126.7 MHz for information of other aircraft in the area. The report should contain present position, track, altitude, altimeter setting in use, next position and ETA;
- (c) immediately before changing altitude, commencing an instrument approach or departing IFR, pilots should broadcast their intentions on 126.7 MHz whenever practicable. Such broadcasts should contain adequate information to enable other pilots to be fully aware of the position and intentions so that they can determine if there will be any conflict with their flight paths;
- (d) at aerodromes where an MF has been designated, arriving pilots shall first broadcast their intentions on 126.7 MHz before changing to the MF. If conflicting IFR traffic becomes evident, this change should be delayed until the conflict is resolved. Pilots departing IFR should broadcast their intentions on 126.7 MHz, in addition to the MF, prior to takeoff; and

- (e) the preceding reporting requirements are considered as the minimum necessary. Pilots are encouraged to make additional reports whenever the possibility of conflicting IFR traffic is suspected. An example would be reporting prior to overflying a facility where cross traffic is probable or where there is a published instrument approach procedure.

NOTE:

There is no frequency comparable to 126.7 MHz for use by aircraft equipped only with UHF; however, pertinent UHF traffic information will be relayed on the MF by the flight service specialist.

9.0 Instrument Flight Rules (IFR) — Arrival Procedures

9.1 Automatic Terminal Information Service (ATIS) Broadcasts

If ATIS is available, all pilots should use it to obtain the basic arrival or departure and aerodrome information as soon as it is practicable.

9.2 Standard Terminal Arrival (STAR), Minimum Sector Altitude (MSA) and Terminal Arrival Area (TAA)

The objective of the standard terminal arrival (STAR), the minimum sector altitude (MSA) and the terminal arrival area (TAA) depictions is to provide arriving aircraft with a seamless transition from the en route structure to the terminal environment.

Unlike the MSAs and TAAs, the STARs are developed to simplify clearance procedures at higher density airports and are individually depicted in the *Canada Air Pilot* (CAP). The MSA and TAA depictions are also in the CAP, but are found in the plan view of the associated approach chart.

A STAR requires the pilot to follow a predetermined route, whereas the MSA and the TAA are less prescriptive and simply offer safe altitudes to which the pilot can descend before commencing the approach. Pilots are to review each STAR issued and to follow the procedure as published. If there is any doubt as to what is required, clarification should be obtained from air traffic control (ATC). Pilots are not required to accept a STAR clearance, and, if they are unable to follow it, they should request alternate instructions.

9.2.1 Minimum Sector Altitude (MSA)

The MSA, as depicted on the approach chart (see the CAP), provides a minimum of 1 000 ft clearance above all obstacles within a sector of a circle having a radius of at least 25 NM centred on a radio aid to navigation or on a waypoint located near the aerodrome. Where required, the depiction may be divided into several pie-shaped sectors of varying minimum altitudes. Pilots can locate their sector by superimposing their track to the selected NAVAID onto the MSA depiction.

Unlike TAA depictions, MSA depictions do not allow the sectors to be further partitioned into step-down arcs of varying distances.

NOTE:

MSAs are not flight-inspected. Therefore, MSAs based on conventional NAVAIDs may not necessarily assure acceptable navigational signal coverage throughout the 25-NM radius area.

RNAV approaches may use either an MSA or a TAA depiction. RNAV approaches that use the MSA shall depict the common minimum altitude only.

9.2.2 Terminal Arrival Area (TAA)

TAAAs are developed for aircraft equipped for RNAV based navigation.

When a TAA is published, it replaces the MSA depiction on the approach chart (see the CAP).

The main advantage of the TAA over the MSA is that it can allow step-down arcs, based on RNAV distances, within its divided areas. This allows the aircraft to descend to lower minimum altitudes while still providing a minimum clearance of 1 000 ft above all obstacles.

The standard TAA consists of three areas which are defined by the extension of the initial and intermediate approach segments. These are called the straight-in areas, left-base areas and right-base areas.

The procedure underlying the TAA is normally the “T” design (also called the “Basic T”) which includes:

- two IAFs on left and right base legs
- a dual-purpose IF/IAF in the center, which serves as both an initial and an intermediate fix
- an HILPT at the IF/IAF, used when alignment or descent is needed

Figure 9.1: Example of standard TAA areas in Basic T

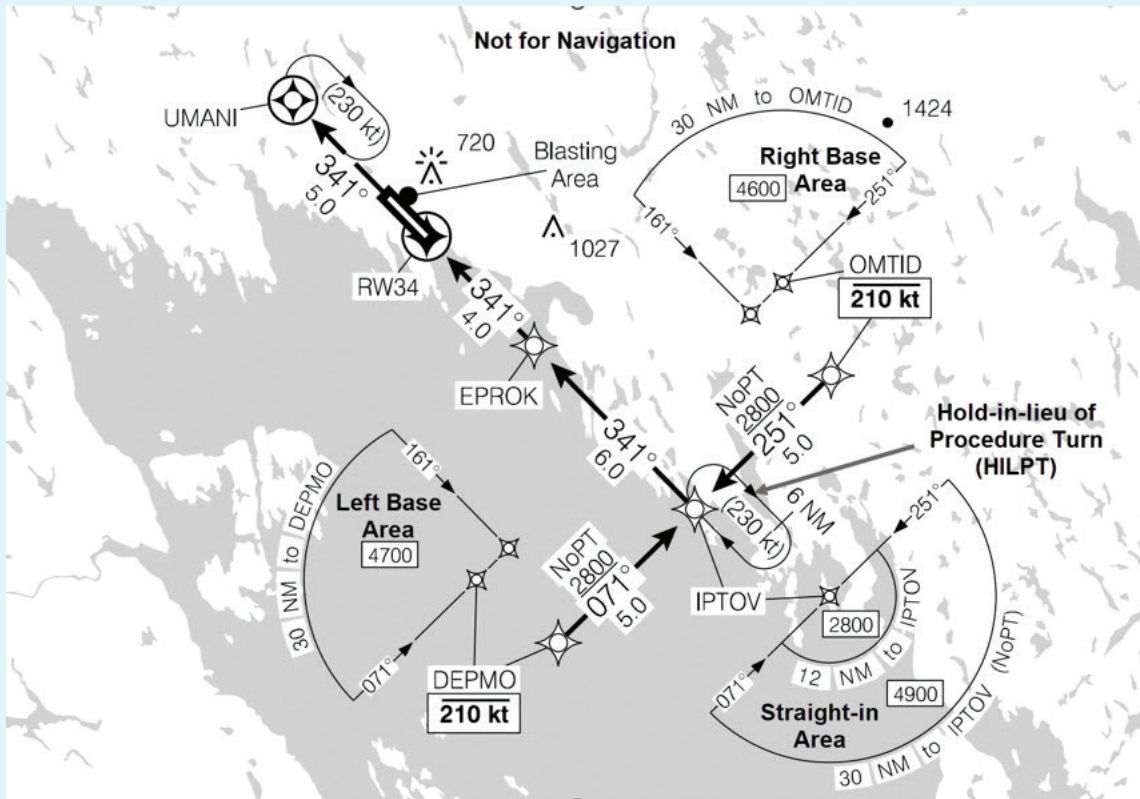

The lateral boundaries of each TAA area are identified by magnetic courses to the associated IF/IAF (true courses in NDA). The straight-in area can be further divided into pie-shaped sectors with the boundaries identified by courses to the IF/IAF and may contain stepdown sections defined by arcs based on RNAV distances from the IF/IAF (see Figure 9.2 below). The right/left-base areas can only be subdivided using arcs based on RNAV distances from the IAFs for those areas (see Figure 9.2 below).

Figure 9.2: TAA example with true courses

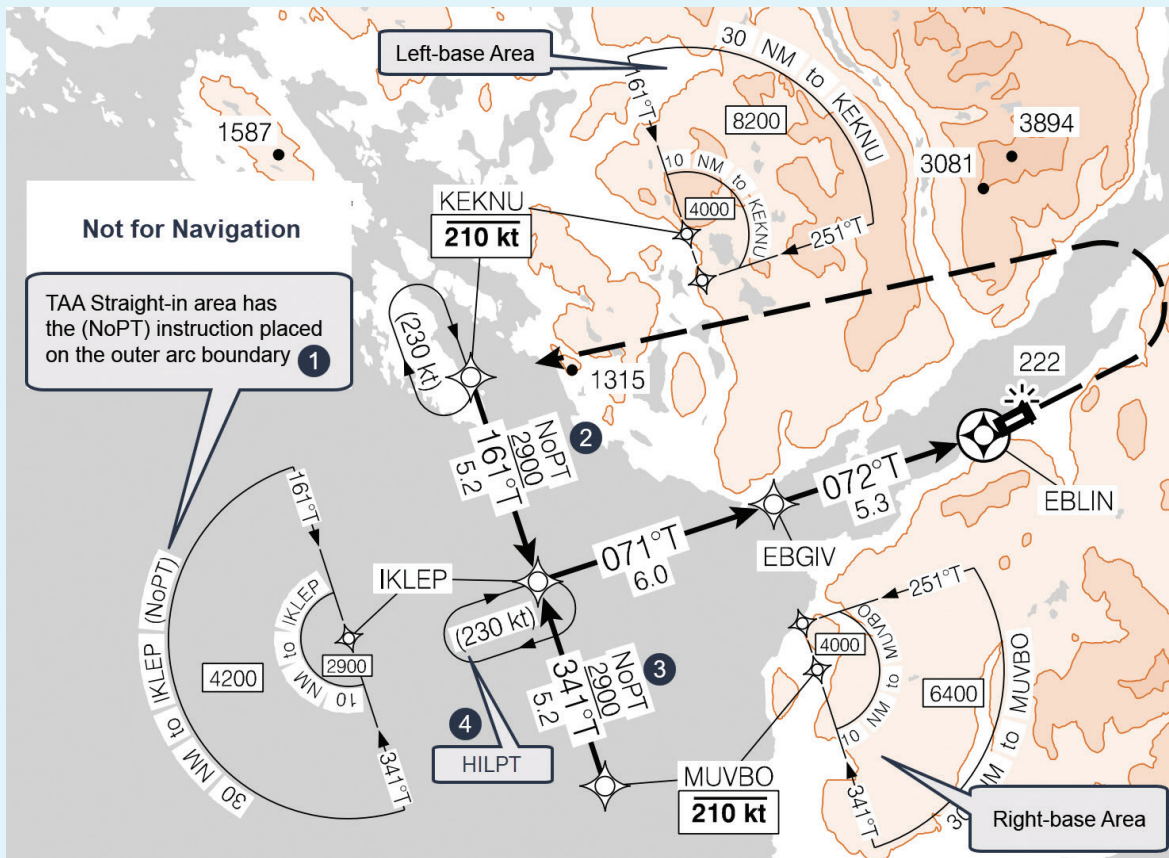

Entry Types (see Figure 9.3):

Straight-in Area:

Aircraft approaching from the **090° to 270° bearing** (to the IF/IAF) can proceed **direct to the IF/IAF**.

No course reversal is required—this is indicated by a “**NoPT**” label on the outer arc.

Left-base Area:

Aircraft approaching from the **270° to 360° bearing** (to the left-base IAF) can proceed **direct to the left-base IAF**.

No HILPT is required if flying the published segment—marked with “**NoPT**.”

Right-base Area:

Aircraft approaching from the **360° to 090° bearing** (to the IF/IAF) must **execute the HILPT** at the IF/IAF.

This ensures proper alignment and descent rate before entering the intermediate segment.

NOTES:

“**NoPT**” means no procedure turn (including HILPT) is required in that sector.

If not flying the published segment (e.g., direct to IF/IAF from base areas), the pilot **must fly the HILPT**, unless otherwise cleared.

Step-down fixes and **sector boundaries** may be defined by RNAV distances or bearings.

Figure 9.3: Example of TAA Area Sectorization with Elimination of Right Base Area; NoPT Exclusion

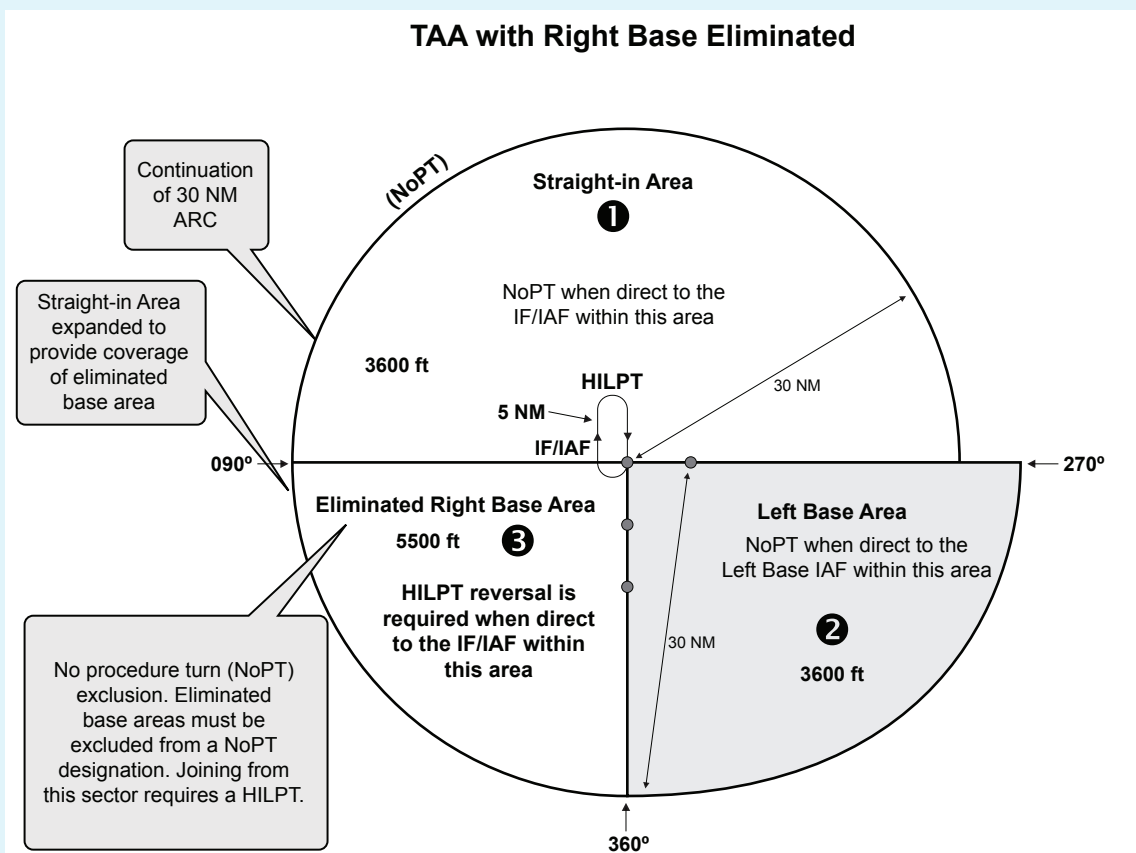
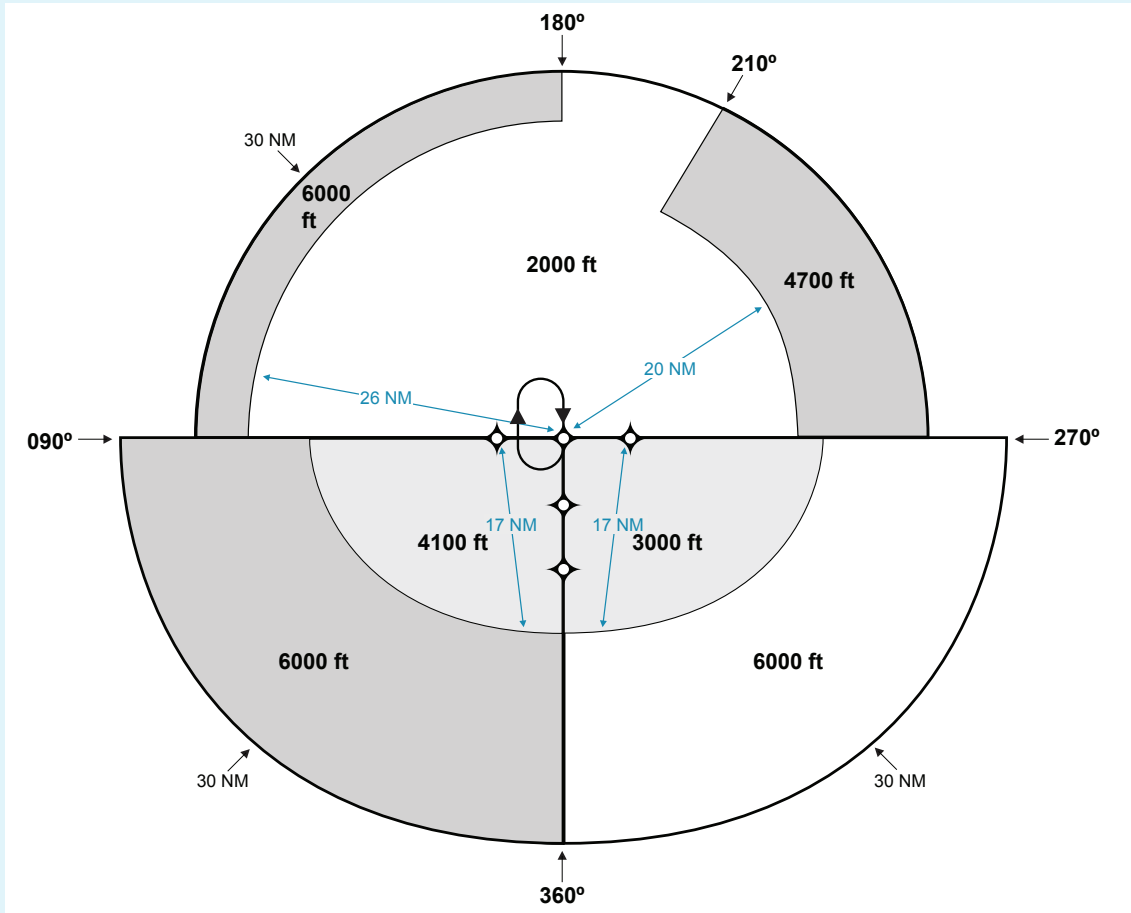

Figure 9.4: Example of TAA Radial Sectorization and Stepdown Arcs



Entry from the TAA into the instrument procedure is normally accomplished via a NoPT routing (i.e., via a published initial segment) or via a course reversal maneuver (i.e., HILPT) at the IF/IAF. The published procedure will be annotated “NoPT” to indicate when the course reversal is not required when flying within a particular TAA sector. Otherwise, the pilot is expected to execute the course reversal. The pilot may elect to use the course reversal pattern when it is not required by the procedure but must advise ATC and/or broadcast intentions as applicable.

Before beginning the procedure, see Figure 9.3 above:

1. (Figure 9.3) Pilots operating within the TAA between the 090 bearing clockwise to the 270 bearing to the IF/IAF are expected to proceed direct to the IF/IAF and not execute a course reversal maneuver.
2. (Figure 9.3) No HILPT is required in the left-base area (from 270 bearing clockwise to the 360 bearing to the left-base IAF) if proceeding direct to the left-base IAF.
3. (Figure 9.3) Aircraft operating in the area from 360 bearing clockwise to the 090 bearing to the IF/IAF are expected to proceed direct to the IF/IAF and execute the HILPT course reversal in order to properly align the aircraft for entry onto the intermediate segment or to avoid an excessive descent rate.

ATC should not clear an aircraft to the left-base leg or right-base leg IAF within a TAA at an intercept angle exceeding 90 degrees.

ATC may clear aircraft direct to the fix labeled IF/IAF if the course to the IF/IAF is within the straight-in sector.

ATC may clear the aircraft for an approach at the airport (for example, “cleared to the swift current airport for an approach”) without specifying a particular IAF. The pilot is expected to proceed directly to the IAF or to the IF/IAF associated with the sector that the aircraft will enter the TAA and join the approach course from that point. If that sector is not labelled “NoPT”, complete the HILPT course reversal. See the figure above.

NOTE:

If approaching to a bearing that is on a sector boundary, the pilot is expected to proceed in accordance with a “NoPT” routing.

TAA altitudes provide at least 1 000 ft of obstacle clearance. The pilot can determine which area of the TAA the aircraft will enter by determining the magnetic bearing of the aircraft to the fix labeled IF/IAF. The bearing should then be compared to the published lateral boundary bearings that define the TAA areas. Do not use magnetic bearing to the right-base or the left-base IAFs to determine sector.

Once cleared for the approach, pilots may descend in the TAA sector to the minimum altitude depicted within the defined area/subdivision, unless instructed otherwise.

TAAAs may be modified from the standard size and shape to accommodate airspace requirements. Some areas may be eliminated, while the other areas are expanded. The “T” design may appear more like an upside down “L” or an “I.”

In a TAA where both Left and Right base areas are eliminated, pilots approaching on a bearing to the IF/IAF from the ‘straight-in’ area are not expected to execute the HILPT. Pilots approaching from outside the straight-in area (271 clockwise to 089 in this example) are expected to execute a HILPT because the amount of turn required at the IF/IAF exceeds 90 degrees. The term “NoPT” will be annotated on the outer boundary of the TAA icon for the straight-in area of the TAA.

Figure 9.5: Example of TAA Left and Right-base Areas Eliminated

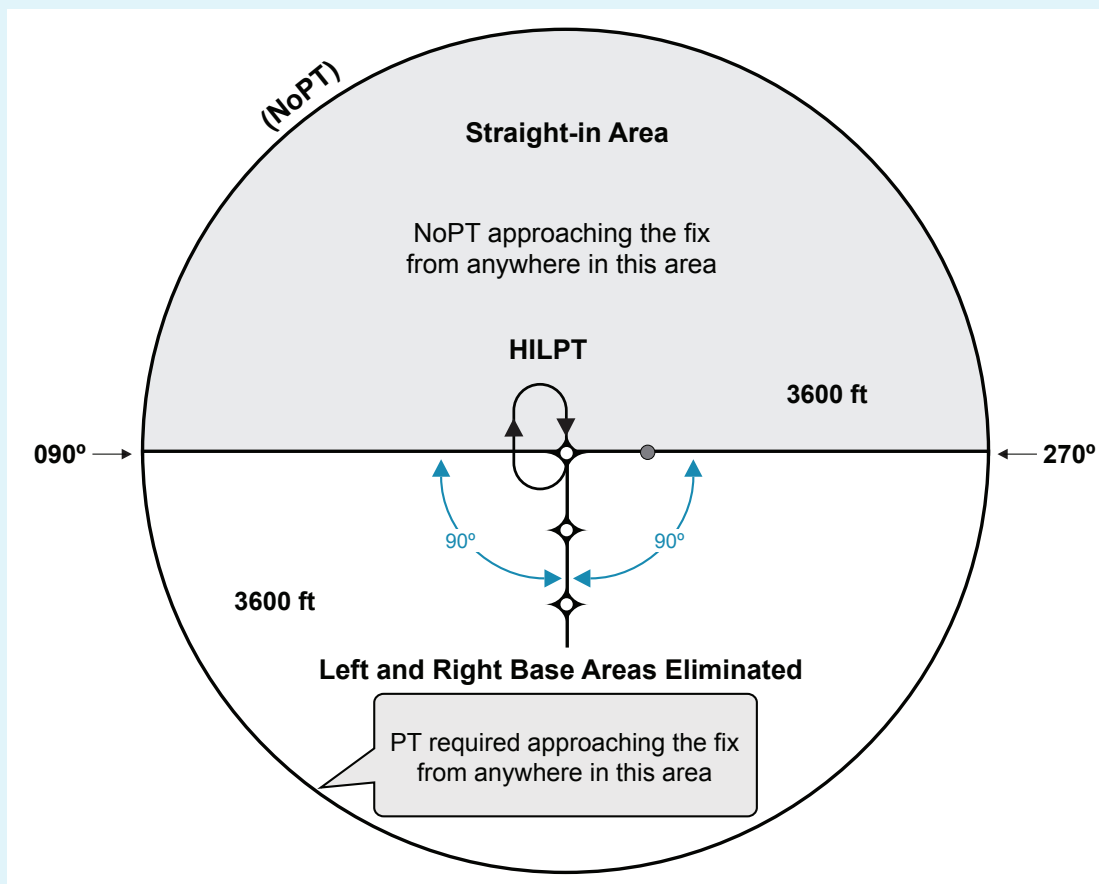

TAA modification may also eliminate a left or right-base area and part of the straight-in area. In Figure 9.6, the left-base area and part of the straight-in area have been eliminated. ❶ Pilots operating between the 210° bearing clockwise to 360 bearing to the IF/IAF are expected to proceed direct to the IF/IAF and then execute the course reversal to align the aircraft for entry onto the intermediate segment or avoid an excessive descent rate. ❷ Aircraft operating in the area between 360° clockwise to 090° bearing to the right-base IAF are expected to proceed direct to the fix and not execute a course reversal maneuver (NoPT text will be associated with the initial right segment). Aircraft cleared direct the IF/IAF by ATC in this sector will be expected to accomplish a HILTP. ❸ Aircraft operating in areas between 090 clockwise to 210° bearing to the IF/IAF are expected to proceed direct to the IF/IAF and not execute the course reversal.

Figure 9.6: TAA Example with Left Base and part of Straight-in Area Eliminated

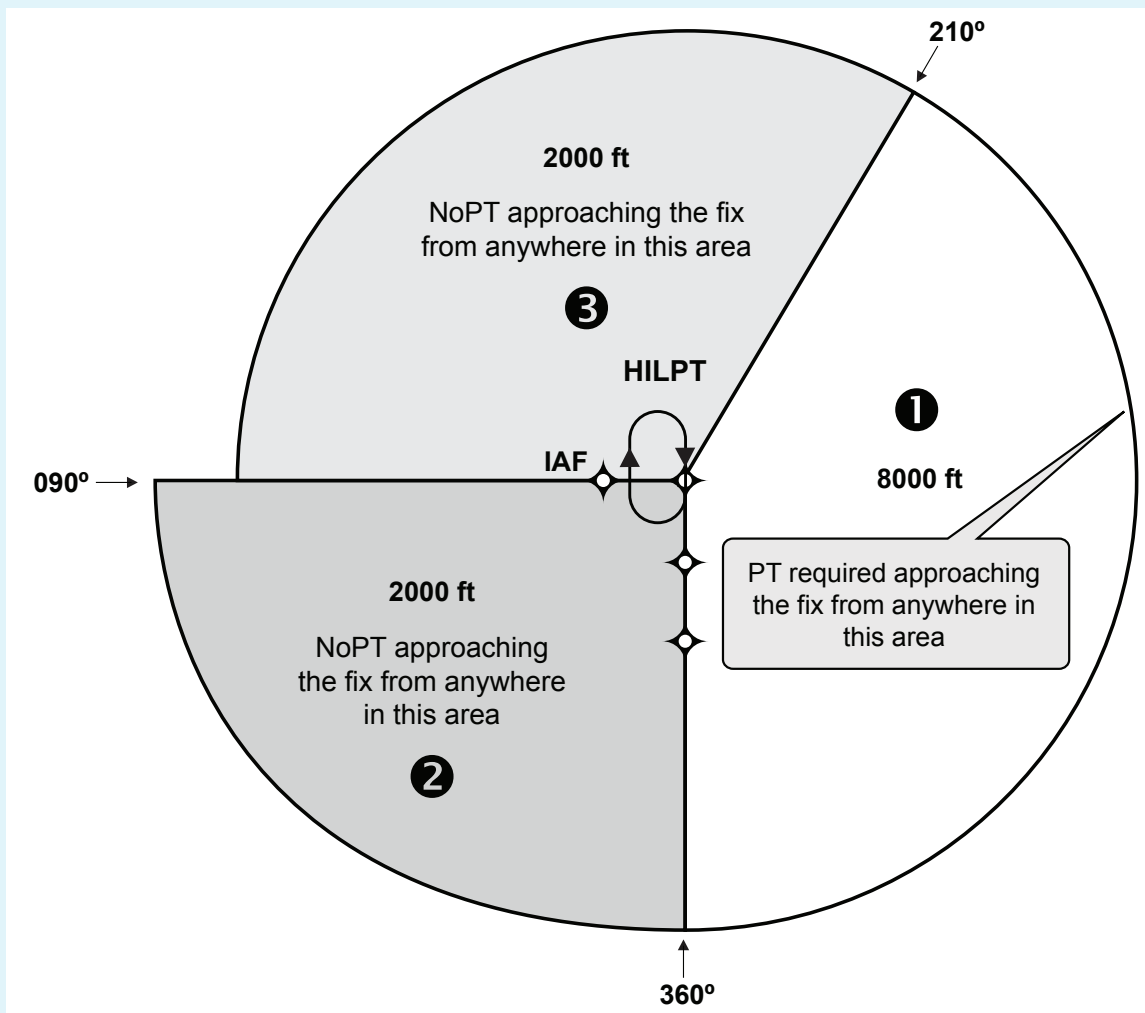

NOTE:
Early TAA designs did not depict the 'NoPT' textual instruction.

CAUTION:
When no HILPT is depicted, the associated holding pattern area has not been assessed. If required, any maneuvering for course reversal must be accomplished within the straight-in area, at or above the charted sector altitude.

9.2.3 Standard Terminal Arrival (STAR)

A STAR is an ATC IFR arrival procedure published in the CAP for use by aircraft with the appropriate navigation capabilities and is coded in many GNSS and FMS databases.

STARs provide the following benefits:

- (a) **Predictability for flight crews:** As opposed to vectors, STARs allow pilots to be aware in advance of arrival routings and plan more optimum descent profiles.
- (b) **Facilitation of clearances and radiotelephony exchanges:** Published STARs reduce the need to communicate detailed descent, speed, and track instructions.
- (c) **Increased predictability for ATC:** Controllers observe more consistent aircraft track-keeping and turn performance on STARs due to published speed and altitude restrictions.

9.2.3.1 Conventional Standard Terminal Arrival (STAR)

A conventional STAR can be flown using ground-based NAVAIDS and/or charted headings and traditionally ends with ATC providing vectors. Pilots who request a conventional STAR are expected to have sufficient navigation equipment to fly the procedure. Canadian conventional STARs are gradually being replaced with PBN STARs.

9.2.3.2 Performance-based Navigation (PBN) Standard Terminal Arrival (STAR)

With the widespread deployment of PBN, even greater benefits are now possible in STAR design. PBN STARs thus permit an increase in flight safety as well as potential fuel savings. When used by qualified aircraft and operators, a PBN STAR can result in greater reliability, repeatability, and predictability of aircraft flight paths.

A PBN STAR is titled “STAR (RNAV)” and is a performance-based operation in which the performance requirements are specified by the publication of a navigation specification (such as RNAV 1 or RNP 1) on the chart in the PBN requirements box. Detailed explanations of navigation specifications can be found in COM 6.0.

In cases where a navigation specification has not yet been assigned to a PBN STAR, the following equipment would be required:

- (a) at least one RNAV system or FMS certified for terminal use that meets either of the following standards:
 - (i) AC 20-130 (or later approved) *Airworthiness Approval of Navigation or Flight Management Systems Integrating Multiple Navigation Sensors*; or
 - (ii) AC 20-138 (or later approved) *Airworthiness Approval of Global Positioning System (GPS) Navigation Equipment for use as a VFR and IFR Supplemental Navigation System*, and
 - (iii) TSO C129a, *Airborne Supplemental Navigation Equipment Using the Global Positioning System (GPS)*;
- (b) at least one automatic radio-updated IRU, if the RNAV system or FMS does not use a GPS sensor;
- (c) a current database containing the waypoints, for the STAR to be flown, that can be automatically loaded into the RNAV system or FMS active flight plan;
- (d) a system capable of following the RNAV system or FMS lateral flight path and limiting the cross-track error deviation to +/- ½ the navigation accuracy associated with the procedure or route; and
- (e) an electronic map display.

9.2.3.3 Flight Planning

Authorized aircraft and air operators who meet the appropriate navigation specification (or the equipment list shown above for STARs without a navigation specification) may file STARs in their flight plan. Operators not authorized to flight plan PBN STARs are expected to file plans that include waypoints from the expected STAR procedure (or plans that are as close to the waypoints as possible), and include the remark in field 18 of the flight plan: RMK/NO RNAV STAR.

When included in a flight plan, the STAR will form part of the flight-planned route in the ATC clearance.

NOTE:

Mandatory IFR Routes may include a STAR. See RAC 11.4.3.

9.2.3.4 Procedure Identification

A STAR can designate multiple lateral routes, dependent on the runway in use, for an aircraft to fly from various points along the en route phase of flight to the approach phase with little or no ATC intervention. These lateral routes (referred to as transitions) are listed on the STAR chart and may include instructions for management of the vertical profile. The procedure identification on a STAR chart includes the primary procedure identification and the en route transition identification.

The primary procedure identification consists of the following three elements:

- (a) Procedure type
- (b) Plain-language designator
- (c) Coded designator

The procedure type is shown as one of the following:

- (a) STAR: identifies the procedure as a conventional STAR
- (b) STAR (RNAV): identifies the procedure as a PBN STAR

The plain-language designator is the spoken identification for the STAR procedure. It consists of a basic indicator, a validity number, and the term “ARR”. The validity number is a number between one and nine assigned sequentially after a qualifying procedure amendment. Example: UDNOX ONE ARR. A qualifying procedure amendment is a change in a procedure track or another significant change affecting the database coding of the procedure.

When a STAR procedure includes transitions from the en route airspace structure, the en route transitions are identified in similar fashion to the main STAR procedure. The en route transition identification includes a plain-language designator and a coded designator. The plain-language designator is the spoken identification for the en route transition and, while not always, it is usually derived from the name of the first point of the en route transition. The coded designator is the database/flight planning identification for the en route transition and is derived from both the en route transition plain-language designator and the primary procedure identification. For example, the LETAK TRANSITION (LETAK.IMEBA3) on the IMEBA THREE ARR into CYYZ is highlighted on the chart below.

Figure 9.7—Example of an En route Transition on the IMEBA THREE ARR into CYYZ

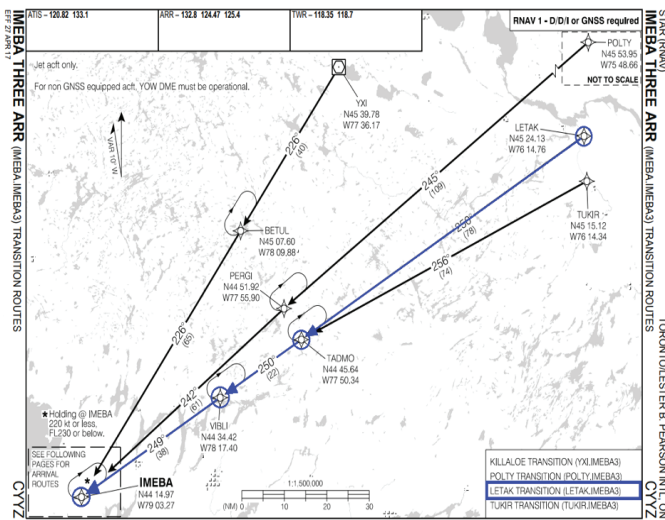

9.2.3.5 Altitude Restrictions

Altitude restrictions may be included in the STAR. Although an aircraft is expected to follow the charted lateral track of the cleared STAR without further ATC clearance, as per the flight-planned/cleared route, such is not the case with the STAR vertical profile; ATC has to issue descent clearance, and when a lower altitude is issued, pilots shall descend on the STAR profile to the ATC-assigned altitude. Unless specially cancelled by ATC, all charted restrictions above the assigned altitude on the STAR remain mandatory.

9.2.3.6 Speed Restrictions

Pilots must follow charted speed restrictions on a STAR. An ATC-assigned speed restriction supersedes any STAR-charted speed restrictions and must be followed until CAR 602.32 prohibits the pilot from flying at that speed.

9.2.3.7 Operating Procedures

When included in a flight plan, the STAR forms part of the flight-planned route received in the initial ATC clearance. When a flight plan that includes a STAR has been filed, or when the pilot receives and acknowledges a clearance that includes a STAR, the pilot is expected to fly the charted lateral track without further clearance. However, descent clearance must be obtained from ATC before commencing the vertical profile.

9.2.3.8 Top of Descent (TOD)

Sophisticated FMSs have the ability to determine precisely where to begin a descent from cruise altitude in order to minimize fuel usage, pollution, and noise by having the engines at their minimum thrust setting (idle) from cruise altitude to the final approach fix. This point is known as TOD. The most recent Canadian STAR procedures are carefully designed to allow the greatest benefits from idle descents while meeting the most common ATC requirements.

In order to maintain safety and airspace capacity, ATC may have to issue tactical instructions such as interim altitudes, speed control, vectors, or direct routes. Tactical instructions impact the TOD planning carried out by the FMS. For instance, delaying the planned descent, reducing the speed, or shortcutting STAR intermediate waypoints translate into a steeper descent angle, requiring the use of speed brakes and/or a longer flying distance. A premature descent clearance will translate into a shallower descent angle, requiring the use of engine thrust. To help mitigate the impact of these tactical instructions, ATC will endeavour to cancel or assign altitude and speed restrictions as far in advance as possible to help the flight crew re-optimize the descent.

In some terminal areas, the en route controller may issue initial descent instructions at TOD, but it may be an arrival controller who could ultimately be responsible for sequencing aircraft to the final approach course. Pilots should always state their requested approach when making initial contact with the controller who will be responsible for sequencing the aircraft to the final approach course, even if the initial descent clearance was issued by another controller.

9.2.3.9 Descent Planning

Some PBN instrument approach procedures require fewer track miles to be flown, necessitating STAR vertical profiles significantly lower than those required for other approaches.

There are two main classifications of PBN approach procedures (see COM 6.0):

- (a) Required navigation performance approach (RNP APCH) procedures, bearing the chart title “RNAV (GNSS)”
- (b) Required navigation performance authorization required approach (RNP AR APCH) procedures, bearing the chart title “RNAV (RNP)”

Altitude constraints specific to RNP AR APCH are built into STAR procedures in order to enhance RNP AR APCH connectivity. While these constraints are a benefit for aircraft planning an RNP AR APCH, they are a drawback for aircraft planning other approach types, as they force them below an optimum vertical profile and may require a longer final approach segment. For maintaining the flight efficiencies of aircraft not planning an RNP AR APCH, some STAR procedures may offer guidance for descent planning.

9.2.3.10 Closed Standard Terminal Arrival (STAR) Procedures

A closed STAR procedure provides a continuous path from the en route structure and automatically joins up with the final approach course. A closed STAR terminates at the FACF. On a closed STAR, when an approach clearance is received, the pilot will continue to comply with all published altitude and speed restrictions, fly the charted track to the FACF, intercept the final approach course, and fly the straight-in approach. A closed STAR procedure is normally used when the inbound track is within plus or minus 90° of the final approach course to the runway.

ATC always strives to issue approach clearances before aircraft reach the end of closed STARs, but in very rare cases (such as a distress call in progress on the frequency, frequency congestion, or high ATC workload), this may not always be possible. In order to assure obstacle clearance throughout the STAR and the approach lateral tracks, if an aircraft were to reach the end of a closed STAR prior to the issuance of an approach clearance, the pilot would be expected to safely intercept the final approach course and fly inbound maintaining the last assigned altitude. In the extremely remote case in which the aircraft reaches the end of the final approach track and further clearance has still not been obtained, the pilot would be expected to track the lateral position of the missed approach procedure for what would have been the anticipated approach, and maintain the last assigned altitude or climb to the anticipated missed approach altitude if the missed approach altitude is higher.

9.2.3.11 Open Standard Terminal Arrival (STAR) Procedures

Similar to a closed STAR, an open STAR procedure also provides a continuous path from the en route structure but does not automatically join up with the final approach course. Open STARs are charted with an expectation of vectors and essentially place aircraft in a downwind to simplify approach sequencing. A STAR can be linked to an approach once ATC has issued an approach clearance. Unless ATC issues an approach clearance, aircraft must continue on the STAR procedure while awaiting ATC instructions. Once an approach clearance is issued, the pilot is expected to comply with any remaining STAR charted altitude and speed restrictions, intercept the final approach course using the assigned transition (or the assigned vectors), and conduct a straight-in approach. If an approach clearance is not received prior to the transition that is expected by the pilot, the aircraft will maintain the STAR as charted, and ATC will provide vectors to a point from which the aircraft can fly the straight-in approach.

Figure 9.8 — Example of a Closed STAR for Rwy 24L and 24R and an Open STAR for Rwy 06L and 06R

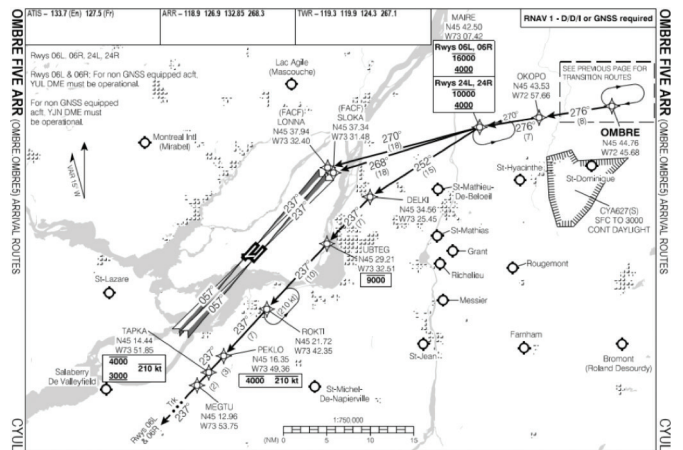

9.2.3.12 Transitioning from an Open Standard Terminal Arrival (STAR) to an Approach Procedure

The open STAR procedure normally offers the pilot an option to link the lateral profile of the STAR procedure to the lateral profile of the approach procedure through the use of a variety of approach transitions. A STAR can connect to some ILS approach procedures by using “GNSS REQUIRED” transitions published on the approach procedure. A STAR can connect to some RNP APCH (bearing the chart title “RNAV (GNSS)”) when the approach IAWP is also published on the STAR. Similarly, a STAR can connect to an RNP AR APCH (bearing the chart title “RNAV (RNP)”) when the approach IAWPs are published on the STAR. When a waypoint is published on both a STAR and an approach, it is referred to as a STAR/approach interface waypoint.

NOTE:

While it may still exist at a few airports, the connection between STAR DTW and FACF is gradually being phased out.

Figure 9.9 — CYHZ ILS RWY 23 with “GNSS REQUIRED” Left and Right IAWP to IF Transitions

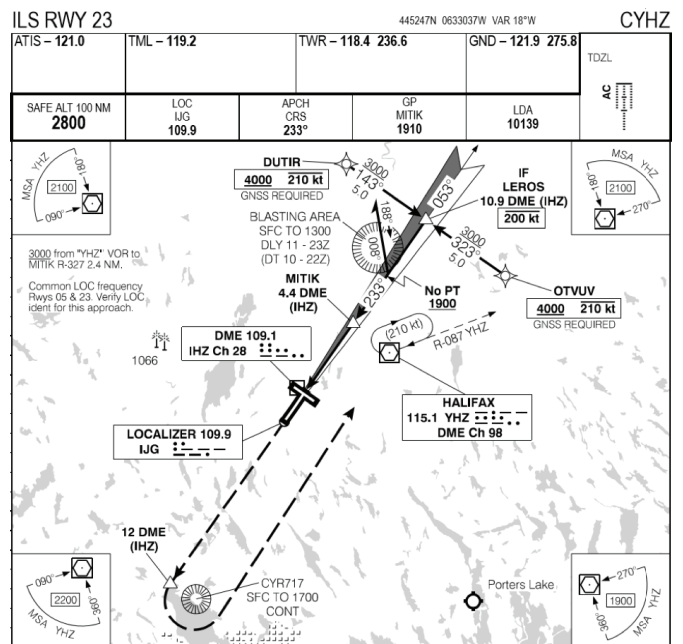

RAC

Figure 9.10 — CYHZ RNAV (GNSS) Z RWY 23 with Left and Right IAWP to IWP Transitions

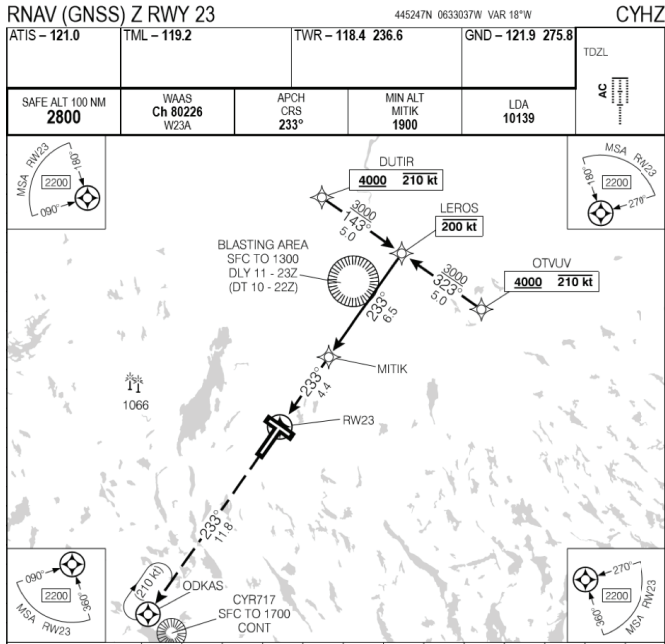
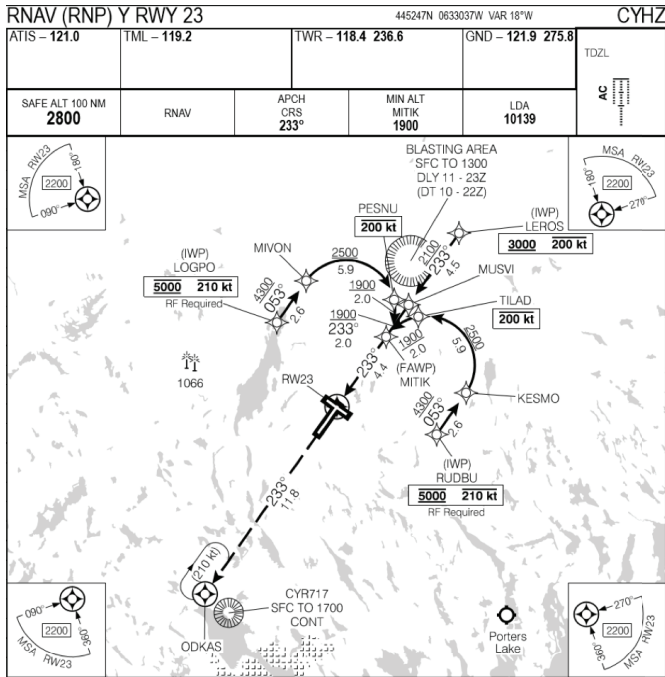

Figure 9.11 — CYHZ RNAV (RNP) Y RWY 23 with Left and Right “RF REQUIRED” IWP to FAWP Transitions



9.2.3.13 Approach Clearances

An approach clearance needs to be received prior to commencing an approach procedure; otherwise, aircraft are expected to continue flying the STAR procedure while awaiting further instructions. ATC always strives to provide transitions and early approach clearances, but sometimes traffic conditions necessitate vectors to intercept the final approach course.

Below are examples of typical FMS displays when a STAR/approach interface waypoint is used to link a STAR to an approach, both before and after an approach clearance has been issued. In both examples, before the approach clearance has

been received, a discontinuity appears in the FMS waypoint list, since linking the STAR to the approach has not yet been permitted.

Linking the STAR to the approach without ATC clearance could result in a loss of separation.

Figure 9.12 — Open STAR to RNP APPROACH

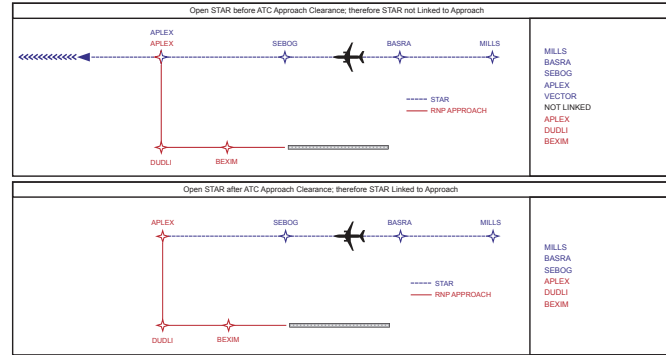
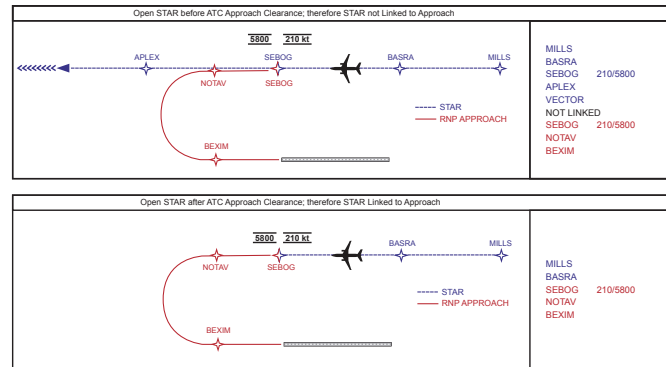

Figure 9.13 — Open STAR to RNP AR APPROACH



Once the aircraft is cleared for an approach with a specified transition, if the FMS does not link the STAR to the approach before the STAR/approach interface waypoint, or if the aircraft is unable to execute the procedure, the pilot must advise ATC immediately upon recognizing the missed transition and wait for alternate instructions.

9.2.3.14 Vectors to Final

Sometimes, depending on traffic and options for ATC to sequence aircraft, the published transition may not be available, and vectors will be provided to join the final approach course. If this occurs, and a clearance for the transition is not possible, pilots will not be expected to re-configure for a new transition or for another approach. ATC will state that they are unable to provide a particular transition and that the aircraft should expect vectors.

9.2.3.15 Amending Routes

ATC may amend STAR routes by clearing the aircraft direct to a waypoint depicted within the STAR. ATC will confirm what to expect if they intend for the aircraft to rejoin the STAR procedure when initiating vectors. When an aircraft is cleared direct to a STAR/approach interface waypoint, unless it is cleared for an approach, the pilot shall proceed direct to the STAR waypoint, and not to the approach waypoint, to re-intercept the STAR profile.

9.2.3.16 Direct Routings to an Initial Approach Waypoint (IAWP)/Intermediate Waypoint (IWP)

An RNP AR APCH (bearing the chart title “RNAV (RNP)”) normally offers RF leg segments to intercept the final approach course. Obstacle protection areas on these RF legs are designed with the consideration that the aircraft be established at the published speed and altitude, on the track centreline, and with the wings level prior to the beginning of the RF leg. The straight segment prior to these RF legs provides adequate time for aircraft to stabilize in this configuration. Direct routings to the beginning of RF leg segments are not permitted. An RNP AR APCH must not begin inside of the IWP.

9.2.3.17 Cancelling Standard Terminal Arrival (STAR) Procedures

Accepting a visual approach clearance automatically cancels the STAR procedure. A STAR may also be cancelled by ATC if required. If ATC cancels a STAR, the pilot should expect alternate instructions (either vectors to the final approach course, or a new route clearance). A STAR that has been cancelled may be reinstated by ATC.

9.2.3.18 Communication Failures on a Standard Terminal Arrival (STAR) Procedure

See the CFS, section F (Emergency), under Two-Way Communications Failure—IFR Flight Plan

9.3 Approach Clearance

When using direct controller pilot communications, ATC normally advises pilots of the ceiling, visibility, wind, runway, altimeter setting, approach aid in use, and pertinent aerodrome conditions (CRFI, RSC, etc.) immediately prior to or shortly after descent clearance. Upon acknowledging receipt of the current ATIS broadcast, the pilot is advised by ATC of the current airport conditions only if they are changing rapidly.

Aircraft destined to airports which underlie controlled low-level airspace and for which there is a published instrument approach procedure, will be cleared out of controlled airspace (vertically) via the published instrument approach procedure.

Example:

ATC CLEARS (aircraft identification) OUT OF CONTROLLED AIRSPACE VIA (name, type) APPROACH.

Aircraft destined to airports which underlie controlled low-level airspace and for which there is not a published instrument approach procedure will be cleared to descend out of controlled airspace and informed of the appropriate minimum IFR altitude.

Example:

ATC CLEARS (aircraft identification) TO DESCEND OUT OF CONTROLLED AIRSPACE VICINITY OF (aerodrome name). THE (minimum IFR altitude) IS (number) feet.

The pilot may elect to cancel IFR as soon as visual conditions permit the continuation of the flight under VFR, or remain on the IFR flight plan until the aircraft has landed and the pilot files an arrival report. Should the pilot anticipate that visual conditions to permit continued flight under VFR may not be achieved, the pilot may arrange with ATC to have the MEA protected.

Aircraft destined to airports which underlie controlled high-level airspace and where there is no minimum IFR altitude established that would prohibit such a manoeuvre will be cleared out of controlled high-level airspace.

Example:

ATC CLEARS (aircraft identification) OUT OF (type of airspace).

When an approach clearance is issued, the published name of the approach is used to designate the type of approach if adherence to a particular procedure is required. If visual reference to the ground is established before completion of a specified approach, the aircraft should continue with the entire procedure unless further clearance is obtained.

Example:

CLEARED TO THE OTTAWA AIRPORT, STRAIGHT-IN ILS RUNWAY ZERO SEVEN APPROACH.

CLEARED TO THE TORONTO AIRPORT, ILS RUNWAY ZERO SIX LEFT APPROACH.

The number of the runway on which the aircraft will land is included in the approach clearance when a landing will be made on a runway other than that aligned with the instrument approach aid being used.

Example:

CLEARED TO THE OTTAWA AIRPORT, STRAIGHT-IN ILS RUNWAY ZERO SEVEN APPROACH/CIRCLING PROCEDURE SOUTH FOR RUNWAY THREE TWO.

NOTE:

If the pilot begins a missed approach during a circling procedure, the published missed approach procedure as shown for the instrument approach just completed shall be flown. The pilot does not use the procedure for the runway on which the landing was planned.

At some locations during periods of light traffic, controllers may issue clearances that do not specify the type of approach.

Example:

CLEARED TO THE LETHBRIDGE AIRPORT FOR AN APPROACH.

When such a clearance is issued by ATC and accepted by the pilot, the pilot has the option of conducting any published instrument approach procedure. In addition, the pilot also has the option of proceeding by the route so cleared by ATC in a previous clearance, by any published transition or feeder route

associated with the selected procedure, or by a route present position direct to a fix associated with the selected instrument approach procedure. Pilots who choose to proceed to the instrument procedure fix via a route that is off an airway, air route or transition are responsible for maintaining the appropriate obstacle clearance, complying with noise abatement procedures and remaining clear of Class F airspace. As soon as practicable after receipt of this type of clearance, it is the pilot's responsibility to advise ATC of the type of published instrument approach procedure that will be carried out, the landing runway and the intended route to be flown.

This clearance does not constitute authority for the pilot to execute a contact or visual approach. Should the pilot prefer to conduct a visual approach (published or non-published) or a contact approach, the pilot must specifically communicate that request to the controller.

Upon changing to the tower or FSS frequency, pilots should advise the agency of the intended route and published instrument approach procedure being carried out.

The pilot should not deviate from the stated instrument approach procedure or route without the concurrence of ATC because such an act could cause dangerous conflict with another aircraft or a vehicle on a runway.

A clearance for an approach may not include any intermediate altitude restrictions. The pilot may receive this clearance while the aircraft is still a considerable distance from the airport, in either an ATS surveillance or non-ATS surveillance environment. In these cases, the pilot may descend, at his/her convenience, to whichever is the lowest of the following IFR altitudes applicable to the position of the aircraft:

- (a) minimum en route altitude (MEA);
- (b) published transition or feeder route altitude;
- (c) minimum sector altitude (MSA) specified on the appropriate instrument approach chart;
- (d) safe altitude 100 NM specified on the appropriate instrument approach chart; or
- (e) when in airspace for which the Minister has not specified a higher minimum, an altitude of at least 1 000 ft above the highest obstacle within a horizontal radius of 5 NM (1 500 ft or 2 000 ft within designated mountainous regions, depending on the zone) from the established position of the aircraft.

NOTE:

When a pilot receives and accepts an ATC clearance which authorizes descent to MSA or a safe altitude 100 NM during normal IFR operations, descent below the MEA for the preceding en route phase should not commence until the pilot can positively establish the aircraft's position by means of a bearing, radial, DME, ATS surveillance or visual means.

CAUTION:

Pilots are cautioned that descents to MSA or Safe Altitude 100 NM may, under certain conditions, exit controlled airspace. ATC provides IFR separation within controlled airspace only.

9.4 Descent Out of Controlled Airspace

ATC may not clear an aircraft to operate below the MEA of an airway, nor below the minimum IFR altitude in other controlled low-level airspace. The pilot, however, may operate at the MOCA, and ATC will approve flight at the MOCA at the pilot's request. If unable to cancel IFR at the MEA, the pilot may advise that he/she intends to descend to the MOCA. By prior arrangement with ATC, the MEA will be protected in the event that the pilot does not encounter visual conditions at the MOCA. Under this arrangement, the MEA will be protected:

- (a) until the pilot files an arrival report;
- (b) for 30 min; to allow descent to the MOCA and return to the MEA when communication is restored with ATC; or
- (c) if ATC does not hear from the pilot under (a) or (b), until the aircraft is estimated to have arrived at the filed alternate plus 30 min.

9.5 Advance Notice of Intent in Minimum Weather Conditions

ATC can handle missed approaches more efficiently if the controller knows the pilot's intentions in advance. They can use the extra time to plan for the possibility of a missed approach and thus provide better service in the event of an actual missed approach.

Pilots should adopt the following procedures as the occasion arises.

On receipt of approach clearance, when the ceiling and visibility reported at the destination airport is such that a missed approach is probable, the pilot should advise the controller as follows:

*IN THE EVENT OF MISSED APPROACH
REQUEST (altitude or level) VIA (route) TO (airport).*

Implementation of this procedure increases the amount of communications, but the increase can be minimized if pilots employ it only when there is a reasonable chance that a missed approach may occur.

9.6 Contact and Visual Approaches

9.6.1 Contact Approach

A contact approach is an approach wherein an aircraft on an IFR flight plan or flight itinerary having an ATC clearance, operating clear of clouds with at least 1 SM flight visibility and a reasonable expectation of continuing to the destination airport in those conditions, may deviate from the IAP and proceed to the destination airport by visual reference to the surface of the earth. Pilots are cautioned that conducting a contact approach in minimum visibility conditions introduces hazards to flight not experienced when flying IFR procedures. Familiarity with the aerodrome environment, including local area obstacles, terrain, noise sensitive areas, Class F airspace and aerodrome layout, is paramount for a successful contact approach in minimum visibility conditions. Pilots are responsible for the adherence to published noise abatement procedures and compliance with any restrictions that may apply to Class F airspace when conducting a contact approach.

NOTE:

This type of approach will only be authorized by ATC when:

- (a) the pilot requests it; and
- (b) there is an approved functioning instrument approach or a published GNSS approach for the airport.

An aircraft that requests a contact approach to an airport served only by a GNSS approach is indicating to ATIS that the pilot understands that no ground-based approach is available and is confirming that it is able to conduct a GNSS approach.

ATC will ensure IFR separation from other IFR flights and will issue specific missed approach instructions if there is any doubt that a landing will be accomplished. Pilots are cautioned that when any missed approach is initiated while conducting a contact approach, obstacle and terrain avoidance is the pilot's responsibility even though specific missed approach instructions may have been issued by ATC. ATC only ensures appropriate IFR separation from other IFR aircraft during contact approaches.

NOTE:

ATC will not issue an IFR approach clearance that includes clearance for a contact approach unless there is a published and functioning IAP or a restricted instrument approach procedure (RIAP) authorized by TC for the airport. Where a GNSS approach is the only available IAP or RIAP, this fulfills the requirement for a "functioning instrument approach."

9.6.2 Visual Approach

A visual approach is an approach wherein an aircraft on an IFR flight plan, operating in VMC under the control of ATC and having ATC authorization, may proceed to the destination airport. It permits aircraft to manage their lateral and vertical flight profiles according to the runway.

To gain operational advantages in a surveillance environment, the pilot may request a visual approach, or ATC may initiate one, provided that:

- (a) the reported ceiling at the destination airport is 500 ft or more above the minimum IFR altitude and the ground visibility is 3 statute miles or more;
- (b) at a controlled or uncontrolled airport, the pilot reports sighting the airport; and
- (c) at a controlled airport,
 - (i) the pilot reports sighting the preceding aircraft and is instructed by ATC to follow that aircraft; or
 - (ii) the pilot reports sighting the airport but not the preceding aircraft, in which case ATC will ensure separation from the preceding aircraft until:
 - (A) the preceding aircraft has landed; or
 - (B) the pilot has sighted the preceding aircraft and has been instructed to follow or maintain visual separation from it.

ATC considers acceptance of a visual approach clearance as acknowledgement that the pilot should be responsible for:

- (a) maintaining visual separation from the preceding aircraft that the pilot has been instructed to follow;
- (b) maintaining adequate wake turbulence separation from the preceding aircraft that the pilot has been instructed to follow;
- (c) navigating to the final approach course;
- (d) adhering to published noise abatement procedures and avoiding Class F airspace; and
- (e) at uncontrolled airports, maintaining appropriate separation from VFR traffic that, in many cases, will not be known to ATC.

ATC will issue a visual approach clearance and, as required, supplement it with additional instructions such as:

- (a) Heading assignment:
 - (i) To ensure the aircraft stays separated from preceding or succeeding traffic. ATC will consider the aircraft's altitude and remaining distance to the airport when using this method; and
 - (ii) To comply with parallel runway operation rules that require a 30-degree intercept heading to final prior to issuing the visual approach clearance.
- (b) Distance to intercept the final approach course and/or altitude to establish separation from traffic under the control tower's responsibility using references to:
 - (i) published NAVAIDs, fixes, or waypoints;
 - (ii) the distance from the runway; and
 - (iii) a prominent landmark on the final approach course.

ATC may anticipate that pilots will navigate to the final approach course using the following methods depending on the aircraft's altitude and distance from the airport:

- (a) Flying the shortest distance to the airport while complying with ATC and noise abatement restrictions; or
- (b) Using the on-board navigation guidance to follow a lateral profile reflecting any remaining portion of the STAR and the previously planned published instrument approach procedure. This provides the following benefits:
 - (i) enhanced aircraft energy management;
 - (ii) predictability;
 - (iii) reduced flight deck workload;
 - (iv) flexibility in meeting stabilized approach criteria; and
 - (v) adherence to altitude restrictions during nighttime conditions.

As both methods differ in terms of flying distance, it is good airmanship for pilots to advise ATC of the planned flight path, especially if it is likely to be unexpected or unpredictable, such as cases involving the widening of the base leg or the inability to shorten the flying distance as anticipated by ATC.

9.6.2.1 Missed Approach

A visual approach is not an IAP, and except for published visual approach procedures in the CAP, there are no procedures associated with a missed visual approach; visual approaches therefore have no missed approach segment. If a go-around is necessary for any reason, aircraft operating at controlled airports will be issued an appropriate advisory/clearance/instruction by the tower to ensure that separation from other airport traffic is maintained.

NOTE:

It is understood that the execution of a missed approach manoeuvre involves critical internal flight deck communications and high pilot workload. If these instructions are required for planning, pilots may request them before the approach clearance or at any time prior to initiating the missed approach.

ATC instructions will guide the pilot to:

1. continue flying the issued IFR clearance; or
 2. integrate into the airport VFR circuit.
- (a) Controlled Airports

At controlled airports, until missed approach instructions are issued, ATC should anticipate that pilots conducting a go-around from a visual approach will:

- (i) initially fly the runway heading;
- (ii) follow the published missed approach instructions for the IAP requested by the pilots and acknowledged by ATC; or
- (iii) follow the published missed approach instructions for the IAP advertised on the ATIS.

(b) Uncontrolled Airports

At uncontrolled airports, aircraft crews are required to remain clear of clouds and are expected to complete a landing as soon as possible. If a landing cannot be accomplished, the aircraft crew is required to:

- (i) remain clear of clouds; and
- (ii) maintain separation from other airport traffic.

The crew is also expected to contact ATC as soon as possible for further clearance.

ATC separation from other IFR aircraft is only assured once further ATC clearance has been received and acknowledged by the aircraft crew.

9.7 Arrivals

9.7.1 General

ATS surveillance separation is applied to arriving aircraft in order to establish and maintain the most desirable arrival sequence to avoid unnecessary “stacking”. In the approach phase, vectoring is carried out to establish the aircraft on an approach aid. The initial instruction is normally a turn to a heading for vectors to a final approach to the runway in use. Should a communications failure occur after this point, the pilot should

continue and carry out a straight-in approach if able, or carry out a procedure turn and land as soon as possible. Aircraft are vectored so as to intercept the final approach course approximately 2 NM from the point at which final descent will begin.

Example:

JULIETT WHISKEY CHARLIE, TURN LEFT HEADING ONE SEVEN ZERO TO INTERCEPT FINAL APPROACH COURSE. SEVEN MILES FROM AIRPORT. CLEARED FOR STRAIGHT-IN ILS RUNWAY ONE FIVE LEFT APPROACH. CONTACT TORONTO TOWER ON ONE ONE EIGHT DECIMAL SEVEN NOW.

9.7.2 ATS Surveillance Required

Traditionally, instrument approach procedures have been developed to include a procedure turn initial approach segment. Procedure turns permitted the pilot to “self navigate” the aircraft within the procedure in order to place the aircraft in a position to conduct a normal landing. Introducing DME and other feeder routes or transitions permitted the pilot to conduct a straight-in procedure without conducting the procedure turn. Most instrument procedures today are accomplished without conducting a procedure turn.

Instrument approaches at Canada’s major airports are conducted by vectors to the final approach course. While procedure turns are depicted on the instrument approach procedures at these airports, procedure turns are never flown. ATC route and space all aircraft within the terminal area in order to provide a systematic flow of the air traffic. An aircraft conducting a procedure turn manoeuvre at these major centres would cause serious traffic disruptions which may lead to losses of separation or possibly a mid-air collision.

Instrument procedures are being introduced eliminating the procedure turn as well as including a statement “ATS SURVEILLANCE REQUIRED” as part of the procedure. The initial approach segment of these instrument procedures is being provided by ATC vectors. Without ATC vectoring, the instrument procedure may not have a published initial approach segment.

Should an aircraft communication failure occur while being vectored for one of these approaches, refer to the communications failure procedures detailed in RAC Two-Way Communication Failure.

9.7.3 Speed Adjustment – ATS Surveillance-Controlled Aircraft

NOTE:

This section is for information only. It describes directives to controllers and in no way alters the applications of CAR 602.32, which prescribes the following maximum speeds for all aircraft:

1. below 10 000 ft ASL, 250 KIAS; and
2. below 3 000 ft AGL and within 10 NM of controlled airports, 200 KIAS.

To assist with vectoring, it is sometimes necessary to issue speed adjustments. While ATC will take every precaution not to request

speeds beyond the capability of the aircraft, it is the pilot's responsibility to ensure that the aircraft is not operated at an unsafe speed. If ATC issues a speed reduction that is inconsistent with safe operation, the pilot must inform ATC when unable to comply.

Speed adjustment will be expressed in units of 10 KIAS or multiples of 10 KIAS. Pilots complying with a speed adjustment are expected to maintain a speed within 10 KIAS of the specified speed.

Pilots may be asked to:

- (a) maintain present speed; or
- (b) increase or reduce speed to a specified speed or by a specified amount.

Unless prior concurrence in the use of a lower speed is obtained from the pilot, the following minimum speeds will be applied to:

- (a) aircraft operating 20 NM or more from destination airport:
 - (i) at or above 10 000 ft ASL: 250 KIAS; and
 - (ii) below 10 000 ft ASL: 210 KIAS;
- (b) turbojet aircraft operating less than 20 NM from destination airport: 160 KIAS; and
- (c) propeller-driven aircraft operating less than 20 NM from destination airport: 120 KIAS.

Pilots of aircraft that cannot attain speeds as high as the minimum speeds specified may be requested to:

- (a) maintain a specified speed equivalent to that of a preceding or succeeding aircraft; or
- (b) increase or decrease speed by a specified amount.

The issuance of an approach clearance normally cancels a speed adjustment; however, if the controller requires that a pilot maintain a speed adjustment after the issuance of the approach clearance, the controller will restate it. Otherwise, ATC may use the phrase "resume normal speed" to advise a pilot that previously issued speed restrictions are cancelled. Unless specifically stated by ATC, an instruction to "resume normal speed" does not cancel speed restrictions that are applicable to published procedures of upcoming segments of flight.

9.7.4 Precision Radar Approaches

Precision Radar Approaches (PARs) are provided at aerodromes with military PAR units. The aircraft is vectored by surveillance radar to a predetermined position, at which point control is transferred to the PAR controller for the approach.

Example:

JULIETT WHISKEY CHARLIE, EIGHT MILES FROM AIRPORT, TURN LEFT HEADING TWO SEVEN ZERO FOR FINAL APPROACH. CLEARED FOR PRECISION RADAR APPROACH RUNWAY TWO FOUR. CONTACT TRENTON PRECISION ON ONE TWO EIGHT DECIMAL SEVEN NOW.

In an emergency, where surveillance radar coverage permits it, air traffic controllers will provide a surveillance radar approach if no alternative method of approach is available and the pilot declares an emergency and requests a radar approach.

NOTE:

NAV CANADA are not flight-checked or commissioned for surveillance approaches, nor are NAV CANADA controllers specifically trained to provide them.

9.8 Initial Contact with Control Towers

Pilots should establish contact with the control tower as follows:

- (a) If in direct communication with an ACC or a TCU, the IFR controller shall advise the pilot when contact is to be made with the tower. Unless on vectors to final approach, pilots should give the tower their ETA to the facility for the approach they intend to fly.
- (b) If the conditions above do not apply, pilots should establish communication with the tower when approximately 25 NM from the airport, give their ETA, obtain an ATC approach clearance (if not already received), advise approach intentions and remain on tower frequency.

NOTE:

Whenever an ETA is passed, the pilot should specify the point, fix or facility to which the ETA applies.

9.9 Approach Position Reports—Controlled Airports

Pilots conducting an instrument approach to, or landing at, a controlled airport should only make position reports that are requested by the appropriate ATC unit. As an example, pilots may expect ATC to request a report by the Final Approach Fix (FAF) or a specified distance on final. Position reports made under these circumstances are expected to be stated by reporting the position only.

9.10 Control Transfer—Instrument Flight Rules (IFR) Units to Towers

Tower controllers may accept responsibility for control of an arriving IFR flight within the CZ if VMC exist at an airport, and the aircraft has been sighted and will remain in sight. The transfer of control to the tower does not cancel the IFR flight plan, but rather indicates that the aircraft is now receiving airport control service. In such instances, IFR separation minima may not continue to be applied. The tower controller may use visual separation procedures, or issue clearances and instructions as necessary to maintain a safe, orderly and expeditious flow of airport traffic. Occasionally the tower controller may issue instructions that supersede previous instructions and clearances that the pilot had received from the IFR unit. Acknowledgement of these instructions indicates to the tower that the pilot shall comply with them. A pilot must not assume that the control tower has ATS surveillance equipment or that ATS surveillance service is being provided.

9.11 Initial Contact with Air-Ground Facility at Uncontrolled Aerodromes

Pilots shall establish communications with the air-ground facility (FSS, RCO, CARS or UNICOM) on the appropriate frequency if in direct communication with an ACC or a TCU, when directed to do so by the ACC or TCU.

Notwithstanding this, in accordance with CAR 602.104, pilots shall establish communication with the facility on the appropriate frequency no later than five minutes prior to the estimated time of commencing the approach procedure. If the ATC approach clearance has not already been received, it should be obtained from the agency listed on CAP approach charts, unless otherwise directed by ATC.

NOTES:

1. If a pilot is instructed to remain on the ATC frequency rather than being transferred to the appropriate frequency for the uncontrolled aerodrome, it remains the pilot's responsibility to notify the associated destination aerodrome ground station, or to broadcast where no ground station exists, and report in accordance with the following subsection. This may be accomplished by taking one of the following actions:
 - (a) if the aircraft is equipped with more than one two-way communication radio, the pilot is expected to make the report on the appropriate frequency with the secondary radio, while monitoring the ATC frequency on the primary radio; or
 - (b) if the aircraft is equipped with a single two-way communication radio, the pilot must first request and receive permission to leave the ATC frequency in order to transmit this directed or broadcast report and then return to the ATC frequency; or, if this is not possible, the pilot should specifically request ATC to notify the associated ground station of their approach intentions and estimated time of landing.
2. At aerodromes where RAAS is provided via an RCO and where AWOS (or LWIS) weather information is also broadcast via a voice generator module (VGM), it is recommended that pilots listen to the broadcast prior to contacting the air-ground facility, and upon contact, advise that they have the wind and altimeter information.

Because a VGM weather broadcast contains up-to-the-minute weather, it will be more current and may differ slightly from the most recently disseminated aerodrome routine meteorological report (METAR) or aviation selected special weather report (SPECI). The latest METAR or SPECI for the remote aerodrome will be provided, upon request, from the ATS unit controlling the RCO.

9.12 Instrument Flight Rules (IFR) Reporting Procedures at Uncontrolled Aerodromes

Subsection 1 of CAR 602.104—Reporting Procedures for IFR Aircraft When Approaching or Landing at an Uncontrolled Aerodrome “applies to persons operating IFR aircraft when approaching or landing at an uncontrolled aerodrome, whether or not the aerodrome lies within an MF area.”

Subsection 2 of CAR 602.104 states:

The pilot-in-command of an IFR aircraft who intends to conduct an approach to or a landing at an uncontrolled aerodrome shall report

- (a) the pilot-in-command's intentions regarding the operation of the aircraft
 - (i) five minutes before the estimated time of commencing the approach procedure, stating the estimated time of landing,
 - (ii) when commencing a circling manoeuvre, and
 - (iii) as soon as practicable after initiating a missed approach procedure; and
- (b) the aircraft's position
 - (i) when passing the fix outbound, where the pilot-in-command intends to conduct a procedure turn or, if no procedure turn is intended, when the aircraft first intercepts the final approach course,
 - (ii) when passing the final approach fix or three minutes before the estimated time of landing where no final approach fix exists, and
 - (iii) on final approach.

In addition to these requirements, pilots operating aircraft under IFR into an uncontrolled aerodrome, when the weather conditions at the aerodrome could permit VFR circuit operations, are expected to approach and land on the active runway that may be established by the aircraft operating in the VFR circuit. Pilots operating aircraft under IFR at an uncontrolled aerodrome do not establish any priority over aircraft operating under VFR at that aerodrome. Should it be necessary for the IFR aircraft to approach and/or land on a runway contrary to the established VFR operation, it is expected that appropriate communications, between pilots or between pilots and the air-ground facility, will be effected in order to ensure there is no traffic conflict.

9.13 Instruments Flight Rules (IFR) Procedures at an Uncontrolled Aerodrome in Uncontrolled Airspace

Pilots operating under IFR in uncontrolled airspace should, whenever practical, monitor 126.7 MHz and broadcast their intentions on this frequency immediately prior to changing altitude or commencing an approach. Therefore, when arriving at an aerodrome where another frequency is designated as the MF, descent and approach intentions should be broadcast on 126.7 MHz before changing to the MF. If conflicting IFR traffic becomes evident, this change should be delayed until the conflict is resolved. Once established on the MF, the pilot shall make the reports listed in the subsection above.

A straight-in landing from an IFR approach should not be used at an uncontrolled aerodrome where air-ground advisory is not available to provide the wind direction and speed and runway condition reports required to conduct a safe landing. The pilot should determine the wind and verify that the runway is unobstructed before landing. Where pilots lack any necessary information, they are expected to ensure that a visual inspection of the runway is completed prior to landing. In some cases, this can only be accomplished by conducting a circling approach using the appropriate circling MDA.

Pilots operating aircraft under IFR into an uncontrolled aerodrome in uncontrolled airspace when the weather conditions at the aerodrome could permit VFR circuit operations are expected to approach and land on the active runway that may be established by the aircraft operating in the VFR circuit. Pilots operating aircraft under IFR at an uncontrolled aerodrome in uncontrolled airspace do not establish any priority over aircraft operating under VFR at that aerodrome. Should it be necessary for the IFR aircraft to approach to, land, or take off on a runway contrary to the established VFR operation, it is expected that appropriate communications between the pilots, or pilots and the air-ground facility, will be effected in order to ensure that there is no conflict of traffic.

9.14 Outbound Report

To apply the prescribed separation minima between aircraft intending to make a complete instrument approach procedure and other aircraft, ATC must often establish the position and direction of arriving aircraft with respect to the approach facility. When reporting “outbound”, pilots should make these reports only after they are over or abeam the approach facility and proceeding in a direction away from the airport.

9.15 Straight-In Approach

ATC uses the term “straight-in approach” to indicate an instrument approach conducted so as to position the aircraft on final approach without performing a procedure turn.

9.16 Straight-In Approaches from an Intermediate Fix

Published transitions normally are designated from an en route navigation aid to the primary approach aid upon which the procedure turn is based. However, to accommodate aircraft with modern avionics equipment and to improve fuel economy, transitions at some locations direct the pilot to an intermediate fix (IF) on the final approach course. Subject to ATC requirements and local traffic conditions, a straight-in approach may be made from this fix.

Intermediate fixes are usually located on the final approach track at the procedure turn distance specified in the profile view. This distance, which is normally 10 NM, is the distance within which the procedure turn should be executed. Accordingly, after passing the fix and manoeuvring the aircraft onto the proper inbound track, descent may be made to the appropriate published altitude that would apply as if a procedure turn had been completed.

The abbreviation “NO PT” is used to denote that no procedure turn is necessary from the point indicated and will normally be shown adjacent to the IF. However, if the minimum altitude IF to the final approach fix (FAF) is not readily apparent, the “NO PT” abbreviation may be shown at some point between the fix and FAF, along with an altitude applicable for this segment.

Where more than one transition intersects the final approach track at different points, only the furthest intersection is designated as the IF. Pilots may begin a straight-in approach from any depicted transition that intersects the final approach track inside the designated IF provided that ATC is aware of their intentions and subsequent manoeuvring is within the capabilities of the aircraft.

If the aircraft is badly positioned, laterally or vertically, after being cleared by ATC for the straight-in approach, pilots should climb to the procedure turn altitude, or the minimum altitude at the facility if one is depicted, and proceed to the FAF requesting clearance for a procedure turn.

NOTE:

If the FAF is behind the aircraft, the pilot must conduct a missed approach and request further clearance from ATC.

The depiction of radials on a DME arc transition to an IF are normally limited to the radial forming the IAF at the beginning of the arc, the lead radial (if required) to indicate where the turn to the final approach track should be commenced, and radials forming step-down fixes if descent to lower altitudes can be approved. However, the arc may be joined from any radial that intercepts the depicted arc.

9.17 Procedure Altitudes and Current Altimeter Setting

All altitudes published in the CAP are minimum altitudes that meet obstacle clearance requirements when International Standard Atmosphere (ISA) conditions exist and the aircraft altimeter is set to the current altimeter setting for that aerodrome. The altimeter setting may be a local or a remote setting when so authorized on the instrument approach chart. A current altimeter setting is one provided by approved direct reading or remote equipment or by the most recent routine hourly weather report. These readings are considered current up to 90 min from the time of observation. Care should be exercised when using altimeter settings older than 60 min or when pressure has been reported as falling rapidly. In these instances, a value may be added to the published DH/MDA in order to compensate for falling pressure tendency (0.01 inches of mercury = 10-ft correction). When an authorized remote altimeter setting is used, the altitude correction shall be applied as indicated.

9.17.1 Corrections for Temperature

Pressure altimeters are calibrated to indicate true altitude under ISA conditions. Any deviation from ISA will result in an erroneous reading on the altimeter. In a case when the temperature is higher than the ISA, the true altitude will be higher than the figure indicated by the altimeter, and the true altitude will be lower when the temperature is lower than the ISA. The altimeter error may be significant, and becomes extremely important when considering obstacle clearances in cold temperatures.

The published minimum IFR altitudes (i.e. the MSA/TAA and the initial/intermediate/final and missed approach segments, including the MDA/DA) must be adjusted when the ambient temperature on the surface is much lower than that predicted by the standard atmosphere. As a general rule this is considered to be 0°C or, when MDAs/DAs are 1 000 ft HAA or higher, it begins at 10°C.

NOTE:

Should the pilot feel that the above rules do not adequately adjust the published minimum IFR altitudes in the procedures to compensate for low temperatures, it is at the pilot's discretion to apply temperature correction whenever the aerodrome temperature is below the ISA.

Corrections may be obtained from the “Altitude Correction Chart” in the CAP (which is reproduced as Table 9.1 in RAC). This chart is calculated for an aerodrome at sea level. It is, therefore, conservative when applied to aerodromes at higher altitudes. To calculate the corrections (reduced altitudes) for specific aerodromes or altimeter setting sources above sea level, or for values not tabulated, refer to the following paragraphs.

With respect to altitude corrections, the following procedures apply:

- (a) IFR assigned altitudes may be either accepted or refused. Refusal in this case is based upon the pilot's assessment of temperature effect on obstacle clearance. IFR assigned altitudes accepted by a pilot should not be adjusted to compensate for cold temperatures, i.e. if a pilot accepts “maintain 3 000”, an altitude correction should not be applied to 3 000 ft.
- (b) Vectoring altitudes assigned by ATC are temperature corrected and require no temperature compensation by pilots.
- (c) When altitude corrections are applied to a published mandatory altitude or missed approach holding altitude, pilots should advise ATC of the temperature-corrected altitude prior to crossing the associated waypoint.

The “Altitude Correction Chart” was calculated assuming a linear variation of temperature with height. It is based on the following equation, which may be used with the appropriate value of t_o , H , L_o and H_{ss} to calculate temperature corrections for specific conditions. This equation produces results that are within five percent of the accurate correction for altimeter setting sources up to 10 000 ft and with minimum heights up to 5 000 ft above that source. Unless otherwise specified, the destination aerodrome elevation is used as the elevation of the altimeter source.

Table 9.1—Altitude Corrections Based on Aerodrome Cold Temperatures

Aerodrome Temperature °C	Height above the elevation of the altimeter setting sources (feet)													
	200	300	400	500	600	700	800	900	1 000	1 500	2 000	3 000	4 000	5 000
+10									20	30	40	60	80	100
0	20	20	30	30	40	40	50	50	60	90	120	170	230	290
-10	20	30	40	50	60	70	80	90	100	150	200	290	390	490
-20	30	50	60	70	90	100	120	130	140	210	280	430	570	710
-30	40	60	80	100	120	130	150	170	190	280	380	570	760	950
-40	50	80	100	120	150	170	190	220	240	360	480	720	970	1 210
-50	60	90	120	150	180	210	240	270	300	450	600	890	1 190	1 500

NOTES:

1. The corrections have been rounded up to the next 10-ft increment.
2. Values must be added to published minimum IFR altitudes.
3. Temperature values from the reporting station nearest to the position of the aircraft should be used. This is normally the aerodrome.

Table 9.2—Example of Corrections for an Aerodrome at an Elevation of 2 262 ft with a Temperature of -50°C

—	ALTITUDE	HAA	CORRECTION	INDICATED ALTITUDE
Procedure Turn	4 000 ft	1 738 ft	+521.4 ft ¹	4 600 ft ²
FAF	3 300 ft	1 038 ft	+311.4 ft	3 700 ft
MDA Straight-in	2 840 ft	578 ft	+173.4 ft	3 020 ft
Circling MDA	2 840 ft	578 ft	+173.4 ft	3 020 ft

¹ CORRECTION derived as follows:
 (2 000 ft at -50° error) 600 – (1 500 ft at -50° error) 450 = 150
 Altitude difference of above (2 000 – 1 500) = 500
 Error per foot difference (150/500) = 0.3 HAA = 1 738
 Error at 1 738 = (1 738 – 1 500) * 0.3 = 71.4 + 450 (error -50° at 1 500) = 521.4

² INDICATED ALTITUDE derived as follows:
 Calculated error at 1 738 from above = 521.4
 Procedure-turn altitude (4 000) + error (521.4) = 4 521.4
 INDICATED ALTITUDE rounded next higher 100-ft increment = 4 600

Figure 9.14—Correction for Cold Temperatures: Equation

$$\text{Correction} = H \times \left(\frac{15 - t_0}{273 + t_0 - 0.5 \times L_0 \times (H + H_{ss})} \right)$$

where:

H = minimum height above the altimeter setting source
(setting source is normally the aerodrome unless otherwise specified)

t_0 = $t_{\text{aerodrome}} + L_0 \times h_{\text{aerodrome}}$ aerodrome (or specified temperature reporting point) temperature adjusted to sea level

L_0 = 0.0065°C per metre or 0.00198°C per foot

H_{ss} = altimeter setting source elevation

$t_{\text{aerodrome}}$ = aerodrome (or specified temperature reporting point) temperature

$h_{\text{aerodrome}}$ = aerodrome (or specified temperature reporting point) elevation

The actual lapse rate may vary considerably from the assumed standard, depending on latitude and time of year. However, the corrections derived from the linear approximation can be taken as a satisfactory estimate for general application at levels up to 10 000 ft.

9.17.2 Remote Altimeter Setting

Normally, approaches shall be flown using the current altimeter setting only for the destination aerodrome. However, at certain aerodromes where a local pressure setting is not available, approaches may be flown using a current altimeter setting for a nearby aerodrome. Such an altimeter setting is considered a remote altimeter setting, and authorization for its use is published in the RASS box, located at the bottom left-hand corner of the approach chart, adjacent to the minima box, below the profile view.

If the use of a remote altimeter setting is required for limited hours only, an altitude correction will be included with the authorization. When the remote altimeter setting is used, the altitude correction shall be applied as indicated. If the use of a remote altimeter setting is required at all times, then the correction is incorporated into the procedure at the time it is developed.

Examples:

1. RASS: When using CYYY add 200’.

(When using the Mont-Joli altimeter setting, add 200 ft to the intermediate, final and missed approach segment minimum altitudes.)

2. RASS: Use CYXU.

(Use London altimeter setting.)

If the altitude correction results in the calculated rate of descent exceeding design parameters, the words “circling minima apply” will be added to the RASS box. The intent of this note is to draw the pilot’s attention to the fact that he/she cannot use straight-in minima when using the remote altimeter source. However, this does not prohibit the pilot from landing straight in if he/she has adequate visual reference in applying circling minima and the aircraft is suitably positioned to land straight in.

Example:

RASS: When using CYHU add 120’. Circling minima apply.

(When using St-Hubert altimeter, add 120 ft to the intermediate, final and missed approach segment minimum altitudes; circling minima apply.)

9.18 Departure, Approach and Alternate Minima

The civil minima published in the CAP shall, unless otherwise authorized, be observed by all pilots in accordance with their instrument rating. Authorization to operate to special limits may be obtained by air operators in accordance with Part VII of the CARs or by private operators in accordance with subpart 604 of the CARs

9.18.1 Category II Instrument Landing System (ILS) Approach Minima

Category II operations are precision approaches in weather minima as low as 100 ft DH and RVR 1 200 ft. These minima are restricted to aircraft and pilots specifically approved for such operations by TC and to runways specially equipped for the category of operation. Details on Category II requirements are contained in CAR 602.128, *Landing Minima, and the Manual of All Weather Operations (Categories II and III)* (TP 1490E).

Table 9.3—Instrument Rating Weather Minima for CAT II ILS Approach

	AIRCRAFT	ROTORCRAFT
TAKEOFF VISIBILITY	CAP	1/2 CAP but not less than 1/4 SM.
LANDING DH or MDA	CAP	CAP
ALTERNATE WEATHER MINIMA REQUIREMENTS – CAP GEN		
FACILITIES AVAILABLE AT SUITABLE ALTERNATE	WEATHER REQUIREMENTS	
TWO OR MORE USABLE PRECISION APPROACHES Each providing straight-in minima to separate suitable runways.	400 - 1 or 200 - 1/2 above the lowest usable HAT and visibility, whichever is greater.	N/A
ONE USABLE PRECISION APPROACH	600 - 2* or 300-1 above the lowest usable HAT and visibility, whichever is greater.	N/A
NON-PRECISION ONLY AVAILABLE	800 - 2* or 300-1 above the lowest usable HAT/HAA and visibility, whichever is greater.	N/A
NO IFR APPROACH AVAILABLE	Forecast weather must be no lower than 500 ft above a minimum IFR altitude that will permit a VFR approach and landing.	N/A
FOR ROTORCRAFT Where instrument approach procedures are available.	N/A	Ceiling 200 ft above the minima for the approach to be flown, and visibility at least 1 SM but never less than the minimum visibility for the approach to be flown.

9.19 Application of Minima

9.19.1 Takeoff Minima

CAR 701.20—Take-off Minima states that:

For the purposes of section 602.126, a person may conduct a take-off in an aircraft where weather conditions are below the take-off minima specified in the *Canada Air Pilot* if:

- (a) in the case of a foreign air operator, the foreign air operator is authorized to do so in its Canadian foreign air operator certificate and complies with the Commercial Air Service Standards; or
- (b) in the case of a person who operates a foreign state aircraft, the person is authorized to do so in a flight authorization and complies with the Commercial Air Service Standards.

Subsection (1) of CAR 602.126—Take-off Minima states that:

No pilot-in-command of an aircraft shall conduct a take-off if the take-off visibility, as determined in accordance with subsection (2), is below the minimum take-off visibility specified in:

- (a) the air operator certificate where the aircraft is operated in accordance with Part VII;
- (b) a special authorization issued under subsection 604.05(2); or
- (c) the *Canada Air Pilot* in any case other than a case described in paragraph (a) or (b).

Subsection (2) of CAR 602.126 states that:

For the purposes of subsection (1), the take-off visibility is:

- (a) the RVR of the runway, if the RVR is reported to be at or above the minimum take-off visibility specified in a document or the manual referred to in subsection (1);
- (b) the ground visibility of the aerodrome for the runway, if the RVR
 - (i) is reported to be less than the minimum take-off visibility specified in a document or the manual referred to in subsection (1),
 - (ii) is reported to vary between distances less than and greater than the minimum take-off visibility specified in the *Canada Air Pilot* or a certificate referred to in subsection (1), or
 - (iii) is not reported; or
- (c) the runway visibility as observed by the pilot-in-command, if
 - (i) the RVR is not reported, and
 - (ii) the ground visibility of the aerodrome is not reported.
 - (iii) With respect to takeoff visibility, pilots will be advised of the ground visibility by the appropriate ATS unit. In the following example, explanations are provided to illustrate whether takeoff is authorized in a variety of visibility conditions.

Examples:

A takeoff is to be conducted from Runway 27; the pilot is authorized a takeoff minimum of RVR 2600 (1/2 SM).

1. ATC/FSS reports "... RVR Runway 27 is 2000, variable 1600-2800, visibility 1/2 mile".

Although the RVR variation may be below minimum, a takeoff is authorized because the reported ground visibility of 1/2 mi. is governing.

2. ATC/FSS reports "... RVR Runway 27 is 2200, visibility observed on-the-hour 1/4 mile, visibility now 1/2 mile".

Although the RVR is below minimum, a takeoff is authorized because the reported ground visibility of 1/2 mi. is governing.

3. ATC/FSS reports "... RVR 2600, visibility 1/4 mile".

A takeoff is authorized since the lowest reported RVR is at or above minimum.

4. ATC/FSS reports "... RVR Runway 27 is 2000, variable 1600-2800, visibility 1/4 mile".

A takeoff is not authorized since both the lowest RVR and the reported ground visibility are below minimum.

5. ATC/FSS reports "... RVR Runway 27 is 2000 ...".

A takeoff is not authorized because the reported RVR is below minimum.

6. ATC/FSS/CARS reports only "... visibility observed on-the-hour 1/4 mile".

A takeoff is not authorized because reported visibility is below minimum.

In summary, a takeoff is authorized when:

- (a) the lowest reported RVR for the runway is at or above the minimum takeoff visibility, regardless of reported ground visibility;
- (b) the reported ground visibility for the aerodrome is at or above the minimum takeoff visibility, regardless of the reported RVR for the runway; or
- (c) in the absence of a reported RVR or reported ground visibility, the runway visibility as observed by the pilot in command is at or above minimum takeoff visibility.

9.19.2 Approach Ban

9.19.2.1 General Aviation—Non-Precision Approach (NPA), Approach Procedure with Vertical Guidance (APV), CAT I or CAT II Precision Approach

CAR 602.129 specifies that instrument approaches by general aviation aircraft are governed by RVR values only. With certain exceptions, pilots of aircraft are prohibited from completing an instrument approach past the FAF (or where there is no FAF, the point where the final approach course is intercepted) to a runway served by an RVR, if the RVR values as measured for that runway are below the following minima:

Table 9.4—Minimum RVR for Airplanes and Helicopters (General Aviation)

MEASURED RVR*	AEROPLANES	HELICOPTERS
RVR "A" only	1 200	1 200
RVR "A" and "B"	1 200/600	1 200/0
RVR "B" only	1 200	1 200

* RVR "A" located adjacent to the runway threshold.
RVR "B" located adjacent to the runway mid-point.

The following exceptions to the above prohibitions apply to all aircraft when:

- (a) the below-minima RVR report is received, the aircraft is inbound on approach and has passed the FAF, or where there is no FAF, the point where the final approach course is intercepted;
- (b) the pilot-in-command has informed the appropriate ATC unit that the aircraft is on a training flight and that the pilot-in-command intends to initiate a missed approach procedure at or above the DH or the MDA, as appropriate;
- (c) the RVR is varying between distances less than and greater than the minimum RVR;
- (d) the RVR is less than the minimum RVR, and the ground visibility at the aerodrome where the runway is located is reported to be at least one-quarter statute mile; or
- (e) the pilot-in-command is conducting a precision approach to CAT III minima.

With respect to approach restrictions, in the case of a localized phenomenon or any fluctuations that affect RVR validity, where the ground visibility is reported by ATC or FSS to be at or above one-quarter statute mile, an approach may be completed.

Example:

An ILS approach is to be conducted to Runway 27; RVR sensors are located at positions A and B; the pilot is flying an aeroplane.

1. ATC/FSS reports "... RVR "A" 800, RVR "B" 800, observed visibility one-quarter statute mile."

An approach to DH/MDA is authorized because the reported ground visibility of one-quarter statute mile is governing.

2. ATC/FSS reports "... RVR "A" not available, RVR "B" 1 000."

An approach to DH/MDA is not authorized since RVR "B" is governing and is below 1 200 ft.

If, after commencing an approach (but before reaching the FAF, or where there is no FAF, the point where the final approach course is intercepted), a pilot must discontinue an approach because the RVR has gone below minima, the pilot shall continue as cleared, advise ATC of their intentions and request further clearance. If further clearance is not received by the time the aircraft reaches the FAF, or where there is no FAF, the point where the final approach course is intercepted, the pilot shall execute a missed approach and proceed via the missed approach procedure to the specified missed approach clearance limit.

In summary, an approach is authorized whenever:

- (a) the lowest reported RVR for the runway is at or above minima (CAR 602.129), regardless of reported ground visibility;
- (b) the RVR is reported to be varying between distances less than and greater than the minimum RVR;
- (c) the RVR is below the minimum, and the ground visibility is reported to be at least one-quarter statute mile;
- (d) the RVR for the runway is unavailable or not reported; or
- (e) ATIS is informed that an aircraft is on a training flight and will conduct a planned missed approach.

No pilot shall commence an NPA, an APV, or a CAT I or CAT II precision approach to an airport where low-visibility procedures are in effect. Low-visibility procedures are associated with CAT III operations. They are specified for an airport (for example, CYVR or CYYZ) in the CAP and restrict aircraft and vehicle operations on the movement area of the airport when the RVR is less than 1 200 ft.

9.19.2.2 Approach Ban—General Aviation—CAT III Precision Approach

CAR 602.130 specifies the general aviation CAT III precision approach ban. No pilot shall continue a CAT III precision approach in an IFR aircraft beyond the FAF inbound, or where there is no FAF, the point where the final approach course is intercepted, unless the RVR reported is equal to or greater than the minimum RVR specified in the CAP in respect of the runway or surface of intended approach for the IAP conducted.

Table 9.5—Minimum RVR for Aircraft CAT III Approaches (General Aviation)

MEASURED RVR*	CAT IIIA	CAT IIIB	CAT IIIC
RVR “A”, “B” and “C”	600/600/600	Not Authorized	Not Authorized

*RVR “A” located adjacent to the runway threshold.
 RVR “B” located adjacent to the runway mid-point.
 RVR “C” located adjacent to the runway end.

9.19.2.3 Approach Ban—Commercial Operators—General—Non-Precision Approach (NPA), Approach Procedure with Vertical Guidance (APV), or CAT I Precision Approach

CAR 700.10 specifies the NPA, APV and precision approach ban that generally applies to commercial operators. With certain exceptions, pilots of commercial aircraft are prohibited from completing an NPA, an APV, or a CAT I precision approach past the FAF inbound, or where there is no FAF, the point where the final approach course is intercepted, if the visibility report is below the value corresponding to the CAP advisory visibility for the approach conducted.

Table 9.6—Minimum Visibility for Airplanes (Commercial Operators)

CAP ADVISORY VISIBILITY (SM, RVR x 100 ft)	VISIBILITY REPORT (Grnd Vis SM, RVR “A” or Rwy Vis ft)
1/2 RVR 26	3/8, RVR or Rwy Vis 1 600
3/4 RVR 40	5/8, RVR or Rwy Vis 3 000
1 RVR 50	3/4, RVR or Rwy Vis 4 000
1 1/4	1, RVR or Rwy Vis 5 000
1 1/2	1 1/4, RVR or Rwy Vis 6 000
1 3/4	1 1/2, RVR or Rwy Vis > 6 000
2	1 1/2, RVR or Rwy Vis > 6 000
2 1/4	1 3/4, RVR or Rwy Vis > 6 000
2 1/2	2, RVR or Rwy Vis > 6 000
2 3/4	2 1/4, RVR or Rwy Vis > 6 000
3	2 1/4, RVR or Rwy Vis > 6 000

Table 9.7—Minimum Visibility for Helicopters (Commercial Operators)

MEASURED RVR	HELICOPTERS
RVR “A” only	1 200
RVR “A” and “B”	1 200/0
RVR “B” only	1 200

An RVR report takes precedence over a runway visibility report or a ground visibility report, and a runway visibility report takes precedence over a ground visibility report. Ground visibility will only impose an approach ban at aerodromes south of 60°N latitude. If no RVR, runway visibility, or ground visibility is reported, there are no criteria to impose an approach ban. (This concept is similar to the present CAR 602 approach ban, where if there is no RVR reported, there is no criterion to impose an approach ban.)

The following exceptions to the above prohibitions apply to all aircraft when:

- (a) the visibility report is below the required value, and the aircraft has passed the FAF inbound, or where there is no FAF, the point where the final approach course is intercepted;
- (b) the pilot-in-command has informed the appropriate ATC unit that the aircraft is on a training flight and that the pilot-in-command intends to initiate a missed approach



procedure at or above the decision altitude (height) [DA(H)] or the MDA, as appropriate;

- (c) the RVR is varying between distances less than and greater than the minimum RVR;
- (d) the ground visibility is varying between distances less than and greater than the minimum visibility;
- (e) a localized meteorological phenomenon is affecting the ground visibility to the extent that the visibility on the approach to the runway of intended approach and along that runway, as observed by the pilot in flight and reported immediately to ATS, if available, is equal to or greater than the visibility specified in the CAP for the IAP conducted; or
- (f) the approach is conducted in accordance with an Operations Specification issued in accordance with CAR 703, 704 or 705.

No pilot shall commence an NPA, an APV, or a CAT I precision approach to an airport where low-visibility procedures are in effect. Low-visibility procedures are associated with CAT III operations. They are specified for an airport (for example, CYVR or CYYZ) in the CAP and restrict aircraft and vehicle operations on the movement area of the airport when the RVR is less than 1 200 ft.

9.19.2.4 Approach Ban—Commercial Operators—CAT II and CAT III Precision Approach

CAR 700.11 specifies the CAT II and CAT III precision approach ban that applies to commercial operators. No pilot shall continue a CAT II or CAT III precision approach in an IFR aircraft beyond the FAF inbound, or where there is no FAF, the point where the final approach course is intercepted, unless the RVR reported is equal to or greater than the minimum RVR specified in the CAP in respect of the runway or surface of intended approach for the IAP conducted.

Table 9.8— Minimum RVR for Airplane and Helicopter CAT II Approaches (Commercial Operators)

MEASURED RVR*	AEROPLANES	HELICOPTERS
RVR “A” and “B”	1 200/600	1 200/0

Table 9.9— Minimum RVR for Aircraft CAT III Approaches (Commercial Operators)

MEASURED RVR *	CAT IIIA	CAT IIIB	CAT IIIC
RVR “A”, “B” and “C”	600/600/600	Not Authorized	Not Authorized

*RVR “A” located adjacent to the runway threshold.
 RVR “B” located adjacent to the runway mid-point.
 RVR “C” located adjacent to the runway end.

9.19.2.5 Approach Ban—Commercial Operators—Operations Specification—Non-Precision Approach (NPA), Approach Procedure with Vertical Guidance (APV), or CAT I Precision Approach

CARs 703.41, 704.37, and 705.48 specify the NPA, APV and precision approach ban that applies to commercial operators through an Operations Specification. CAR 703, 704 and 705 operators authorized through Operations Specification 019, 303 or 503 and who meet all the conditions related to the approach procedure, are permitted to conduct an approach at a visibility value less than those specified in the CAR 700 approach ban. With certain exceptions, pilots of commercial aircraft are prohibited from completing an NPA, an APV, or a CAT I precision approach past the FAF inbound, or where there is no FAF, the point where the final approach course is intercepted, if the visibility report is below the value corresponding to the CAP advisory visibility for the approach conducted.

Table 9.10— Minimum Visibility for Airplanes (CARs 703/704/705 Operations)

CAP ADVISORY VISIBILITY (SM, RVR x 100 ft)	VISIBILITY REPORT (Grnd Vis SM, RVR “A” or Rwy Vis ft)
1/2 RVR 26	1/4, RVR or Rwy Vis 1 200
3/4 RVR 40	3/8, RVR or Rwy Vis 2 000
1 RVR 50	1/2, RVR or Rwy Vis 2 600
1 1/4	5/8, RVR or Rwy Vis 3 400
1 1/2	3/4, RVR or Rwy Vis 4 000
1 3/4	1, RVR or Rwy Vis 5 000
2	1, RVR or Rwy Vis 5 000
2 1/4	1 1/4, RVR or Rwy Vis 6 000
2 1/2	1 1/4, RVR or Rwy Vis > 6 000
2 3/4	1 1/2, RVR or Rwy Vis > 6 000
3	1 1/2, RVR or Rwy Vis > 6 000

An RVR report takes precedence over a runway visibility report or a ground visibility report, and a runway visibility report takes precedence over a ground visibility report. Ground visibility will only impose an approach ban at aerodromes south of 60°N latitude. If no RVR, runway visibility, or ground visibility is reported there are no criteria to impose an approach ban. (This concept is similar to the present CAR 602 approach ban, where if there is no RVR reported, there is no criterion to impose an approach ban.)

The following exceptions to the above prohibitions apply to aeroplanes when:

- (a) the visibility report is below the required value and the aircraft has passed the FAF inbound, or where there is no FAF, the point where the final approach course is intercepted; or
- (b) the RVR is varying between distances less than and greater than the minimum RVR.



9.19.2.6 Runway Visibility

CAR 602.131 specifies the concept of runway visibility as defined in CAR 101.01(1). The purpose of runway visibility is to determine and report a visibility at the TDZ of a runway that is not equipped with or is not reporting an RVR. An instrument-rated pilot or a qualified person (under CAR 804) can assess runway visibility when RVR sensor detection equipment is not available. In effect, a person is permitted to assess runway visibility from approximately the same position as an RVR “A” sensor installation. CAR Standard 622.131 (for pilots) and CAR Standard 824.25 (for qualified persons) describe how to assess and report runway visibility.

Runway visibility is assessed at or adjacent to the runway threshold, in the direction of the runway, based on runway lights or landmarks that can be seen and recognized. The assessment is made in feet based on a 200-ft runway edge light spacing, or using landmarks found on the applicable CAP aerodrome chart. A report of runway visibility should be reported immediately to ATS in the following format:

“RUNWAY VISIBILITY, RUNWAY [runway number] ASSESSED AS [distance assessed] FEET AT [time] UTC,” to the nearest 100-ft increment.

A runway visibility report is valid for a period of 20 min after it is assessed. If the runway visibility varies during the assessment, the lowest value is reported. The lowest value that is reported is 200 ft, with lower values reported as “... LESS THAN 200 FEET...” The highest value that is reported is 6 000 ft, with higher values reported as “... GREATER THAN 6 000 FEET ...”

9.19.2.7 Localized Phenomenon

CAR 700.10 recognizes that certain localized meteorological conditions can reduce the reported ground visibility, thus imposing an approach ban when the flight visibility appears to be much greater. An example would be a localized fog bank that is covering the ground observer’s observation point, resulting in a reported ground visibility of one-quarter statute mile at an aerodrome south of 60°N latitude, while the flight visibility along the approach to the runway and on the runway itself (as observed by the pilot-in-command), is greater than 15 SM. In this case, the pilot can declare a localized phenomenon, and override an approach ban imposed by a ground visibility report. A pilot cannot use localized phenomena to override an RVR or a runway visibility report that imposes an approach ban. To legally continue the approach past the FAF inbound, the flight visibility on the approach path and along the runway must be equal to or greater than the advisory visibility published in the CAP, for the procedure flown, and the pilot-in-command must immediately report the conditions observed to ATS.

CAUTION:

Pilots are reminded of the insidious hazard that thin ground-based layers, such as shallow fog, ice fog, or blowing snow can present. Such conditions may allow a pilot-in-command to override an approach ban based on what appears to be a localized phenomenon, when in fact extensive and very poor visibility will be encountered at low altitude during the later stages of the approach, landing and roll-out. The pilot-in-command should take all possible information into account before overriding an approach ban, based on what appears to be a localized phenomenon, in order to avoid conducting an approach during these hazardous conditions.

9.19.2.8 Effects of the High-Intensity Approach Lighting (HIAL) System on *Canada Air Pilot (CAP) Advisory Visibility and on Runway Certification*

Instrument approach procedures developed for runways with HIAL systems receive a credit against their CAP advisory visibility (by up to ½ SM). When these lighting systems are inoperative, adjustments to the approach minima must be made by the pilot as indicated in the tables below. This includes cases when the HIAL system is continuously operating on only one of the normally available intensity levels and changes to the intensity cannot be selected or requested by the pilot during the approach. These approach minima adjustments may determine whether or not the pilot is prohibited from completing an instrument approach past the FAF (see RAC 9.19.2).

HIAL systems in Canada include SSALR (“AN” in the CAP), ALSF-2 (“AL” in the CAP), and SSALS (“AW” in the CAP). Also included are the following older types of systems: CAT I High Intensity (also known as ALSF-1 or as “AE” in the CAP) and CAT II High Intensity (“AC” in the CAP). All of these systems, except for SSALS, are used to certify a precision approach runway.

When the HIAL system is inoperative, a certified precision runway is downgraded to a non-precision runway. For this reason, an approach procedure with straight-in minima below a DH of 250 ft, and below an advisory visibility of 1 SM (RVR 50), must have its minima increased to 250 ft DH and 1 SM (RVR 50) visibility when the HIAL is inoperative. For example:

Table 9.11—Straight-in minima corrections for a DH below 250 ft

HIAL Operational (published)		HIAL Inoperative	
DH (ft)	Advisory Visibility (SM)	DH (ft)	Advisory Visibility (SM)
200 - 249	½ (RVR 26)	250	1 (RVR 50)

For approach procedures with straight-in minima of 250 ft DH/HAT or greater, the advisory visibility must be increased if any of the HIAL systems become inoperative, as indicated in the following table. No increase to the DH/HAT itself is required.

No adjustment to circling minima is required based on the operating condition of the HIAL systems.

Table 9.12—Advisory visibility corrections for a DH/HAT equal to or greater than 250 ft

DH/HAT (ft)	Advisory Visibility when HIAL is Operational (published) (SM)	Advisory Visibility when HIAL is Inoperative (SM)
250 – 347	1	1
348 – 434	1	1 ¼
435 – 521	1	1 ½
522 – 608	1 ¼	1 ¾
609 – 695	1 ½	2
696 – 782	1 ¾	2 ¼
783 – 869	2	2 ½
870 – 956	2 ¼	2 ¾
957 and above	2 ½	3

9.19.3 Landing Minima

CAR 602.128 specifies that landings are governed by published DH/MDAs. Pilots of aircraft on instrument approaches are prohibited from continuing the final approach descent below DH or descending below MDA, as applicable, unless the required visual reference has been established and maintained in order to complete a safe landing. When the required visual reference is not established or maintained, a missed approach must be initiated. Pilots must be cautioned that the missed approach segment that provides for obstacle clearance originates at the published MAP. The published MAP on a precision approach is coincidental with the DH. Obstacle clearance will not be assured for missed approaches initiated beyond the MAP.

NOTE:

Certain published approaches that contain multiple lines of minima may have step-down altitudes that are lower than a published line of minima. Pilots should not descend to a step-down altitude that is lower than the altitude on their selected line of minima.

The visual references required by the pilot to continue the approach to a safe landing should include at least one of the following references for the intended runway, and should be distinctly visible and identifiable to the pilot by:

- (a) the runway or runway markings;
- (b) the runway threshold or threshold markings;
- (c) the touchdown zone or touchdown zone markings;
- (d) the approach lights;
- (e) the approach slope indicator system;
- (f) the runway identification lights;
- (g) the threshold and runway end lights;
- (h) the touchdown zone light;
- (i) the parallel runway edge lights; or
- (j) the runway centreline lights.

Aerodromes that have instrument approaches may not have all of the above items, therefore pilots should consult the appropriate charts and current NOTAM to ascertain the available aids.

Published landing visibilities associated with all instrument approach procedures are advisory only. Their values are indicative of visibilities which, if prevailing at the time of approach, should result in required visual reference being established. (See GEN 5.1 for the definition.) They are not limiting and are intended to be used by pilots only to judge the probability of a successful landing when compared against available visibility reports at the aerodrome to which an instrument approach is being carried out.

9.20 Runway Visual Range (RVR)

9.20.1 Definitions

Prevailing Visibility: The maximum visibility value common to sectors comprising one-half or more of the horizontal circle.

NOTE:

Prevailing visibility is determined by human observations.

Runway Visual Range (RVR): in respect of a runway, means the maximum horizontal distance, as measured by an automated visual landing distance system and reported by an ATC unit or an FSS for the direction of takeoff or landing, at which the runway, or the lights or markers delineating it, can be seen from a point above its centreline at a height corresponding to the average eye level of pilots at touchdown.

To compute RVR, three factors must be known. The first is the transmissivity of the atmosphere as provided by a visibility sensor. The second is the brightness of the runway lights which is controlled on request by the ATC controller. The third factor is whether it is day or night, since the eye can detect lights easier at night than during the day. There is a period during twilight where there is a problem similar to that with prevailing visibility when neither day, nor night conditions prevail.

RVR is measured by a visibility sensor such as a RVR sensor located near the runway threshold. For CAT II landing systems, a second sensor is provided about the mid-point of the runway. The RVR sensor near the threshold is identified as “A” and the second one as “B”. Their locations are important for the assessment of visibility, and so their positions are indicated on the aerodrome diagrams in CAP.

A light emitted from a source is attenuated in the atmosphere due to snow, fog, rain, and so forth. The amount of this attenuation, or the transmissivity of the atmosphere, can be obtained by measuring the amount of light reaching a detector after being transmitted by a projector. The visibility sensor samples the atmosphere at a height that best represents the slant transmittance from the pilot’s eye at cockpit level to the runway.

9.20.2 Operational Use of Runway Visual Range (RVR)

RVR information is available at the ATC IFR arrival control position, the PAR position, the control tower and the FSS.

When applicable, RVR information is given to the pilot as a matter of routine and can be used in the determination or application of visibility minima only if the active runway is served by the visibility sensor. RVR information, found in the Remarks section of surface weather reports, is not to be used for operational purposes and is superseded by any RVR information from ATS personnel.

NOTE:

RVR reports are intended to provide an indication of how far the pilot can expect to see along the runway in the touchdown zone; however, the actual visibility at other points along the runway may differ due to differing weather conditions. This

should be taken into account when decisions must be made based on reported RVR.

A pertinent phenomenon that occurs fairly often during periods of low visibility is large fluctuations that occur over extremely short time intervals. As per ICAO recommendations, the RVR computer automatically averages the readings over the last minute.

The controller will provide the RVR if it is less than 6 000 ft, or upon request. The RVR will be provided in 100-ft increments from 300 ft to 1 199 ft, in 200-ft increments from 1 200 ft to 2 999 ft, and in 500-ft increments from 3 000 ft to 6 000 ft. The RVR remains constant for runway light settings of 1, 2 and 3, but it can increase for settings of 4 and 5. If the latter settings are used, the pilot will be provided with both the RVR and the light setting.

NOTE:

At aerodromes equipped with ARCAL, the light settings may not be known to ATS personnel.

In daytime, even a high intensity setting can fade into background brightness. For example, the pilot may be provided with an RVR of 4 000 ft while making an approach when shallow fog is occurring over a snow surface in bright sunlight. Because of the glare, runway lights will be difficult to see; therefore, visibility will be much less than the reported RVR. In situations such as this, the use of prevailing visibility would be more appropriate.

RVR may be used instead of prevailing visibility for landing and take-off minima, but only for runways equipped with an RVR system. In such cases, the following table can be used.

Table 9.13—RVR to Be Used Instead of Prevailing Visibility for Landing and Take-Off Minima on Equipped Runways

GROUND VISIBILITY	RVR
1 mile	5 000 feet
3/4 mile	4 000 feet
1/2 mile	2 600 feet
1/4 mile	1 200 feet
See Note 2	under 1 200 feet

NOTES:

1. A comparative scale converting RVR-feet into RVR-metres is shown in the GEN section.
2. Ground visibility does not apply to operators with a takeoff limit below 1 200 feet.

ATS phraseology applicable to the foregoing is as follows:

- (a) Runway (number) visual range/ RVR three thousand five hundred feet.
- (b) Runway (number) visual range/ RVR less than three hundred feet.
- (c) Runway (number) visual range/ RVR more than six thousand feet.
- (d) Runway (number) visual range/ RVR (number) feet, fluctuating (number) to (number) feet, visibility (fraction) mile.
- (e) Runway (number) visual range/ RVR (number) feet, runway lights at setting four/five.
- (f) Runway (number) visual range/ RVR ALFA (number) feet, BRAVO (number) feet, CHARLIE (number) feet.

9.21 Aircraft Approach Categories

Aircraft performance has a direct effect on the airspace and visibility required for the various manoeuvres associated with the conduct of an instrument approach procedure. The most significant performance factor is aircraft speed. For this reason, a number of aircraft approach categories, each with a specified speed range, have been established.

An aircraft’s approach category is determined based on its reference landing speed (V_{ref}), if specified, or if V_{ref} is not specified, 1.3 times stall speed (V_{so}) at the maximum certificated landing weight. V_{ref} , V_{so} , and the maximum certificated landing weight are those values as established for the aircraft by the certification authority of the country of registry. The categories are as follows:

Table 9.14—Aircraft Approach Categories

CATEGORY	A	B	C	D	E
SPEEDS	up to 90 KIAS (includes all rotorcraft)	91 to 120 KIAS	121 to 140 KIAS	141 to 165 KIAS	above 165 KIAS

NOTE:

Category E minima are not provided on civil instrument approach procedure charts.

An aircraft’s approach category does not change if the actual landing weight is less than the maximum certificated landing weight. The certificated approach category is permanent and independent of the changing conditions of day-to-day operations. An aircraft is certificated in only one approach category and cannot be flown to the minima of a slower approach category. For example, a Category C aircraft cannot utilize Category B minima.

However, if the requirement for a faster approach speed places the aircraft in a higher speed approach category, the minima for the appropriate higher category must be used. This may be due to operational circumstances such as emergency returns requiring overweight landing or approaches made with inoperative flaps or in icing conditions. Additionally, if it is necessary to

visually manoeuvre at speeds in excess of the upper limit of a speed range for a category, the minima for the category for that higher speed must be used. For example, an aircraft which falls in Category A, but is circling to land at a speed in excess of 90 kt, must use the approach Category B minima when circling to land.

9.22 Straight-In Landing Minima

Minima for a straight-in landing are published when a normal rate of descent can be made from the final approach fix (FAF) to the runway threshold and when the final approach track intersects the extended runway centre-line within 30° and within a prescribed distance from the threshold. When either the normal rate of descent or the runway alignment exceeds the criteria, straight-in landing minima are not published and only circling minima apply. The fact that only circling minima are published does not preclude a pilot from landing straight-in if the required visual reference is available in sufficient time to make a normal approach and landing.

NOTE:

The term straight-in used in connection with landing should not be confused with its use in straight-in approach minima. An ATC clearance for a straight-in approach merely clears the aircraft for an approach without first completing a procedure turn. The minima that will subsequently be used will be based on considerations such as the runway in use, published minima, aircraft category, etc.

The use of straight-in landing minima is predicated upon the pilot having the wind direction and speed and runway condition reports required to conduct a safe landing. At an uncontrolled aerodrome where the pilot may lack the necessary information, the pilot is expected to verify that the runway is unobstructed prior to landing. In some cases, this can only be accomplished by conducting a circling approach using the appropriate circling minima.

At an uncontrolled aerodrome, runway conditions (including any temporary obstructions such as vehicles) may be determined by the pilot by:

- (a) contacting the appropriate FSS or UNICOM at the destination;
- (b) a pre-flight telephone call to the destination to arrange for making the necessary information available when required for landing;
- (c) a visual inspection;
- (d) a NOTAM issued by the aerodrome operator; or
- (e) any other means available to the pilot, such as message relay from preceding aircraft at the destination.

9.23 Circling

Circling is the term used to describe an IFR procedure that is conducted by visually manoeuvring an aircraft, after completing an instrument approach, into position for landing on a runway which is not suitably located for a straight-in landing (not usually applicable to rotorcraft).

The visual manoeuvring area for a circling approach is determined by drawing arcs centred on each runway threshold and joining those arcs with tangent lines. The radius of the arcs is related to the aircraft category and may be based on either standard circling approach radii or expanded circling approach radii (see sections 9.23.1 and 9.23.2 below). The circling minimum descent altitude (MDA) provides a minimum of 300 feet above all obstacles within the visual manoeuvring area for each category.

Figure 9.15—Visual Manoeuvring (Circling) Area

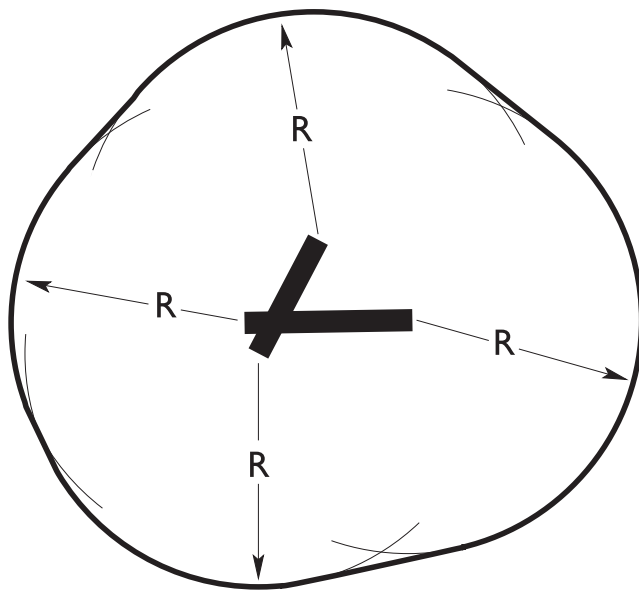

If it is necessary to manoeuvre an aircraft at a speed in excess of the upper limit of the speed range for its approach category, the circling minima for the next higher category should be used in order to ensure appropriate protection from obstacles.

Circling restrictions are published at some locations to prevent circling manoeuvres in certain sectors or directions where higher terrain or prominent obstacles exist. This practice allows the publication of lower minima than would otherwise be possible. In such cases, the circling MDA DOES NOT PROVIDE OBSTACLE CLEARANCE WITHIN THE RESTRICTED SECTOR.

9.23.1 Standard Circling Approach Radii

Circling approach protected areas developed prior to 2020 used the radius distances shown in the following table. Approaches using standard circling approach areas can be identified by the absence of the **C** symbol on the circling line of minima.

Table 9.15 — Standard Circling Approach Radii

Circling MDA in feet AMSL	Approach Category and Circling Radius (NM)				
	CAT A	CAT B	CAT C	CAT D	CAT E*
All altitudes	1.3	1.5	1.7	2.3	4.5

*Category E circling minima are published at DND aerodromes only.

9.23.2 Expanded Circling Approach Radii

Circling approach protected areas developed in 2020 or later use a radius distance based on the aircraft category as well as the altitude of the circling MDA, which accounts for increases to true airspeed with altitude. The following table provides radius values for each aircraft category within five altitude bands. Approaches using expanded circling approach areas can be identified by the presence of the **C** symbol on the circling line of minima.

Table 9.16 — Expanded Circling Approach Radii

Circling MDA in feet AMSL	Approach Category and Circling Radius (NM)				
	CAT A	CAT B	CAT C	CAT D	CAT E*
—					
1000 or less	1.3	1.7	2.7	3.6	4.5
1001 – 3000	1.3	1.8	2.8	3.7	4.6
3001 – 5000	1.3	1.8	2.9	3.8	4.8
5001 – 7000	1.3	1.9	3.0	4.0	5.0
7001 – 9000	1.4	2.0	3.2	4.2	5.3

*Category E circling minima are published at DND aerodromes only.

9.24 Circling Procedures

An air traffic controller may specify manoeuvring in a certain direction or area due to traffic considerations; however, the selection of the procedure required to remain within the protected area and to accomplish a safe landing rests with the pilot. There can be no single procedure for conducting a circling approach due to variables such as runway layout, final approach track, wind velocity and weather conditions. The basic requirements are to keep the runway in sight after initial visual contact, and remain at the circling MDA until a normal landing is assured. Examples of various circling approach situations are illustrated in Figure 9.12.

Figure 9.16—Typical Circling Manoeuvres

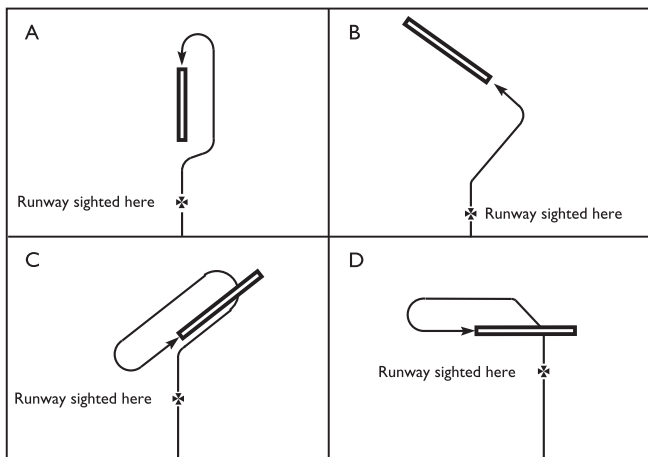

9.25 Missed Approach Procedure While Visually Manoeuvring in the Vicinity of the Aerodrome

The pilot may have to conduct a missed approach after starting visual manoeuvres. There are no standard procedures in this situation. Thus, unless the pilot is familiar with the terrain, it is recommended that:

- (a) a climb be initiated;
- (b) the aircraft be turned towards the centre of the aerodrome; and
- (c) the aircraft be established, as closely as possible, in the missed approach procedure published for the instrument approach procedure just completed.

With the runway in sight at circling MDA, the pilot should execute the missed approach if there is any doubt that the ceiling and visibility are inadequate for manoeuvring safely to the point of touchdown.

9.26 Missed Approach Procedures

Whenever a pilot conducts a published missed approach from an instrument approach procedure, the aircraft must continue along the published final approach course to the published Missed Approach Point (MAP) and follow the published missed approach instructions. The pilot may climb immediately to the altitude specified in the missed approach procedure or assigned by ATC. In the event of a missed approach when no missed

approach clearance has been received, the pilot will follow the published missed approach instructions. Should the pilot arrive at the missed approach holding fix prior to receiving further clearance, the pilot will:

- (a) hold in a standard holding pattern on the inbound track used to arrive at the fix;
- (b) if there is a published missed approach track to the fix, hold in a standard holding pattern inbound to the fix on this track;
- (c) if there is a published shuttle or holding pattern at the fix, hold in this pattern regardless of the missed approach track to the fix; or
- (d) if there are published missed approach holding instructions, hold in accordance with these.

If a clearance to another destination has been received, the pilot shall, in the absence of other instructions, carry out the published missed approach instructions until at an altitude which will ensure adequate obstacle clearance before proceeding on course.

If specific missed approach instructions have been received and acknowledged, the pilot is required to comply with the new missed approach instructions before proceeding on course, e.g. “on missed approach, climb runway heading to 3 000 feet; right turn, climb on course” or “on missed approach, climb straight ahead to the BRAVO NDB before proceeding on course”.

Civil and military air traffic control procedures do not require the air traffic controller to provide terrain and obstacle clearance in their missed approach instructions. Terms such as “on missed approach, right turn climb on course” or “on missed approach, left turn on course” are not to be considered specific missed approach instructions. It remains the pilot’s responsibility to ensure terrain and obstacle avoidance and clearance.

The terrain and obstacle environment in the missed approach segment may require a climb gradient greater than the standard 200 ft/NM (or 400 ft/NM for helicopter-only procedures). The pilot must plan in advance to ensure that the aircraft can meet the climb gradient required by the procedure in the event of a missed approach and must also be aware that flying at a ground speed higher than anticipated will increase the climb rate requirement (feet per minute). Where aircraft limitations or other factors preclude the pilot from following the published climb gradient, it is the responsibility of the pilot-in-command (PIC) to determine alternative procedures that will take into account obstacle and terrain clearance.

9.27 Simultaneous Precision Instrument Approaches - Parallel Runways

When simultaneous precision instrument approaches are in progress, ATC will vector arriving aircraft to one or the other of the parallel localizers for a straight-in final approach. (When cleared for a straight-in approach, a procedure turn is not permitted.) Each of the parallel approaches has a “high side” and a “low side” for vectoring and to allow for vertical separation until both aircraft are established inbound on their respective parallel localizer (LOC).

The pilot will be instructed to change and report on the tower

frequency prior to reaching the final approach fix (FAF) inbound. If an aircraft is observed to overshoot the localizer during the final turn, the pilot will be instructed to return to the correct localizer course immediately. After an aircraft is established on the localizer, the controller monitoring the final approach will issue control instructions only if an aircraft deviates or is expected to deviate by 1 500 ft from the localizer centreline. Information or instructions issued by the monitoring controller will be aimed at returning the aircraft to the localizer course. If the aircraft fails to take corrective action, the aircraft on the adjacent localizer may be issued appropriate control instructions. Monitoring of the approach is terminated without notification to the pilot when the aircraft is 1 NM from the runway threshold. If considered necessary, appropriate missed approach instructions will be issued.

THE APPROACH CLEARANCE WILL INCLUDE AN ALTITUDE THAT MUST BE MAINTAINED UNTIL INTERCEPTING THE GLIDE PATH. If the glide path is inoperative, the pilot will be cleared to maintain an altitude to a specified distance measuring equipment (DME) distance before commencing the descent.

When informed by automatic terminal information service (ATIS) or by the arrival controller that simultaneous precision instrument approaches are in progress, pilots should advise the arrival controller immediately of any avionics unserviceabilities having an impact on their capabilities to accept this procedure.

9.28 Simultaneous Precision Instrument Approaches - Converging Runways

ATC may clear pilots for precision instrument approaches simultaneously to converging runways at airports where this procedure has been approved.

Aircraft will be informed through ATIS or by the arrival controller as soon as feasible after initial contact when simultaneous precision instrument approaches to converging runways are in progress. When simultaneous approaches are in progress, ATC will vector arriving aircraft to the appropriate runway localizer for a straight-in final approach. Pilots should advise the arrival controller immediately of any malfunctioning or inoperative equipment making this procedure undesirable.

These are the restrictions for simultaneous precision approaches to converging runways:

- (a) Converging runways (defined as an included angle between 15° and 100°).
- (b) ATIS surveillance available.
- (c) Precision instrument approach systems (ILS/MLS) operating on each runway.
- (d) Non-intersecting final approach courses.
- (e) Missed approach points at least 3 NM apart.
- (f) Non-overlapping primary missed approach protected airspace.
- (g) Separate instrument approach charts denoting the procedures.
- (h) If runways intersect, tower controllers must be able to apply visual separation as well as intersecting runway separation criteria.
- (i) Only straight-in approaches and landing are authorized.

To emphasize the protection of active runways and to aid in preventing runway incursions, landing instructions which include the words “HOLD SHORT” should be acknowledged by a readback of the hold point by the pilot.

10.0 Instrument Flight Rules (IFR) — Holding Procedures

10.1 General

Pilots are expected to adhere to the aircraft entry and holding manoeuvres, as described in RAC 10.5, since ATC provides lateral separation in the form of airspace to be protected in relation to the holding procedure.

10.2 Holding Clearance

A holding clearance issued by ATC includes at least

- (a) a clearance to the holding fix;
- (b) the direction to hold from the holding fix;
- (c) a specified radial, course, or inbound track;
- (d) if DME is used, the DME distances at which the fix end and outbound end turns are to be commenced (e.g. hold between [number of miles] and [number of miles]);

NOTE:

In the absence of an outbound DME being issued by ATC, pilots are expected to time the holding pattern in accordance with subsections below.

- (e) the altitude or FL to be maintained; and
- (f) the time to expect further clearance or an approach clearance; or
- (g) the time to leave the fix in the event of a communications failure.

NOTE:

An expect-further-clearance time is usually followed by further en route clearance, which is followed by an expect-approach-clearance time when traffic conditions permit.

During entry and holding, pilots manually flying the aircraft are expected to make all turns to achieve an average bank angle of at least 25° or a rate of turn of 3° per second, whichever requires the lesser bank. Unless the ATC clearance contains instructions to the contrary, or a non-standard holding pattern is published at the holding fix, pilots are expected to make all turns to the right after initial entry into the holding pattern.

Occasionally, a pilot may reach a clearance limit before obtaining further clearance from ATC. In this event, where a holding pattern is published at the clearance limit, the pilot is to hold as published. Where no holding pattern is published, the pilot is to hold in a standard pattern on the inbound track to such clearance limit and request further clearance.

If communication cannot be established with ATC, the pilot should then proceed in accordance with communication failure procedures.

Examples

1. A westbound flight on R77, cleared to Greely NDB (YRR) reaches Ottawa before obtaining further clearance. The pilot is to hold at YRR on an inbound track of 287° and request further clearance.
2. The published missed approach procedure for an ILS RWY 23 approach at Halifax is the following:
“CLIMB TO 2 200 ON TRACK OF 234° TO “ZHZ” NDB.”

A pilot missing an ILS approach to RWY 23 and not in receipt of further clearance is to proceed directly to the “ZHZ” NDB, make a right turn and hold at the “ZHZ” beacon on an inbound track of 234° and request further clearance.

If for any reason a pilot is unable to conform to these procedures, ATC should be advised as early as possible.

10.3 Standard Holding Pattern

A standard holding pattern is depicted in Figure 10.1 in terms of still air conditions.

Figure 10.1—Standard Holding Pattern

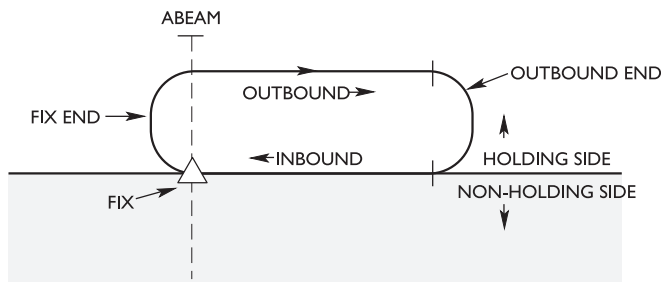

Having entered the holding pattern, on the second and subsequent arrivals over the fix, the pilot executes a right turn to fly an outbound track that positions the aircraft most appropriately for the turn onto the inbound track. When holding at a VOR, the pilot should begin the turn to the outbound leg at the time of station passage as indicated on the TO-FROM indicator.

Continue outbound for one minute if at or below 14 000 ft ASL, or one and a half minutes if above 14 000 ft ASL. (ATC specifies distance, not time, where a DME fix is to be used for holding.)

Turn right to realign the aircraft on the inbound track.

10.4 Non-Standard Holding Pattern

A non-standard holding pattern is one in which

- (a) the fix end and outbound end turns are to the left; and/or
- (b) the planned time along the inbound track is other than the standard one-minute or one-and-a-half minute leg appropriate for the altitude flown.

10.5 Entry Procedures

The pilot is expected to enter a holding pattern according to the aircraft’s heading in relation to the three sectors shown in Figure 10.2, recognizing a zone of flexibility of five degrees on either side of the sector boundaries. For holding on VOR intersections or VOR/DME/TACAN (VHF omnidirectional range/distance measuring equipment/tactical air navigation aid) fixes, entries are limited to the radials or DME arcs forming the fix, as appropriate.

Figure 10.2—Entry Sectors

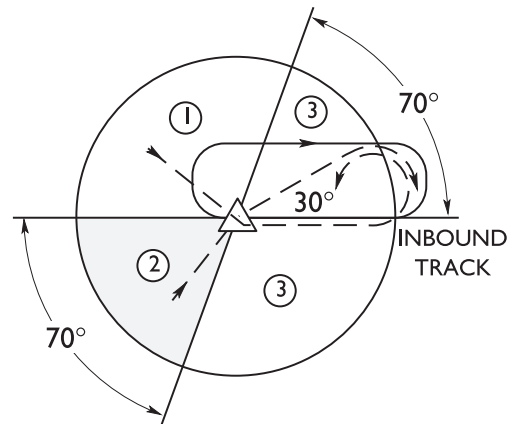

Sector 1 procedures (parallel entry) are:

- (a) Upon reaching the fix, turn onto the outbound heading of the holding pattern for the appropriate period of time.
- (b) Turn left to intercept the inbound track or to return directly to the fix.
- (c) On the second arrival over the fix, turn right and follow the holding pattern.

Sector 2 procedures (offset entry) are:

- (a) Upon reaching the fix, turn to a heading that results in a track having an angle of 30° or less from the inbound track reciprocal on the holding side.
- (b) continue for the appropriate period of time, then turn right to intercept the inbound track and follow the holding pattern.

Sector 3 procedure (direct entry) is:

- (a) Upon reaching the fix, turn right and follow the holding pattern.

Entry procedures to a non-standard pattern requiring left turns are oriented in relation to the 70° line on the holding side (Figure 10.3), just as in the standard pattern.

Figure 10.3—Left Hand Pattern Entry

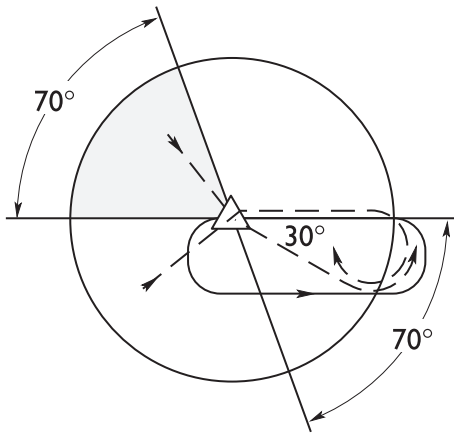

When crossing the fix to enter a holding pattern, the appropriate ATC unit should be advised. ATC may also request that the pilot report “established in the hold”. The pilot is to report “established” when crossing the fix after having completed the entry procedure.

10.6 Timing

The still air time for flying the outbound leg of a holding pattern should not exceed 1 min if at or below 14 000 ft ASL, or 1 1/2 min if above 14 000 ft ASL; however, the pilot should make due allowance in both heading and timing to compensate for wind effect.

After the initial circuit of the pattern, timing should begin abeam the fix or on attaining the outbound heading, whichever occurs later. The pilot should increase or decrease outbound times, in recognition of winds, to effect 1 or 1 1/2 min (appropriate to altitude) inbound to the fix.

When the pilot receives ATC clearance specifying the time of departure from the holding fix, adjustments should be made to the flight pattern within the limits of the established holding pattern to leave the fix as close as possible to the time specified.

10.7 Speed Limitations

The size of the protected airspace for a holding pattern is based on aircraft speed. Unless otherwise noted on the charts or when a shuttle procedure is specified (see RAC 10.9), holding patterns must be entered and flown at or below the airspeeds listed in Table 10.1 below:

Table 10.1—Maximum Holding Airspeeds

Altitude (ASL)	Maximum Holding Airspeed (KIAS)
At or below 6 000 ft	200
Above 6 000 ft up to and including 14 000 ft	230
Above 14 000 ft	265

NOTES:

1. At Canadian military airfields, the size of the protected airspace is for a maximum of 310 KIAS, unless otherwise noted.
2. For helicopter procedures (COPTER), the maximum holding airspeed is 90 KIAS, unless otherwise noted.

Pilots are to advise ATC immediately if airspeeds in excess of those specified above become necessary for any reason, including turbulence, or if they are unable to accomplish any part of the holding procedure.

After departing a holding fix, pilots should resume normal speed subject to other requirements, such as speed limitations in the vicinity of controlled airports, specific ATC requests, etc.

NOTE:

In areas where turbulence is known to exist, holding patterns may be designed for speeds of 280 KIAS.

10.8 Distance Measuring Equipment (DME) Procedures

DME holding is subject to the same entry and holding procedures previously described except that distances, in NM are used in lieu of time values. In describing the direction from the fix on which to hold and the limits of a DME holding pattern, an ATC clearance will specify the DME distance from the navigation aid at which the inbound and outbound legs are to be terminated. The end of each leg is determined by the DME indications.

Figure 10.4—DME Hold

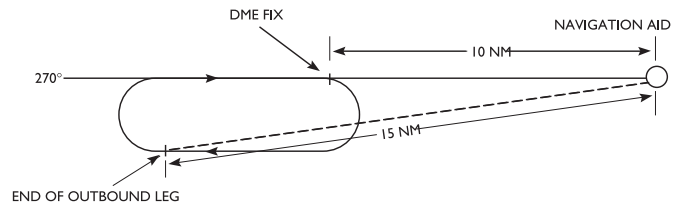

Example:

An aircraft cleared to the 270° RADIAL 10 mile DME FIX, to HOLD BETWEEN 10 AND 15 miles, will hold inbound on the 270° radial, commence turn to the outbound leg when the DME indicates 10 NM and commence turn to inbound leg when the DME indicates 15 NM.

10.9 Shuttle Procedure

A shuttle procedure is defined as a manoeuvre involving a descent or climb in a pattern resembling a holding pattern. Shuttles are generally prescribed on instrument procedure charts located in mountainous areas. In the approach phase, it is normally prescribed where a descent of more than 2 000 ft is required during the initial or intermediate approach segments. It can also be required when flying a missed approach or departure procedure from certain airports in the vicinity of mountain ranges. A shuttle procedure shall be executed in the pattern as published unless instructions contained in an ATC clearance

direct otherwise.

To ensure that the aircraft does not exceed the obstacle clearance protected airspace during a shuttle descent or climb, the aircraft must not exceed:

- (a) the airspeed limit published on instrument procedure charts or, if no airspeed limit is published, the following limits:
 - (i) For climbs, the maximum airspeed is 310 KIAS.
 - (ii) For descents, the maximum airspeeds from Table 10.1 apply;
- (b) the outbound/inbound still air time restrictions;
- (c) the DME holding restrictions.

NOTE:

All shuttle climb airspeeds are subject to CAR 602.32.

10.10 Holding Patterns Published on Enroute and Terminal Charts

At some high traffic density areas, holding patterns are depicted on IFR Terminal Area and Enroute charts. When pilots are cleared to hold at a fix where a holding pattern is published, or if clearance beyond the fix has not yet been received, pilots are to hold according to the depicted pattern using normal entry procedures and timing in the hold as described above. ATC will use the following phraseology when clearing an aircraft holding at a fix that has a published holding pattern;

CLEARED TO THE (fix), HOLD (direction) AS PUBLISHED EXPECT FURTHER CLEARANCE AT (time)

NOTE:

The holding direction means the area in which the hold is to be completed in relation to the holding fix, e.g. east, northwest, etc. If a pattern is required that is different than that published, detailed holding instructions will be issued by ATC.

If a pilot is instructed to depart a fix that has a published hold, at a specified time, the pilot has the option to:

- (a) proceed to the fix, then hold until the “depart fix” time specified;
- (b) reduce speed to make good his “depart fix” time; or
- (c) a combination of (a) and (b).

11.0 Air Traffic Control (ATC) Special Procedures

11.1 Adherence to Mach Number

Within CDA, aircraft shall adhere to the Mach number assigned by ATC, to within 0.01 Mach, unless approval is obtained from ATC to make a change or until the pilot receives the initial descent clearance approaching destination. If it is necessary to make an immediate temporary change in the Mach number (e.g. because of turbulence), ATC shall be notified as soon as possible

that such a change has been made.

If it is not possible to maintain the last assigned Mach number during en route climbs and descents because of aircraft performance, pilots shall advise ATC at the time of the climb/descent request.

11.2 Parallel Offset Procedures

ATC may request that an aircraft fly a parallel offset from an assigned route. This manoeuvre and subsequent navigation is the responsibility of the pilot. When requested to offset or regain the assigned route, the pilot should change heading by 30° to 45° and report when the offset or assigned route is attained.

In an ATS surveillance environment, ATC will provide ATS surveillance monitoring and the required separation.

In a non-ATS surveillance environment, ATC will apply parallel offsets to RNP-C-certified aircraft operating within high-level RNP-C airspace in order to accomplish an altitude change with respect to same direction aircraft.

The following phraseology is normally used for parallel offset procedures:

PROCEED OFFSET (number) MILES (right/left) OF CENTRELINE (track/route) AT (significant point/time) UNTIL (significant point/time).

11.3 Structured Airspace

During specific periods, certain portions of domestic high-level airspace may be structured for one-way traffic in which cruising flight levels inappropriate to the direction of the aircraft track may be assigned by ATC. Aircraft operating in a direction contrary to the traffic flow will be assigned those cruising flight levels appropriate to the direction of track except in specific instances, such as turbulence. When the airspace is not structured for one-way traffic, appropriate cruising flight levels will be used. ATC will transition aircraft to the appropriate cruising flight level for the direction of track before aircraft exit the defined areas or before termination of the indicated times.

11.4 Canadian Domestic Routes

11.4.1 General

Within North American Airspace, various route and track systems exist in order to provide effective management of airspace and traffic. Under specified conditions, random routes may be included in a flight plan or requested.

11.4.2 North American Route Program (NRP)

11.4.2.1 Introduction

The North American Route Program (NRP) is a joint FAA and NAV CANADA program that allows air operators to select operationally advantageous routings. The objective of the NRP is to harmonize and adopt common procedures, to the extent possible, applicable to random route flight operations at and

above FL 290 within the conterminous U.S. and Canada.

The NRP will be implemented through various phases with the end goal of allowing all international and domestic flight operations to participate in the NRP throughout the conterminous U.S. and Canada.

11.4.2.2 Eligibility

Flights may participate in the NRP under specific guidelines and filing requirements:

- (a) provided the flight originates and terminates within conterminous U.S. and Canada; or
- (b) for North Atlantic international flights, provided that they are operating within the North American Route (NAR) System.

11.4.2.3 Procedures

NRP common procedures and specific NAV CANADA requirements are contained in the “Planning” section of the CFS.

11.4.3 Mandatory Instrument Flight Rules (IFR) Routes

Air traffic controllers and ATS automated systems rely on certain set routes in order to plan systematic air traffic flows, a process that is critical for reducing delays. Mandatory IFR routes provide guidance in planning routes, minimize route changes, and allow for efficient departure, en route, and arrival ATS while also reducing communication and the potential for readback and FMS input errors.

Procedures for and descriptions of mandatory routes are published in the “Planning” section of the CFS.

11.4.4 Fixed Area Navigation (RNAV) Routes

Published fixed RNAV routes can be flight planned for use by aircraft with RNAV capability, subject to any limitations or requirements noted on the en route charts, in applicable advisory circulars, or by NOTAM.

- (a) Q-routes are high-level fixed RNAV routes depicted on En Route High Altitude charts using black dashed lines and require an RNAV system with performance capabilities currently only met by GNSS or distance measuring equipment/inertial reference unit (DME/DME/IRU) systems. DME/DME/IRU navigation may be limited in some parts of Canada owing to navigational facility coverage. In such cases, the routes will be annotated as “GNSS only” on the chart.
- (b) T-routes are low-level controlled fixed RNAV routes depicted on En Route Low Altitude charts using black dashed lines and require GNSS RNAV systems for use. The airspace associated with T-routes extends upward from 2 200 ft AGL, 10 NM either side of the centreline, and does not splay. The MOCA provides obstacle protection for only 6 NM either side of the track centreline and does not splay.
- (c) L-routes are low-level uncontrolled fixed RNAV routes

depicted on En Route Low Altitude charts using green dashed lines and require GNSS RNAV systems for use. The MOCA provides obstacle protection for only 6 NM either side of the track centreline and does not splay.

Magnetic reference bearing (MRB) is the published bearing between two waypoints on a fixed RNAV route and will be published within the SDA. The MRB is calculated by applying magnetic variation at the waypoint to the calculated true course between two waypoints. Pilots should use this bearing as a reference only, because RNAV systems will fly the true course between the waypoints. True reference bearings (TRB) will be published along fixed RNAV routes located in the NDA and shall be notated with the suffix “T.”

11.4.5 Northern Control Area (NCA) Random Routes

Within the Northern Control Area (NCA), flights operating on random routes shall flight plan and make positions reports as follows:

- (a) flights operating on predominately north or south tracks (315°T clockwise through 045°T or the reciprocals) shall report over reporting line points formed by the intersection of parallels of latitude spaced at 5° intervals expressed in latitude by whole degrees and meridians of longitude expressed in either whole degrees or whole and half degrees;
- (b) south of 75°N latitude, flights operating on predominately east or west tracks (046°T clockwise through 134°T or the reciprocals) shall report over reporting line points formed by the intersection of either whole degrees or whole and half degrees of latitude coincident with each 10° of longitude. For flights operating north of 75°N latitude, where 20° of longitude is traversed in less than 60 min, reporting line points are to be defined by parallels of latitude expressed in degrees and minutes coincident with meridians of longitude at 20° intervals;
- (c) as requested by ATS.

11.4.6 Arctic Control Area (ACA) Random Routes

Within the Arctic Control Area (ACA), flights operating on random routes shall flight plan and make positions reports as follows:

- (a) at the reporting lines coincident with 141°W, 115°W and 60°W meridians. If the route of flight is north of 87°N latitude, the 115°W report is not required;
- (b) westbound flights which do not cross the 60°W meridian on entry or prior to entry into the ACA shall report at the point of entry into the ACA;
- (c) westbound flights which do not cross the 141°W meridian prior to exiting the ACA shall report at the point of exit from the ACA;
- (d) eastbound flights which do not cross the 141°W meridian on entry into the ACA shall report at the point of entry;

- (e) eastbound flights which do not cross the 60°W meridian on or after exiting the ACA shall report the point of exit;
- (f) northbound or southbound flights which do not cross significant reporting lines shall report at the entry and exit points of the ACA; and
- (g) as requested by ATS.

11.4.7 Polar Routes

11.4.7.1 General

With the advent of aircraft capable of long-range flight, circumventing the globe via the North Pole has become routine. Polar routes are flight paths to or from the Americas and Eurasia via Russian polar airspace. Polar flights must file designated polar fixes on the Anchorage/Russian border but are otherwise random in Canadian airspace.

11.4.7.2 Flight Planning and Position Reporting

Polar routes can be flight planned by aircraft with CMNPS certification. Flight plan routing should be filed with a fix every 5° of latitude. Random points should be expressed in whole degrees of latitude and either whole degrees or whole and half degrees of longitude.

11.4.7.3 Altitude Assignment

Current cruising altitude for direction of flight requirements are based on east-west traffic flows. A shift in flight track (from east to west or vice versa) requires the assignment of a new flight level. Flights on north-south routes may shift track, from easterly to westerly or vice versa, depending on route segment. This shifting makes altitude assignment based on current regulations less than optimal.

In order to accommodate polar route flights, aircraft operating on polar routes within the Edmonton, Winnipeg and Montréal FIRs may be assigned altitudes inappropriate to the direction of flight. Altitude assignment is based on traffic management requirements for the movement of aircraft in a safe, orderly and expeditious manner.

11.5 North American Route (NAR) System

The NAR System provides an interface between NAT oceanic and domestic airspaces. Operating conditions and description of the NAR are contained in RAC 11.4 and the CFS, “Planning” section.

For a detailed description of the NAR System, refer to the CFS NORTH AMERICAN ROUTES (NARs) for NORTH ATLANTIC TRAFFIC Section 7(a), which outlines the requirements to flight plan and operate using the NAR system.

11.6 Emergency Security Control of Air Traffic (escat) Plan

(see the Emergency section of the *Canada Flight Supplement* [CFS].)

11.7 Reduced Vertical Separation Minimum (RVSM)

11.7.1 Definitions

RVSM: The application of 1000-ft vertical separation at and above FL 290 between aircraft approved to operate in reduced vertical separation minimum airspace.

Non-RVSM Aircraft: An aircraft that does not meet reduced vertical separation minimum (RVSM) requirements for certification and/or for operator approval.

RVSM Aircraft: An aircraft that meets reduced vertical separation minimum (RVSM) requirements for certification and for operator approval.

11.7.2 Reduced Vertical Separation Minimum (RVSM) Airspace

RVSM airspace is all airspace within CDA from FL 290 to FL 410 inclusive as defined in the DAH (TP 1820) and depicted in Figure 12.3.

Figure 11.1—RVSM Airspace and RVSM Transition Airspace

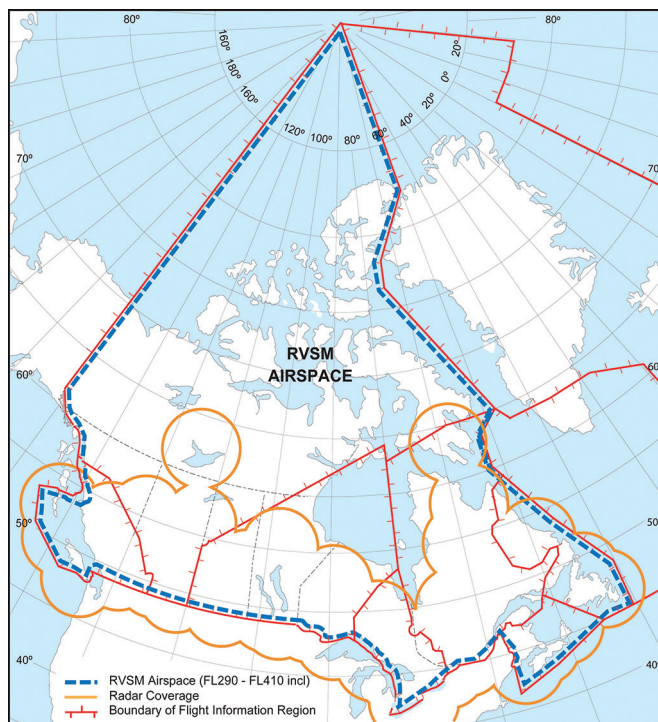

RAC

11.7.3 Air Traffic Control (ATC) Procedures

Within RVSM airspace ATC:

- (a) will, within non-ATS surveillance airspace, endeavour to establish 2 000 ft separation or applicable lateral or longitudinal separation minimum if an aircraft reports greater-than-moderate turbulence, and/or mountain wave activity that is of sufficient magnitude to significantly affect altitude-keeping, and is within 5 min of another aircraft at 1 000 ft separation;
- (b) will, within ATS surveillance airspace, vector aircraft to establish ATS surveillance separation or establish 2 000 ft separation if an aircraft reports greater-than-moderate turbulence, or encountering mountain wave activity that is of sufficient magnitude to significantly affect altitude-keeping, if 1 000 ft vertical separation exists between two aircraft, and targets appear likely to merge;
- (c) may structure portions of the airspace for specific periods of time for one-way traffic in which inappropriate flight levels to the direction of flight may be assigned; and
- (d) may, within non-ATS surveillance airspace, temporarily suspend RVSM within selected areas and/or altitudes due to adverse weather conditions, e.g. pilot reports greater-than-moderate turbulence. When RVSM is suspended, the vertical separation minimum between all aircraft will be 2 000 ft.

Pilots may be requested by ATC to confirm that they are approved for RVSM operations. Pilots/operators unable to provide such confirmation will be issued a clearance to operate outside RVSM airspace:

PHRASEOLOGY:

“Affirm RVSM” or “Negative RVSM (supplementary information, e.g. monitoring flight).” See phraseology depicted in Figure 12.4

11.7.4 In-Flight Procedures

Before entering RVSM airspace, the status of required equipment should be reviewed. The following equipment should be operating normally:

- (a) two independent altitude measurement systems;
- (b) one automatic altitude control system; and
- (c) one altitude alert system.

The pilot must notify ATC whenever the aircraft:

- (a) is no longer RVSM-compliant due to equipment failure;
- (b) experiences loss of redundancy of altimetry systems; or
- (c) encounters turbulence or mountain wave activity that affects the capability to maintain the cleared flight level.

In the event that any of the required equipment fails prior to entering RVSM airspace, a new clearance should be requested in order to avoid RVSM airspace.

In level cruise, it is essential that the aircraft maintains the cleared flight level. Except in contingency situations, aircraft should not deviate from the cleared flight level without an ATC clearance. If the pilot is notified by ATC of an assigned altitude deviation (AAD) error of 300 ft or greater, the pilot should return to the cleared flight level as soon as possible.

TRANSITION BETWEEN FLs: During cleared transition between flight levels, the aircraft should not overshoot or undershoot the assigned level by more than 150 ft.

11.7.5 Flight Planning Requirements

Unless an aircraft can be accommodated in RVSM airspace as detailed in paragraph 12.17.6, RVSM approval is required for the aircraft to operate within RVSM airspace. The operator must determine that the aircraft has been approved by the appropriate State authority and will meet the RVSM requirements for the filed route of flight and any planned alternate routes. The letter “W” shall be inserted in Item 10 (Equipment) of the flight plan to indicate that the aircraft is RVSM-compliant and the operator is RVSM-approved. The “W” designator is not to be used unless both conditions are met. If the aircraft registration is not used in Item 7, the registration is to be entered in Item 18 (RAC 3.16.8 “REG/”).

ATC will use the equipment block information to either issue or deny clearance into RVSM airspace and to apply either 1 000 ft or 2 000 ft vertical separation minimum.

Non-RVSM aircraft requesting permission to operate in RVSM airspace shall include “STS/NONRVSM” in Item 18 of the flight plan to indicate the reason for special handling by ATS.

11.7.6 Operation of Non-Reduced Vertical Separation Minimum (Non-RVSM) Aircraft in RVSM Airspace

FLIGHT PRIORITY: RVSM aircraft will be given priority for level allocation over non-RVSM aircraft. Non-RVSM aircraft may be accommodated on a traffic- and workload-permitting basis.

VERTICAL SEPARATION: The vertical separation minimum between non-RVSM aircraft operating in RVSM airspace and all other aircraft is 2 000 ft.

CONTINUOUS CLIMB OR DESCENT THROUGH RVSM AIRSPACE: Non-RVSM aircraft may be cleared to climb to and operate above FL 410 or descend to and operate below FL 290, provided the aircraft is capable of:

- (a) a continuous climb or descent and does not need to level off at an intermediate altitude for any operational considerations; and
- (b) climb or descent at the normal rate for the aircraft.

STATE AIRCRAFT: For the purposes of RVSM operations, State aircraft are those aircraft used in military, customs and police services.

- (a) State aircraft are exempt from the requirement to be RVSM-approved to operate in RVSM airspace.

NON-RVSM AIRCRAFT IN RVSM AIRSPACE: Non-RVSM aircraft may flight plan to operate within RVSM airspace, provided the aircraft:

- (a) is being delivered to the State of Registry or Operator;
- (b) was formerly RVSM-approved, but has experienced an equipment failure and is being flown to a maintenance facility for repair in order to meet RVSM requirements and/or obtain approval;
- (c) is being utilized for mercy or humanitarian purposes;
- (d) is a photographic survey flight (CDA only). This approval is not applicable for that portion of flight transiting to and from the area(s) of surveying or mapping operations;
- (e) is conducting flight checks of a NAVAID. This approval is not applicable for that portion of flight transiting to and from the area(s) of flight check operations; or
- (f) is conducting a monitoring, certification or developmental flight.

PHRASEOLOGY: Pilots of non-RVSM flights should include the phraseology “negative RVSM” in all initial calls on ATC frequencies, requests for flight level changes, readbacks of flight level clearances within RVSM airspace and readbacks of climb or descent clearances through RVSM airspace. See Figure 12.4.

11.7.7 Delivery Flights for Aircraft that are Reduced Vertical Separation Minimum (RVSM)-Compliant on Delivery

An aircraft that is RVSM-compliant on delivery may operate in Canadian Domestic RVSM airspace provided that the crew is trained on RVSM policies and procedures applicable in the airspace and the responsible State issues the operator a letter of authorization approving the operation.

State notification to the NAARMO should be in the form of a letter, e-mail or fax documenting the one-time flight indicating:

- (a) planned date of the flight;
- (b) flight identification;
- (c) registration number; and
- (d) aircraft type/series.

11.7.8 Airworthiness and Operational Approval and Monitoring

Operators must obtain airworthiness and operational approval from the State of Registry or State of the Operator, as appropriate, to conduct RVSM operations. For the purposes of RVSM, the following terminology has been adopted:

- (a) **RVSM Airworthiness Approval:** The approval that is issued by the appropriate State authority to indicate that an aircraft has been modified in accordance with the relevant approval documentation, e.g. service bulletin, supplemental type certificate, and is therefore eligible for monitoring. The date of issue of such an approval should coincide with the date when the modification was certified by the operator as being complete.
- (b) **RVSM (Operational) Approval:** The approval that is issued by the appropriate State authority once an operator has achieved the following:
 - (i) RVSM airworthiness approval; and
 - (ii) State approval of Operations Manual (where applicable) and on-going maintenance procedures.

Operators of Canadian-registered aircraft intending to operate in RVSM airspace will be required to show that they meet all the applicable standards in accordance with CARs Parts VI and VII. Information on RVSM approval may be obtained from:

Airworthiness Approvals:

Transport Canada
 Safety and Security Director,
 Aircraft Certification (AARD)
 Ottawa ON K2G 5X4
 Tel:1-800-305-2059
 Fax:613-996-9178

Operating Standards Commercial Air Carriers and Private Operators:

Transport Canada Safety and Security,
 Commercial and Business Aviation (AARTF)
 Ottawa ON K1A 0N8
 Tel.: 1-800-305-2059
 Fax: 613-954-1602

RVSM Maintenance Programs: (AARTM)
 Transport Canada Safety and Security,
 Ottawa ON K1A 0N8
 Tel.: 1-800-305-2059
 Fax:613-952-3298

11.7.9 Monitoring

All operators that operate or intend to operate in airspace where RVSM is applied are required to participate in the RVSM monitoring program. Monitoring prior to the issuance of RVSM operational approval is not a requirement. However, operators should submit monitoring plans to the responsible civil aviation authority to show that they intend to meet the North American RVSM minimum monitoring requirements.

ADS-B and GPS-based monitoring systems are available to support RVSM operations. Monitoring is a quality control program that enables Transport Canada and other civil aviation authorities to assess the in-service altitude-keeping performance of aircraft and operators.

GPS monitoring unit (GMU) services to conduct a height-keeping performance monitoring flight may be obtained from the following agencies:

CSSI, Inc.
Washington, DC
Tel.:202-863-2175
E-mail:monitor@cssiinc.com
Web site:<https://www.cssiinc.com/reduced-vertical-separation-minimum-rvs>

ARINC
Annapolis, MD
RVSM Operations Coordinator
Tel.: 410-266-4707
E-mail:rvsmops@arinc.com
Web site: www.rockwellcollins.com

11.7.10 North American Approvals Registry and Monitoring Organization (NAARMO)

The Regional Monitoring Agency for CDA is the NAARMO, located in Atlantic City, NJ, and may be contacted as follows:

William J. Hughes Technical Center NAS & International
Airspace Analysis Branch (ACT-520)
Atlantic City International Airport Atlantic City, NJ
08405 USA
Fax:609-485-5117
AFTN: N/A

Information on the responsibilities and procedures applicable to the NAARMO may be found on the Web site:

<www.faa.gov/air_traffic/separation_standards/naarmo/>.

11.7.11 Traffic Alert and Collision Avoidance System (TCAS) II/Airborne Collision Avoidance System (ACAS) II Reduced Vertical Separation Minimum (RVSM) Requirements

Aeroplanes operating in accordance with CAR 702, 703, 704 and 705 in RVSM airspace must be equipped with TCAS II/ACAS II. The TCAS II/ACAS II must be TSO to TSO-C-119b or later revision (TCAS II software version 7.0). All other TCAS/ACAS-equipped aircraft operating in RVSM airspace should be equipped with software version 7.

11.7.12 Mountain Wave Activity (MWA)

Significant MWA occurs both below and above FL 290, which is the floor of RVSM airspace. It often occurs in western Canada and western USA in the vicinity of mountain ranges. It may occur when strong winds blow perpendicular to mountain ranges, resulting in up and down or wave motions in the atmosphere.

Wave action can produce altitude excursions and airspeed fluctuations accompanied by only light turbulence. With sufficient amplitude, however, wave action can induce altitude and airspeed fluctuations accompanied by severe turbulence. MWA is difficult to forecast and can be highly localized and short-lived.

Wave activity is not necessarily limited to the vicinity of mountain ranges. Pilots experiencing wave activity anywhere that significantly affects altitude-keeping can follow the guidance provided below.

In-flight indications that the aircraft is being subjected to MWA are:

- (a) altitude excursions and airspeed fluctuations with or without associated turbulence;
- (b) pitch and trim changes required to maintain altitude with accompanying airspeed fluctuations; and
- (c) light to severe turbulence depending on the magnitude of the MWA.

TCAS Sensitivity—For both MWA and greater-than-moderate turbulence encounters in RVSM airspace, an additional concern is the sensitivity of collision avoidance systems when one or both aircraft operating in close proximity receive TCAS advisories in response to disruptions in altitude hold capability.

Pre-flight tools—Sources of observed and forecast information that can help the pilot ascertain the possibility of MWA or severe turbulence are: Forecast Winds and Temperatures Aloft (FD), Area Forecast (FA), SIGMETs and PIREPS.

11.7.13 Wake Turbulence

Pilots should be aware of the potential for wake turbulence encounters following Southern Domestic RVSM (SDRVSM) implementation. Experience gained since 1997, however, has shown that such encounters in RVSM airspace are generally moderate or less in magnitude.

It is anticipated that, in SDRVSM airspace, wake turbulence experience will mirror European RVSM experience gained since January 2002. European authorities have found that reports of wake turbulence encounters had not increased significantly since RVSM implementation (eight versus seven reports in a ten-month period). In addition, they found that reported wake turbulence was generally similar to moderate clear air turbulence.

Pilots should be alert for wake turbulence when operating:

- (a) in the vicinity of aircraft climbing or descending through their altitude;
- (b) approximately 12–15 mi. after passing 1 000 ft below opposite direction traffic; and
- (c) approximately 12–15 mi. behind and 1 000 ft below same direction traffic.

Table 11.1—Pilot/Controller Standard Phraseology for RVSM Operations

Message	Phraseology
For a controller to ascertain the RVSM approval status of an aircraft	(call sign) confirm RVSM approved
Pilot indication that flight is RVSM-approved	Affirm RVSM
Pilot will report lack of RVSM approval (Non-RVSM status): a. On the initial call on any frequency in the RVSM airspace; and b. In all requests for flight level changes pertaining to flight levels within the RVSM airspace; and c. In all read-backs to flight level clearances pertaining to flight levels within the RVSM airspace; and d. In read-back of flight level clearances involving climb and descent through RVSM airspace (FL 290-410)	Negative RVSM (supplementary information, e.g. “monitoring flight”)
Pilot report of one of the following after entry into RVSM airspace: all primary altimeters, automatic altitude control systems or altitude alerters have failed (This phrase is to be used to convey both the initial indication of RVSM aircraft system failure and on initial contact on all frequencies in RVSM airspace until the problem ceases to exist or the aircraft has exited RVSM airspace)	Unable RVSM Due Equipment
ATC denial of clearance into RVSM airspace	Unable issue clearance into RVSM airspace, maintain FL__.
Pilot reporting inability to maintain cleared flight level due to weather encounters.	Unable RVSM due (state reason) (e.g. turbulence, mountain wave)
ATC requesting pilot to confirm that an aircraft has regained RVSM-approved status or a pilot is ready to resume RVSM	Confirm able to resume RVSM
Pilot ready to resume RVSM after aircraft system or weather contingency	Ready to resume RVSM

11.7.14 In-Flight Contingencies

The following general procedures are intended as guidance only. Although all possible contingencies cannot be covered, they provide for cases of inability to maintain assigned level due to:

- (a) weather;
- (b) aircraft performance; and
- (c) pressurization failure.

The pilot’s judgment should determine the sequence of actions to be taken, taking into account specific circumstances, and ATC shall render all possible assistance.

If an aircraft is unable to continue flight in accordance with its ATC clearance, a revised clearance shall, whenever possible, be obtained prior to initiating any action, using a distress or urgency signal if appropriate. If prior clearance cannot be obtained, an ATC clearance shall be obtained at the earliest possible time. The pilot should take the following actions until a revised ATC clearance is received:

- (a) establish communications with and alert nearby aircraft by broadcasting, at suitable intervals: flight identification, flight level, aircraft position, (including the ATS route designator or the track code) and intentions on the frequency in use, as well as on frequency 121.5 MHz (or, as a back-up, the inter-pilot air-to-air frequency 123.45 MHz);
- (b) initiate such action as necessary to ensure safety. If the pilot determines that there is another aircraft at or near the same flight level, which might conflict, the pilot is expected to adjust the path of the aircraft, as necessary, to avoid conflict.

Figure 12.5 provides pilot guidance on actions to take under certain conditions of aircraft system failure and weather encounters. It also describes the ATC controller actions in these situations. It is recognized that the pilot and controller will use judgement to determine the action most appropriate to any given situation.

Table 11.2(a)—Contingency Pilot Actions: Initial Actions

Initial pilot actions when unable to maintain flight level or unsure of aircraft altitude-keeping capability
<ul style="list-style-type: none"> • Notify ATC and request assistance as detailed below; • Maintain cleared flight level, if possible, while evaluating the situation; • Watch for conflicting traffic, both visually and with reference to ACAS/TCAS, if equipped; and • Alert nearby aircraft by illuminating exterior lights, broadcasting position, flight level and intentions on 121.5 MHz (or as back-up, the inter-pilot air-to-air frequency, 123.45 MHz).

Table 11.2(b)—Contingency Pilot Actions: Inability to Maintain Cleared Flight Level Due to Weather

Pilot should:	ATC may be expected to:
<ul style="list-style-type: none"> Contact ATC and advise “Unable RVSM Due (state reason)” (e.g. turbulence, mountain wave) 	<ul style="list-style-type: none"> In ATS surveillance airspace, where 1 000 ft vertical separation exists between two aircraft, and targets appear likely to merge, vector one or both aircraft to establish ATS surveillance separation until the pilot reports clear of the turbulence
<ul style="list-style-type: none"> If not initiated by the controller, and if in ATS surveillance airspace, request vector clear of traffic at adjacent flight levels 	<ul style="list-style-type: none"> Provide lateral or longitudinal separation from traffic at adjacent flight levels, traffic-permitting
<ul style="list-style-type: none"> Request flight level change or re-route, if desired 	<ul style="list-style-type: none"> Advise pilot of conflicting traffic
	<ul style="list-style-type: none"> Issue flight level change or re-route, traffic-permitting

Table 11.2(c)—Contingency Pilot Actions: Report of Mountain Wave Activity

Pilot should:	ATC may be expected to:
<ul style="list-style-type: none"> Contact ATC and report experiencing MWA 	<ul style="list-style-type: none"> Advise pilot of conflicting traffic
<ul style="list-style-type: none"> If advised of conflicting traffic at adjacent flight levels and the aircraft is experiencing MWA that significantly affects altitude-keeping, request vector to acquire horizontal separation If so desired, request a flight level change or re-route 	<ul style="list-style-type: none"> If pilot requests, vector aircraft to achieve horizontal separation, traffic-permitting In ATS surveillance airspace, where 1 000 ft vertical separation exists between two aircraft, and targets appear likely to merge, vector one or both aircraft to establish ATS surveillance separation until the pilot reports clear of MWA Issue flight level change or re-route, traffic-permitting
<ul style="list-style-type: none"> Report location and magnitude of MWA to ATC 	<ul style="list-style-type: none"> Issue PIREP to other aircraft concerned

Table 11.2(d)—Contingency Pilot Actions: Wake Turbulence Encounter

Pilot should:	ATC may be expected to:
<ul style="list-style-type: none"> Contact ATC and request vector lateral offset or flight level change 	<ul style="list-style-type: none"> Issue vector, lateral offset or flight level change, traffic-permitting

Table 11.2(e)—Contingency Pilot Actions: Failure of Automatic Altitude Control System, Altitude Alserter or All Primary Altimeters

Pilot will:	ATC will:
<ul style="list-style-type: none"> Contact ATC and advise “Unable RVSM Due Equipment” Request Clearance out of RVSM unless operational situation dictates otherwise 	<ul style="list-style-type: none"> Provide 2 000 ft vertical separation or appropriate horizontal separation Clear aircraft out of RVSM airspace

Table 11.2(f)—Contingency Pilot Actions: One Operational Primary Altimeter

Pilot will:	ATC will:
<ul style="list-style-type: none"> Cross-check stand-by altimeter Notify ATC of loss of redundancy, operation with single primary altimeter If unable to confirm primary altimeter accuracy, follow action for failure of all primary altimeters 	<ul style="list-style-type: none"> Acknowledge operation with single primary altimeter and monitor progress

11.8 Minimum Safe Altitude Warning (MSAW)

11.8.1 General

Minimum safe altitude warning (MSAW) is an ATS surveillance display feature designed to alert controllers to the existence of aircraft operating or predicted to operate at altitudes where separation from terrain cannot be assured. It is used to assist controllers in detecting altitude deviations that could result in controlled flight into terrain (CFIT).

MSAW service is only available in the Vancouver FIR to IFR and CVFR aircraft operating in en route controlled airspace that receive ATS surveillance service and are in direct communication with the controller. There is a service exclusion zone within a 100-NM radius of CYVR. In addition, MSAW service is not available in control zones and approach/ departure corridors.

11.8.2 Procedures

In the event an MSAW is generated, the controller will provide the following information:

- (a) TERRAIN WARNING
- (b) IMMEDIATE SAFE ALTITUDE [VALUE]
- (c) ALTIMETER [VALUE]

11.8.3 Pilot-Initiated Terrain Avoidance Procedure

If the aircraft is equipped with GPWS or TAWS, the flight crew is expected to carry out the appropriate terrain avoidance procedures in response to an on-board alarm. The pilot of a GPWS/TAWS-equipped aircraft should acknowledge receipt of the altimeter and immediate safe altitude information from the controller. The pilot should also advise the controller of the terrain avoidance action being taken when beginning the manoeuvre or as soon as workload permits.

Example:

*Pilot: ROGER, INITIATING GPWS/TAWS CLIMB or
ROGER, GPWS/TAWS EQUIPPED*

The controller at this point will provide the aircraft with additional terrain-related information, as appropriate.

Example:

*ATC: [higher/lower] TERRAIN AHEAD, TO YOUR
[left/right]
IMMEDIATE SAFE ALTITUDE NOW [altitude]*

11.8.4 Air Traffic Control (ATC)-Initiated Terrain Avoidance Procedure

After issuing the altimeter and immediate safe altitude information the controller will, if appropriate, provide direction based on the MSAW information received.

Example:

ATC: EXPEDITE CLIMB TO SEVEN THOUSAND

In the event that the aircraft is not GPWS/TAWS-equipped or the pilot has not yet received a warning from his/her on-board system, the pilot should request vectors for terrain avoidance assistance as required.

Example:

*Pilot: REQUEST VECTORS FOR TERRAIN
AVOIDANCE or REQUEST TERRAIN
AVOIDANCE INSTRUCTION*

Although the prime responsibility to initiate terrain avoidance rests with the pilot, if, in the judgment of the controller, it becomes apparent that the aircraft is in danger of colliding with terrain, the controller may initiate terrain avoidance intervention.

Example:

*ATC: TURN [left/right] [number of] DEGREES
IMMEDIATELY or CLIMB [altitude]
IMMEDIATELY*

Once terrain avoidance has been initiated, the pilot will be provided with all additional terrain-related information available.

Example:

*ATC: [higher/lower] TERRAIN AHEAD, TO YOUR
[left/right] IMMEDIATE SAFE ALTITUDE NOW
[value]*

If, at any time during the procedure, the pilot regains sight of the terrain, visual terrain avoidance should resume and the controller should be advised as soon as practicable.

11.8.5 Assistance to Aircraft in Distress

The digitized terrain contour map component of the MSAW system can be used by the controller independently of the warning function to provide navigational assistance to any aircraft in need. Such aircraft could include identified aircraft that are lost or have encountered icing in mountainous terrain.

Vectoring for terrain avoidance can be provided to aircraft in distress or experiencing an emergency, provided the pilot requests it or the controller suggests it and the pilot concurs.

11.9 Formation Flights

(See AIP Canada ENR paragraph 5.5.1.)

12.0 RAC Annex

12.1 General

This annex contains those *Canadian Aviation Regulations (CARs)* that relate to the subject matter of this chapter, but may not have been incorporated, in full or in part, in the chapter text.

12.2 *Canadian Aviation Regulations (CARs)*

Reckless or Negligent Operation of Aircraft

602.01

No person shall operate an aircraft in such a reckless or negligent manner as to endanger or be likely to endanger the life or property of any person.

Fitness of Flight Crew Members

602.02

An operator of an aircraft shall not require any person to act as a flight crew member or to carry out a preflight duty, and a person shall not act as a flight crew member or carry out that duty, if the operator or the person has reason to believe that the person is not, or is not likely to be, fit for duty.

Alcohol or Drugs – Crew Members

602.03

No person shall act as a crew member of an aircraft

- (a) within 12 hours after consuming an alcoholic beverage;
- (b) while under the influence of alcohol; or
- (c) while using any drug that impairs the person's faculties to the extent that the safety of the aircraft or of persons on board the aircraft is endangered in any way.

Alcohol or Drugs – Passengers

602.04

- (1) In this Section, "intoxicating liquor" means a beverage that contains more than 2.5 percent proof spirits.
- (2) No person shall consume on board an aircraft an intoxicating liquor unless the intoxicating liquor
 - (a) has been served to that person by the operator of the aircraft;
 - (b) where no flight attendant is on board, has been provided by the operator of the aircraft.
- (3) No operator of an aircraft shall provide or serve any intoxicating liquor to a person on board the aircraft, where there are reasonable grounds to believe that the person's faculties are impaired by alcohol or a drug to an extent that may present a hazard to the aircraft or to persons on board the aircraft.
- (4) Subject to subsection (5), no operator of an aircraft shall allow a person to board the aircraft, where there are reasonable grounds to believe that the person's faculties are

impaired by alcohol or a drug to an extent that may present a hazard to the aircraft or to persons on board the aircraft.

- (5) The operator of an aircraft may allow a person whose faculties are impaired by a drug to board an aircraft, where the drug was administered in accordance with a medical authorization and the person is under the supervision of an attendant.

Compliance with Instructions

602.05

- (1) Every passenger on board an aircraft shall comply with instructions given by any crew member respecting the safety of the aircraft or of persons on board the aircraft.
- (2) Every crew member on board an aircraft shall, during flight time, comply with the instructions of the pilot-in-command or of any person whom the pilot-in-command has authorized to act on behalf of the pilot-in-command.

Smoking

602.06

- (1) No person shall smoke on board an aircraft during takeoff or landing or when directed not to smoke by the pilot-in-command.
- (2) No person shall smoke in an aircraft lavatory.
- (3) No person shall tamper with or disable a smoke detector installed in an aircraft lavatory without permission from a crew member or the operator of the aircraft.

Aircraft Operating Limitations

602.07

No person shall operate an aircraft unless it is operated in accordance with the operating limitations

- (a) set out in the aircraft flight manual, where an aircraft flight manual is required by the applicable standards of airworthiness;
- (b) set out in a document other than the aircraft flight manual, where use of that document is authorized pursuant to Part VII;
- (c) indicated by markings or placards required pursuant to Section 605.05; or
- (d) prescribed by the competent authority of the state of registry of the aircraft.

Portable Electronic Devices

602.08

- (1) No operator of an aircraft shall permit the use of a portable electronic device on board an aircraft, where the device may impair the functioning of the aircraft's systems or equipment.
- (2) No person shall use a portable electronic device on board an aircraft except with the permission of the operator of the aircraft.

Carry-on Baggage, Equipment and Cargo**602.86**

- (1) No person shall operate an aircraft with carry-on baggage, equipment or cargo on board, unless the carry-on baggage, equipment and cargo are
 - (a) stowed in a bin, compartment, rack or other location that is certified in accordance with the aircraft type certificate in respect of the stowage of carry-on baggage, equipment or cargo; or
 - (b) restrained so as to prevent them from shifting during movement of the aircraft on the surface and during takeoff, landing and in-flight turbulence.
- (2) No person shall operate an aircraft with carry-on baggage, equipment or cargo on board unless
 - (a) the safety equipment, the normal and emergency exits that are accessible to passengers and the aisles between the flight deck and a passenger compartment are not wholly or partially blocked by carry-on baggage, equipment or cargo;
 - (b) all of the equipment and cargo that are stowed in a passenger compartment are packaged or covered to avoid possible injury to persons on board;
 - (c) where the aircraft is type-certificated to carry 10 or more passengers and passengers are carried on board,
 - (i) no passenger's view of any "seat belt" sign, "no smoking" sign or exit sign is obscured by carry-on baggage, equipment or cargo except if an auxiliary sign is visible to the passenger or another means of notification of the passenger is available,
 - (ii) all of the passenger service carts and trolleys are securely restrained during movement of the aircraft on the surface, takeoff and landing, and during in-flight turbulence where the pilot-in-command or in-charge flight attendant has directed that the cabin be secured pursuant to subsection 605.25(3) or (4), and
 - (iii) all of the video monitors that are suspended from the ceiling of the aircraft and extend into an aisle are stowed and securely restrained during takeoff and landing; and
 - (d) all of the cargo that is stowed in a compartment to which crew members have access is stowed in such a manner as to allow a crew member to effectively reach all parts of the compartment with a hand-held fire extinguisher.

Crew Member Instructions**602.87**

The pilot-in-command of an aircraft shall ensure that each crew member, before acting as a crew member on board the aircraft, has been instructed with respect to

- (a) the duties that the crew member is to perform; and
- (b) the location and use of all of the normal and emergency exits and of all of the emergency equipment that is carried on board the aircraft.

Passenger Briefings**602.89**

- (1) The pilot-in-command of an aircraft shall ensure that all of the passengers on board the aircraft are briefed before takeoff with respect to the following, where applicable:
 - (a) the location and means of operation of emergency and normal exits;
 - (b) the location and means of operation of safety belts, shoulder harnesses and restraint devices;
 - (c) the positioning of seats and the securing of seat backs and chair tables;
 - (d) the stowage of carry-on baggage;
 - (e) where the aircraft is unpressurized and it is possible that the flight will require the use of oxygen by the passengers, the location and means of operation of oxygen equipment; and
 - (f) any prohibition against smoking.
- (2) The pilot-in-command of an aircraft shall ensure that all of the passengers on board the aircraft are briefed
 - (a) in the case of an over-water flight where the carriage of life preservers, individual flotation devices or personal flotation devices is required pursuant to Section 602.62, before commencement of the over-water portion of the flight, with respect to the location and use of those items; and
 - (b) in the case of a pressurized aircraft that is to be operated at an altitude above FL 250, before the aircraft reaches FL 250, with respect to the location and means of operation of oxygen equipment.
- (3) The pilot-in-command of an aircraft shall, before takeoff, ensure that all of the passengers on board the aircraft are provided with information respecting the location and use of
 - (a) first aid kits and survival equipment;
 - (b) where the aircraft is a helicopter or a small aircraft that is an aeroplane, any ELT that is required to be carried on board pursuant to Section 605.38; and
 - (c) any life raft that is required to be carried on board pursuant to Section 602.63.

Noise Operating Criteria**602.105**

No person shall operate an aircraft at or in the vicinity of an aerodrome except in accordance with the applicable noise abatement procedures and noise control requirements specified by the Minister in the *Canada Air Pilot* or *Canada Flight Supplement*, including the procedures and requirements relating to

- (a) preferential runways;
- (b) minimum noise routes;
- (c) hours when aircraft operations are prohibited or restricted;
- (d) arrival procedures;
- (e) departure procedures;
- (f) duration of flights;
- (g) the prohibition or restriction of training flights;
- (h) VFR or visual approaches;
- (i) simulated approach procedures; and
- (j) the minimum altitude for the operation of aircraft in the vicinity of the aerodrome.

Noise-Restricted Runways**602.106**

- (1) Subject to subsection (2), no person shall operate a subsonic turbo-jet aeroplane that has a maximum certificated take-off weight of more than 34 000 kg (74,956 pounds) on take-off at a noise-restricted runway set out in column II of an item of the table to this section at an aerodrome set out in column I of that item, unless there is on board
 - (a) a certificate of airworthiness indicating that the aeroplane meets the applicable noise emission standards;
 - (b) a certificate of noise compliance issued in respect of the aeroplane; or
 - (c) where the aeroplane is not a Canadian aircraft, a document issued by the state of registry that specifies that the aeroplane meets the applicable noise emission requirements of that state.
- (2) Subsection (1) does not apply
 - (a) to the extent that it is inconsistent with any obligation assumed by Canada in respect of a foreign state in a treaty, convention or agreement;
 - (b) where the pilot-in-command of an aircraft has declared an emergency; or
 - (c) where an aircraft is operated on
 - (i) an air evacuation operation,
 - (ii) any other emergency air operation, or
 - (iii) a departure from an aerodrome at which it was required to land because of an emergency.

Table 1 RAC Annex—Noise Restricted Runways for Takeoff

Item	Column I	Column II
	Aerodrome	Noise Restricted Runways for Takeoff
1.	Vancouver International Airport	08L, 08R, 12, 26R
2.	Calgary International Airport	07, 10, 16, 25, 28
3.	Edmonton City Centre (Blatchford Field) Airport	All runways
4.	Edmonton International Airport	12
5.	Winnipeg/James Armstrong Richardson International Airport	13, 18
6.	Hamilton Airport	06
7.	Toronto/Lester B. Pearson International Airport	05, 06L, 06R, 15L, 15R
8.	Ottawa/Macdonald-Cartier International Airport	32
9.	Montréal/Pierre Elliott Trudeau International Airport	All runways

Power-driven Aircraft – day VFR**605.14**

No person shall conduct a takeoff in a power-driven aircraft for the purpose of day VFR flight unless it is equipped with

- (a) where the aircraft is operated in uncontrolled airspace, an altimeter;
- (b) where the aircraft is operated in controlled airspace, a sensitive altimeter adjustable for barometric pressure;
- (c) an airspeed indicator;
- (d) a magnetic compass or a magnetic direction indicator that operates independently of the aircraft electrical generating system;
- (e) a tachometer for each engine and for each propeller or rotor that has limiting speeds established by the manufacturer;
- (f) an oil pressure indicator for each engine employing an oil pressure system;
- (g) a coolant temperature indicator for each liquid-cooled engine;
- (h) an oil temperature indicator for each air-cooled engine having a separate oil system;
- (i) a manifold pressure gauge for each
 - (i) reciprocating engine equipped with a variable-pitch propeller,
 - (ii) reciprocating engine used to power a helicopter,
 - (iii) supercharged engine, and
 - (iv) turbocharged engine;

- (j) a means for the flight crew, when seated at the flight controls to determine
 - (i) the fuel quantity in each main fuel tank, and
 - (ii) if the aircraft employs retractable landing gear, the position of the landing gear;
- (k) subject to subsections 601.08(2) and 601.09(2), a radiocommunication system adequate to permit two-way communication on the appropriate frequency when the aircraft is operated within
 - (i) Class B, Class C or Class D airspace,
 - (ii) an MF area, unless the aircraft is operated pursuant to subsection 602.97(3), or
 - (iii) the ADIZ;
- (l) where the aircraft is operated under Subpart 4 of this Part, or under Subpart 3, 4 or 5 of Part VII, radiocommunication equipment adequate to permit two-way communication on the appropriate frequency;
- (m) where the aircraft is operated in Class B airspace, radio navigation equipment that will enable it to be operated in accordance with a flight plan; and
- (n) where the aircraft is operated under Subpart 4 of this Part or under Subpart 5 of Part VII, radio navigation equipment that is adequate to receive radio signals from a transmitting facility.

Power-driven Aircraft – VFR OTT

605.15

- (1) No person shall conduct a takeoff in a power-driven aircraft for the purpose of VFR OTT flight unless it is equipped with
 - (a) the equipment referred to in paragraphs 605.14(c) to (j);
 - (b) a sensitive altimeter adjustable for barometric pressure;
 - (c) a means of preventing malfunction caused by icing for each airspeed indicating system;
 - (d) a gyroscopic direction indicator or a stabilized magnetic direction indicator;
 - (e) an attitude indicator;
 - (f) subject to subsection (2), a turn and slip indicator or turn coordinator;
 - (g) where the aircraft is to be operated within the Northern Domestic Airspace, a means of establishing direction that is not dependent on a magnetic source;
 - (h) radiocommunication equipment adequate to permit two-way communication on the appropriate frequency; and
 - (i) radio navigation equipment adequate to permit the aircraft to be navigated safely.
- (2) Where the aircraft is equipped with a third attitude indicator that is usable through flight attitudes of 360° of pitch and roll for an aeroplane, or ± 80° of pitch and ± 120° of roll for a helicopter, the aircraft may be equipped with a slip-skid indicator in lieu of a turn and slip indicator or turn coordinator.

Power-driven Aircraft – Night VFR

605.16

- (1) No person shall conduct a takeoff in a power-driven aircraft for the purpose of night VFR flight, unless it is equipped with
 - (a) the equipment referred to in paragraphs 605.14(c) to (n);
 - (b) a sensitive altimeter adjustable for barometric pressure;
 - (c) subject to subsection (2), a turn and slip indicator or turn coordinator;
 - (d) an adequate source of electrical energy for all of the electrical and radio equipment;
 - (e) in respect of every set of fuses of a particular rating that is installed on the aircraft and accessible to the pilot-in-command during flight, a number of spare fuses that is equal to at least 50 percent of the total number of installed fuses of that rating;
 - (f) where the aircraft is operated so that an aerodrome is not visible from the aircraft, a stabilized magnetic direction indicator or a gyroscopic direction indicator;
 - (g) where the aircraft is to be operated within the Northern Domestic Airspace, a means of establishing direction that is not dependent on a magnetic source;
 - (h) where the aircraft is an airship operated within controlled airspace, radar reflectors attached in such a manner as to be capable of a 360-degree reflection;
 - (i) a means of illumination for all of the instruments used to operate the aircraft;
 - (j) when carrying passengers, a landing light; and
 - (k) position and anti-collision lights that conform to the Aircraft Equipment and Maintenance Standards.
- (2) Where the aircraft is equipped with a third attitude indicator that is usable through flight attitudes of 360° of pitch and roll for an aeroplane, or ± 80° of pitch and ± 120° of roll for a helicopter, the aircraft may be equipped with a slip-skid indicator in lieu of a turn and slip indicator or turn coordinator.
- (3) No person shall operate an aircraft that is equipped with any light that may be mistaken for, or downgrade the conspicuity of, a light in the navigation light system, unless the aircraft is being operated for the purpose of aerial advertising.
- (4) In addition to the equipment requirements specified in subsection (1), no person shall operate an aircraft in night VFR flight under Subpart 4 of this Part or Subparts 2 to 5 of Part VII, unless the aircraft is equipped with
 - (a) an attitude indicator;
 - (b) a vertical speed indicator;
 - (c) a means of preventing malfunction caused by icing for each airspeed indicating system; and
 - (d) an outside air temperature gauge.

Use of Position and Anti-collision Lights**605.17**

- (1) Subject to subsection (2), no person shall operate an aircraft in the air or on the ground at night, or on water between sunset and sunrise, unless the aircraft position lights and anti-collision lights are turned on.
- (2) Anti-collision lights may be turned off where the pilot-in-command determines that, because of operating conditions, doing so would be in the interests of aviation safety.

Power-driven Aircraft – IFR**605.18**

No person shall conduct a takeoff in a power-driven aircraft for the purpose of IFR flight unless it is equipped with

- (a) when it is operated by day, the equipment required pursuant to paragraphs 605.16(1)(a) to (h);
- (b) when it is operated by night, the equipment required pursuant to paragraphs 605.16(1)(a) to (k);
- (c) an attitude indicator;
- (d) a vertical speed indicator;
- (e) an outside air temperature gauge;
- (f) a means of preventing malfunction caused by icing for each airspeed indicating system;
- (g) a power failure warning device or vacuum indicator that shows the power available to gyroscopic instruments from each power source;
- (h) an alternative source of static pressure for the altimeter, airspeed indicator and vertical speed indicator;
- (i) sufficient radiocommunication equipment to permit the pilot to conduct two-way communications on the appropriate frequency; and
- (j) sufficient radio navigation equipment to permit the pilot, in the event of the failure at any stage of the flight of any Item of that equipment, including any associated flight instrument display,
 - (i) to proceed to the destination aerodrome or proceed to another aerodrome that is suitable for landing, and
 - (ii) where the aircraft is operated in IMC, to complete an instrument approach and, if necessary, conduct a missed approach procedure.

Balloons – Day VFR**605.19**

No person shall conduct a takeoff in a balloon for the purpose of day VFR flight unless it is equipped with

- (a) an altimeter;
- (b) a vertical speed indicator;
- (c) in the case of a hot air balloon,
 - (i) a fuel quantity gauge, and
 - (ii) an envelope temperature indicator;
- (d) in the case of a captive gas balloon, a magnetic direction indicator; and
- (e) subject to subsections 601.08(2) and 601.09(2), a radio communication system adequate to permit two-way communication on the appropriate frequency when the balloon is operated within
 - (i) Class C or Class D airspace,
 - (ii) an MF area, unless the aircraft is operated pursuant to subsection 602.97(3), or
 - (iii) the ADIZ.

Balloons – Night VFR**605.20**

No person shall conduct a takeoff in a balloon for the purpose of night VFR flight unless it is equipped with

- (a) equipment required pursuant to Section 605.19;
- (b) position lights;
- (c) a means of illuminating all of the instruments used by the flight crew, including a flashlight; and
- (d) in the case of a hot air balloon, two independent fuel systems.

Gliders – Day VFR**605.21**

No person shall operate a glider in day VFR flight unless it is equipped with

- (a) an altimeter;
- (b) an airspeed indicator;
- (c) a magnetic compass or a magnetic direction indicator; and
- (d) subject to subsections 601.08(2) and 601.09(2), a radiocommunication system adequate to permit two-way communication on the appropriate frequency when the glider is operated within
 - (i) Class C or Class D airspace,
 - (ii) an MF area, unless the aircraft is operated pursuant to subsection 602.97(3), or
 - (iii) the ADIZ.

Seat and Safety Belt Requirements**605.22**

- (1) Subject to subsection 605.23, no person shall operate an aircraft other than a balloon unless it is equipped with a seat and safety belt for each person on board the aircraft other than an infant.
- (2) Subsection (1) does not apply to a person operating an aircraft that was type-certificated with a safety belt designed for two persons.
- (3) A safety belt referred to in subsection (1) shall include a latching device of the metal-to-metal type.

Restraint System Requirements**605.23**

An aircraft may be operated without being equipped in accordance with Section 605.22 in respect of the following persons if a restraint system that is secured to the primary structure of the aircraft is provided for each person who is

- (a) carried on a stretcher or in an incubator or other similar device;
- (b) carried for the purpose of parachuting from the aircraft; or
- (c) required to work in the vicinity of an opening in the aircraft structure.

Shoulder Harness Requirements**605.24**

- (1) No person shall operate an aeroplane, other than a small aeroplane manufactured before July 18, 1978, unless each front seat or, if the aeroplane has a flight deck, each seat on the flight deck is equipped with a safety belt that includes a shoulder harness.
- (2) Except as provided in Section 705.75, no person shall operate a transport category aeroplane unless each flight attendant seat is equipped with a safety belt that includes a shoulder harness.
- (3) No person shall operate a small aeroplane manufactured after December 12, 1986, the initial type certificate of which provides for not more than nine passenger seats, excluding any pilot seats, unless each forward- or aft-facing seat is equipped with a safety belt that includes a shoulder harness.
- (4) No person shall operate a helicopter manufactured after September 16, 1992, the initial type certificate of which specifies that the helicopter is certified as belonging to the normal or transport category, unless each seat is equipped with a safety belt that includes a shoulder harness.
- (5) No person operating an aircraft shall conduct any of the following flight operations unless the aircraft is equipped with a seat and a safety belt that includes a shoulder harness for each person on board the aircraft:
 - (a) aerobatic manoeuvres;
 - (b) Class B, C or D external load operations conducted by a helicopter; and

- (c) aerial application, or aerial inspection other than flight inspection for the purpose of calibrating electronic navigation aids, conducted at altitudes below 500 feet AGL.

General Use of Safety Belts and Restraint Systems**605.25**

- (1) The pilot-in-command of an aircraft shall direct all of the persons on board the aircraft to fasten safety belts
 - (a) during movement of the aircraft on the surface;
 - (b) during takeoff and landing; and
 - (c) at any time during flight that the pilot-in-command considers it necessary that safety belts be fastened.
- (2) The directions referred to in subsection (1) also apply to the use of the following restraint systems:
 - (a) a child restraint system;
 - (b) a restraint system used by a person who is engaged in parachute descents; and
 - (c) a restraint system used by a person when working in the vicinity of an opening in the aircraft structure.
- (3) Where an aircraft crew includes flight attendants and the pilot-in-command anticipates that the level of turbulence will exceed light turbulence, the pilot-in-command shall immediately direct each flight attendant to
 - (a) discontinue duties relating to service;
 - (b) secure the cabin; and
 - (c) occupy a seat and fasten the safety belt provided.
- (4) Where an aircraft is experiencing turbulence and the in-charge flight attendant considers it necessary, the in-charge flight attendant shall
 - (a) direct all of the passengers to fasten their safety belts; and
 - (b) direct all flight attendants to discontinue duties relating to service, to secure the cabin, to occupy the assigned seats and to fasten the safety belts provided and to do so oneself.
- (5) Where the in-charge flight attendant has given directions in accordance with subsection (4), the in-charge flight attendant shall so inform the pilot-in-command.

Use of Passenger Safety Belts and Restraint Systems

605.26

- (1) Where the pilot-in-command or the in-charge flight attendant directs that safety belts be fastened, every passenger who is not an infant shall
 - (a) ensure that the passenger's safety belt or restraint system is properly adjusted and securely fastened;
 - (b) if responsible for an infant for which no child restraint system is provided, hold the infant securely in the passenger's arms; and
 - (c) if responsible for a person who is using a child restraint system, ensure that the person is properly secured.
- (2) No passenger shall be responsible for more than one infant.

Use of Crew Member Safety Belts

605.27

- (1) Subject to subsection (2), the crew members on an aircraft shall be seated at their stations with their safety belts fastened
 - (a) during takeoff and landing;
 - (b) at any time that the pilot-in-command directs; and
 - (c) in the case of crew members who are flight attendants, at any time that the in-charge flight attendant so directs pursuant to paragraph 605.25(4)(b).
- (2) Where the pilot-in-command directs that safety belts be fastened by illuminating the safety belt sign, a crew member is not required to comply with paragraph (1)(b)
 - (a) during movement of the aircraft on the surface or during flight, if the crew member is performing duties relating to the safety of the aircraft or of the passengers on board;
 - (b) where the aircraft is experiencing light turbulence, if the crew member is a flight attendant and is performing duties relating to the passengers on board; or
 - (c) if the crew member is occupying a crew rest facility during cruise flight and the restraint system for that facility is properly adjusted and securely fastened.
- (3) The pilot-in-command shall ensure that at least one pilot is seated at the flight controls with safety belt fastened during flight time.

(4) Child Restraint System

605.28

- (1) No operator of an aircraft shall permit the use of a child restraint system on board the aircraft unless
 - (a) the person using the child restraint system is accompanied by a parent or guardian who will attend to the safety of the person during the flight;
 - (b) the weight and height of the person using the child restraint system are within the range specified by the manufacturer;
 - (c) the child restraint system bears a legible label indicating the applicable design standards and date of manufacture;
 - (d) the child restraint system is properly secured by the safety belt of a forward-facing seat that is not located in an emergency exit row and does not block access to an aisle; and
 - (e) the tether strap is used according to the manufacturer's instructions or, where subsection (2) applies, secured so as not to pose a hazard to the person using the child restraint system or to any other person.
- (2) Where a seat incorporates design features to reduce occupant loads, such as the crushing or separation of certain components, and the seat is in compliance with the applicable design standards, no person shall use the tether strap on the child restraint system to secure the system.
- (3) Every passenger who is responsible for a person who is using a child restraint system on board an aircraft shall be
 - (a) seated in a seat adjacent to the seat to which the child restraint system is secured;
 - (b) familiar with the manufacturer's installation instructions for the child restraint system; and
 - (c) familiar with the method of securing the person in the child restraint system and of releasing the person from it.

Flight Control Locks

605.29

- No operator of an aircraft shall permit the use of a flight control lock in respect of the aircraft unless
- (a) the flight control lock is incapable of becoming engaged when the aircraft is being operated; and
 - (b) an unmistakable warning is provided to the person operating the aircraft whenever the flight control lock is engaged.

De-icing or Anti-icing Equipment

605.30

No person shall conduct a takeoff or continue a flight in an aircraft where icing conditions are reported to exist or are forecast to be encountered along the route of flight unless

- (a) the pilot-in-command determines that the aircraft is adequately equipped to operate in icing conditions in accordance with the standards of airworthiness under which the type certificate for that aircraft was issued; or
- (b) current weather reports or pilot reports indicate that icing conditions no longer exist.

Oxygen Equipment and Supply

605.31

- (1) No person shall operate an unpressurized aircraft unless it is equipped with sufficient oxygen dispensing units and oxygen supply to comply with the requirements set out in the table to this subsection.

Table 2 RAC Annex—Oxygen Requirements for Unpressurized Aircraft

Item	Column I	Column II
	Persons For Whom Oxygen Supply Must Be Available	Period Of Flight And Cabin-Pressure-Altitude
1.	All crew members and 10 percent of passengers and, in any case, no less than one passenger	Entire period of flight exceeding 30 minutes at cabin-pressure-altitudes above 10 000 feet ASL but not exceeding 13 000 feet ASL
2.	All persons on board the aircraft	(a) Entire period of flight at cabin-pressure-altitudes above 13 000 feet ASL (b) For aircraft operated in an air transport service under the conditions referred to in paragraph(a), a period of flight of not less than one hour.

- (2) No person shall operate a pressurized aircraft unless it is equipped with sufficient oxygen dispensing units and oxygen supply to provide, in the event of cabin pressurization failure at the most critical point during the flight, sufficient oxygen to continue the flight to an aerodrome suitable for landing while complying with the requirements of the table to this subsection.

Table 3 RAC Annex—Minimum Oxygen Requirements for Pressurized Aircraft Following Emergency Descent

Item	Column I	Column II
	Persons For Whom Oxygen Supply Must Be Available	Period Of Flight And Cabin-Pressure-Altitude
1.	All crew members and 10 percent of passengers and, in any case, no less than one passenger	(a) Entire period of flight exceeding 30 minutes at cabin-pressure-altitudes above 10 000 feet ASL but not exceeding 13 000 feet ASL (b) Entire period of flight at cabin-pressure-altitudes above 13 000 feet ASL (c) For aircraft operated in an air transport service under the conditions referred to in paragraph (a) or (b), a period of flight of not less than (i) 30 minutes (Note 2), and (ii) for flight crew members, two hours for aircraft the type certificate of which authorizes flight at altitudes exceeding FL 250 (Note 3)
2.	All passengers	(a) Entire period of flight at cabin-pressure-altitudes exceeding 13 000 feet ASL (b) For aircraft operated in an air transport service under the conditions referred to in paragraph (a), a period of flight of not less than 10 minutes

NOTES:

- 1. In determining the available supply, the cabin pressure altitude descent profile for the routes concerned must be taken into account.
- 2. The minimum supply is that quantity of oxygen necessary for a constant rate of descent from the aircraft’s maximum operating altitude authorized in the type certificate to 10 000 ft ASL in 10 minutes, followed by 20 minutes at 10 000 feet ASL.
- 3. The minimum supply is that quantity of oxygen necessary for a constant rate of descent from the aircraft’s maximum operating altitude authorized in the type certificate to 10 000 ft ASL in 10 minutes, followed by 110 minutes at 10 000 feet ASL.

Use of Oxygen

605.32

- (1) Where an aircraft is operated at cabin-pressure-altitudes above 10 000 ft ASL, but not exceeding 13 000 ft ASL, each crew member shall wear an oxygen mask and use supplemental oxygen for any part of the flight at those altitudes that is more than 30 min in duration.
- (2) Where an aircraft is operated at cabin-pressure-altitudes above 13 000 ft ASL, each person on board the aircraft shall wear an oxygen mask and use supplemental oxygen for the duration of the flight at those altitudes.
- (3) The pilot at the flight controls of an aircraft shall use an oxygen mask if
 - (a) the aircraft is not equipped with quick-donning oxygen masks and is operated at or above FL 250; or
 - (b) the aircraft is equipped with quick-donning oxygen masks and is operated above FL 410.

12.3 Transportation of Dangerous Goods (TDG) by Air

Dangerous goods refers to a product, substance or organism included by its nature or by the regulations in any of the classes listed in the schedule to the *Transportation of Dangerous Goods Act, 1992*. There are nine classes of dangerous goods:

- | | |
|----------|--|
| Class 1: | Explosives; |
| Class 2: | Gases; |
| Class 3: | Flammable liquids; |
| Class 4: | Flammable solids; substances liable to spontaneous combustion; substances that on contact with water emit flammable gases; |
| Class 5: | Oxidizing substances and organic peroxides; |
| Class 6: | Toxic and infectious substances; |
| Class 7: | Radioactive materials; |
| Class 8: | Corrosives; and |
| Class 9: | Miscellaneous products, substances or organisms. |

Dangerous goods must not be carried on board any Canadian-registered aircraft, or in any foreign aircraft when operated in Canada, unless in compliance with the *Transportation of Dangerous Goods Act, 1992* (TDG Act, 1992) and the *Transportation of Dangerous Goods Regulations* (TDG Regulations).

Sections 12.1 to 12.3 of the TDG Regulations regulate the domestic and international transport of dangerous goods by air, and adopt by reference the ICAO's *Technical Instructions for the Safe Transport of Dangerous Goods by Air* (ICAO TIs).

Sections 12.4 to 12.17 of the TDG Regulations provide alternative domestic provisions for dangerous goods in air transport, which address the unique characteristics of the Canadian aviation industry and geographical environment.

Anyone handling, offering for transport or transporting dangerous goods by aircraft in Canada must be trained and hold a valid training certificate in compliance with Part 6, Training, of the TDG Regulations or be in the presence and under the direct supervision of a person who is trained and who holds a TDG training certificate. A TDG training certificate expires 24 months after its date of issuance.

The *Canadian Aviation Regulations* require that air operators submit procedures for the transport of dangerous goods and corresponding training programs to TC for review and approval. TC published Advisory Circular (AC) 700-001—*Dangerous Goods Special Authorization* to assist air operators in the development of dangerous goods procedures and training programs. The AC is available on the Transport Canada Civil Aviation (TCCA) documentation Web site: <<https://tc.canada.ca/en/aviation/reference-centre/advisory-circulars/advisory-circular-ac-no-700-001>>.

NOTE:

Consultants may provide assistance in developing dangerous goods procedures and training programs; however, generic procedures and training programs must be amended to reflect air operators' activities.

An air operator may delegate some of its responsibilities to third parties; however, the air operator remains accountable. Therefore, an air operator is responsible for training employees (and third-party staff) as per the approved dangerous goods procedures and training program.

Canadian private operators may not be required to submit dangerous goods documentation to TC for review and approval under CAR 604. However, the ICAO TIs, referenced in the TDG Regulations, require that all operators establish and maintain a training program, regardless of whether they carry dangerous goods as cargo or not.

For additional information, visit the TDG Web site (<<https://tc.canada.ca/en/dangerous-goods/transportation-dangerous-goods-canada>>) or contact one of the following TDG regional offices:

Atlantic

Tel.: 1-866-814-1477

E-mail: TDG-TMDAtlantic@tc.gc.ca

Quebec

Tel.: 1-514-633-3400

E-mail: TMD-TDG.Quebec@tc.gc.ca

Ontario

Tel.: 1-416-973-1868

E-mail: TDG-TMDOntario@tc.gc.ca

Prairie and Northern

Tel.: 1-888-463-0521

E-mail: TDG-TMDPNR@tc.gc.ca

Pacific

Tel.: 1-604-666-2955

E-mail: TDGPacific-TMDPacifique@tc.gc.ca