



# AMA<sup>®</sup> RULEBOOK

*2026-2027*

Control Line  
Speed



**RULES GOVERNING MODEL AVIATION COMPETITION IN THE UNITED STATES**

# Amendment Listing

---

Amendment Topic	Publication Date	Description
Original Issue	1/1/2015	Publication of Competition Regulations
Enable use of opto-electronic timing for the official scoring of control line speed events	1/1/2015	Changes in Sections 10.4, 11, 12, and 19.5
Verification flights	1/1/2022	Change from MPH to Percent sections 20., 20.1 and 20.3
Event 306 change in finish requirements	1/1/2022	Allows any type finish section 2 Design
Event 306 wing and stab requirements	1/1/2022	Changes in specifications, Section 3
Event 306 flying lines	1/1/2022	Changes in Specifications, section 5

# Table of Contents

---

<b>For events 301, 302, 303, 304, 305, 306, 307, 308, 309 .....</b>	<b>1</b>
1. <i>Applicability</i> .....	1
2. <i>General</i> .....	1
3. <i>Entry Participation Requirements</i> .....	1
4. <i>Classification of Control Line Speed Models</i> .....	2
5. <i>Model Design and Construction</i> .....	3
6. <i>Engine Restrictions</i> .....	4
7. <i>Fuel</i> .....	7
8. <i>Control Line Specifications and Pull Test</i> .....	7
9. <i>Control Handle</i> .....	8
10. <i>Competition Flying</i> .....	8
11. <i>Timing of Flights</i> .....	9
12. <i>Scoring of flights</i> .....	10
13. <i>Official Flight</i> .....	11
14. <i>Number of Flights</i> .....	11
15. <i>Engine Starting Time</i> .....	11
16. <i>Definition of an Attempt</i> .....	11
17. <i>Distance of Timed Course</i> .....	12
18. <i>Timing Pole—Height Marker</i> .....	12
19. <i>1/2A Proto Speed, event 305</i> .....	13
20. <i>Records</i> .....	15
<b>.21 PROTO SPEED For event 306 .....</b>	<b>16</b>
1. <i>Objective</i> .....	16
2. <i>Design</i> .....	16

3. Airplane Specifications.....	17
4. Engine, Propeller and Fuel System.....	17
5. Flying Lines.....	17
6. Fuel.....	17
7. Distance of Timed Course.....	17
<b>.21 SPORT SPEED For event 307 .....</b>	<b>18</b>
1. Applicability.....	18
2. Engine Restrictions.....	18
3. Model Design and Construction.....	18
4. Propellers.....	18
5. Size, Construction, and Length of Control Lines.....	18
6. Flight Timing.....	19
7.....	19
8.....	19
9. Records.....	19
<b>FORMULA .40 SPEED for event 308.....</b>	<b>19</b>
1. Applicability.....	19
2. Formula 40 Description.....	19
3. Engine Restrictions.....	19
4. Formula 40 Model Design and Construction.....	19
5. Launching.....	20
6. Size, Construction, and Length of Control Lines.....	20
7. Formula 40.....	20
8. Flight elevation.....	20
9. Scoring of flights.....	20
10. Records.....	20

<b>ESTABLISHMENT OF LINE SIZES AND PULL TESTS IN CL SPEED.....</b>	<b>20</b>
<i>General .....</i>	<i>20</i>
<i>Line Sizes.....</i>	<i>21</i>
<i>Pull Tests .....</i>	<i>21</i>
<i>Implementation.....</i>	<i>21</i>
<b>ELECTRIC EVENTS.....</b>	<b>21</b>
<i>Definition .....</i>	<i>21</i>
<i>General Specifications .....</i>	<i>22</i>
<i>Class A Control Line Speed For event 334.....</i>	<i>22</i>
<i>Class B Control Line Speed For event 335.....</i>	<i>22</i>

### 1. Applicability

All pertinent AMA regulations (see sections titled Sanctioned Competition, Records, Selection of Champions, and General) and the General Control Line rules shall apply, except as specified below.

### 2. General

A Control Line Speed model is a model airplane powered by internal combustion reciprocating or jet engine(s). A Jet Speed model obtains its forward motion entirely from the reaction caused by the exhaust gases of its internal combustion engine(s). Rockets are excluded. Supercharging or turbo-charging, whether it be engine driven or by gaseous boosts of any type shall also be prohibited. Only naturally aspirated engines shall be allowed in the Speed events.

#### 2.1.

The builder-of-the-model rule shall not apply to any CL Speed event for any age grouping.

### 3. Entry Participation Requirements

#### 3.1.

Junior and Senior entrants must fly their own models unless they meet the requirements for a proxy flier. Others may operate the starting equipment.

#### 3.2.

An Open entrant may either fly his entry or start and regulate the engine and launch the model. Others may operate the starting equipment. If the entrant elects not to fly the model, the designated pilot must show a valid AMA license and be in the same age group as the entrant; (or if the pilot is younger the pilot must have the event director's approval.) The Contest Director must assure himself that the younger pilot is capable of safely flying the aircraft. If the entrant elects not to fly the model, he shall clearly

indicate to the officials that he is going to perform the starting function and give the name of his designated pilot for the attempt. The entrant may not change his elected function after the starting time for the attempt has begun. There are no restrictions on using different pilots on different attempts or on the entrant from changing his function on different attempts. The provision above takes precedence over the Proxy Flying and Team Entry

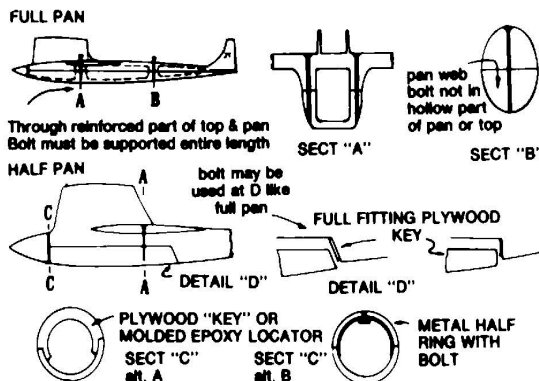

paragraphs of the Sanctioned Competition section of these regulations.

These provisions do not apply to contestants who are flying for Individual, Category, Team, or Club Championship points; such contestants still are required to fly their own entries except in the case where they are eligible for a proxy flier.

#### **4. Classification of Control Line Speed Models**

Models powered by reciprocating engine(s) are classified by total piston displacement of engine(s) as follows. There is only one (1) classification for models powered by jet engine(s).

Class ½A: .0000—.0504 cubic inch

Class A: .0505—.1525 cubic inch

Class B: .1526—.3051 cubic inch

Class D Open: .3052—.6500 cubic inch

½A Profile Proto: .0000—.0504 cubic inch

Sport Speed 21: .198—.2135 cubic inch

.21 Proto: .00—.2135 cubic inch

Formula 40: Senior/Open: .2800—.4028 cubic inch

Jet: Seniors are permitted to fly in the Open D class.

Separate records will not be maintained, but Seniors may apply for Open D records. Juniors are not permitted to fly Formula 40 or D speed.

##### **4.1.**

If desired, two (2) or more classes may be combined, so long as the displacement limits given are observed. When classes are combined, such combination shall be specified in the sanction applications and shown in contest announcements. Example: if three (3) events are scheduled and classes ½A and A are to be combined, the events should be listed Class ½AA, Class B and Class D; if classes B and D are to be combined, events should be listed Class ½A, Class A and Class BD; and so on.

Regulations for ½A, A, B, D, and Jet follow immediately. Special conditions for Proto models follow in paragraph 19. See separate sections for .21 Sport Speed and Formula 40.

## ***5. Model Design and Construction***

There is no wing loading, power loading or cross-sectional requirements. The method of “hold-down” construction for holding two parts of the model together shall be considered, in the Contest Director’s opinion, to be at least as strong as the methods illustrated.

### **5.1: Number of Models**

Each contestant shall be allowed two (2) models per event. A competitor may interchange various parts as he wishes provided the resulting complete model conforms to the rules of the contest. Each contestant is allowed to use the two (2) models in any combination, utilizing at most four (4) attempts, to make at most three (3) official flights. Only the two (2) models per event processed at the time of entry will be permitted. Each model must have the same AMA number(s) and must be identifiable by distinguishing marks or characteristics so they can be differentiated for pull test requirements.

### **5.2: Model Weight**

Models shall be weighed in complete, ready-to-fly condition, including fuel. Maximum model weights and pull tests shall be based on these weights.

CL Speed								
			Required Min Diameter of Each Line					
			Single Strand			Multi-Strand		
Class Engine Size (cubic inch)	Max Model Weight with Fuel	Min Line Length	1 Line	2 Lines	3 Lines	2 Lines	3 Lines	Pull Test
1/2A .0000 - .0504	10 oz.	47'5 5/8"	.014"	.012"	--	--	--	48G
1/2 A Proto .0000 - .0504	9 oz.	42'	--	.010"	--	--	--	32G
A 0606 - .1525	22 oz.	65'	.022"	.018	--	--	--	56G
B .1526 - .3051	35 oz.	70'	.026"	.020"	--	--	--	48G
D Open .3052 - .6500	47 oz.	70'	.033"	.026"	--	--	--	52G
Jet	47 oz.	70'	.033"	.026"	--	--	--	56G
.21 Proto Speed .198-.2135	30 oz	60'		.018"	--	--	--	36G
.21 Sport Speed .198 - .2135	30 oz.	60'		.018"	--	--	--	40G
Formula .40 Speed .2800 - .4028	34 oz.	60'		.020"	--	--	--	48G

## 6. Engine Restrictions

Open 1/2A, Open A, and Open B are the only Speed events without exhaust extension restrictions.

### 6.1.

Sixty percent of the actual piston displacement of four-stroke cycle engines shall be taken for competition classification purposes.

### 6.2.

No restrictions are placed on the design of the engine(s) used for Jet Speed, except that the total internal cross-sectional area of the tailpipe(s) at the point of minimum cross-section shall not be greater than 1.25 square inches. Afterburners are not permitted, but augments tubes and/or other ducting devices not making use of combustion may be used.

### **6.3.**

Control Line Speed models are exempt from any muffler requirement and noise standards or limits contained in the General or Control Line General Section of this book or in any other document.

### **6.4.**

½A Profile Proto is restricted to “open-face” exhausts for all age classes. The 21 Sport Speed, Senior/Open Formula 40, Open D, Junior/Senior ½A, Junior/Senior A, and Junior/Senior B Speed events are restricted to constant- diameter exhaust extensions (“mini-pipes”) or open-face exhausts. The overall length of the constant-diameter exhaust extensions is restricted to at most six (6) inches measured from the center line of the cylinder along the center line of the exhaust system to the end of the exhaust extension. No tuned or non-tuned megaphone or expansion chamber exhaust extensions shall be allowed in these events.

### **6.5.**

Juniors and Seniors may elect to use the Open class exhaust restrictions when flying at contests with their class combined with the Open class or if they elect to fly in the Open age group at a contest that does have a separate Open category. National Junior or Senior records may be set only when the Junior or Senior class exhaust restrictions are followed. Juniors and Seniors may apply for Open records when Open class exhaust restrictions are followed.

# SUGGESTED PYLON FABRICATION METHODS

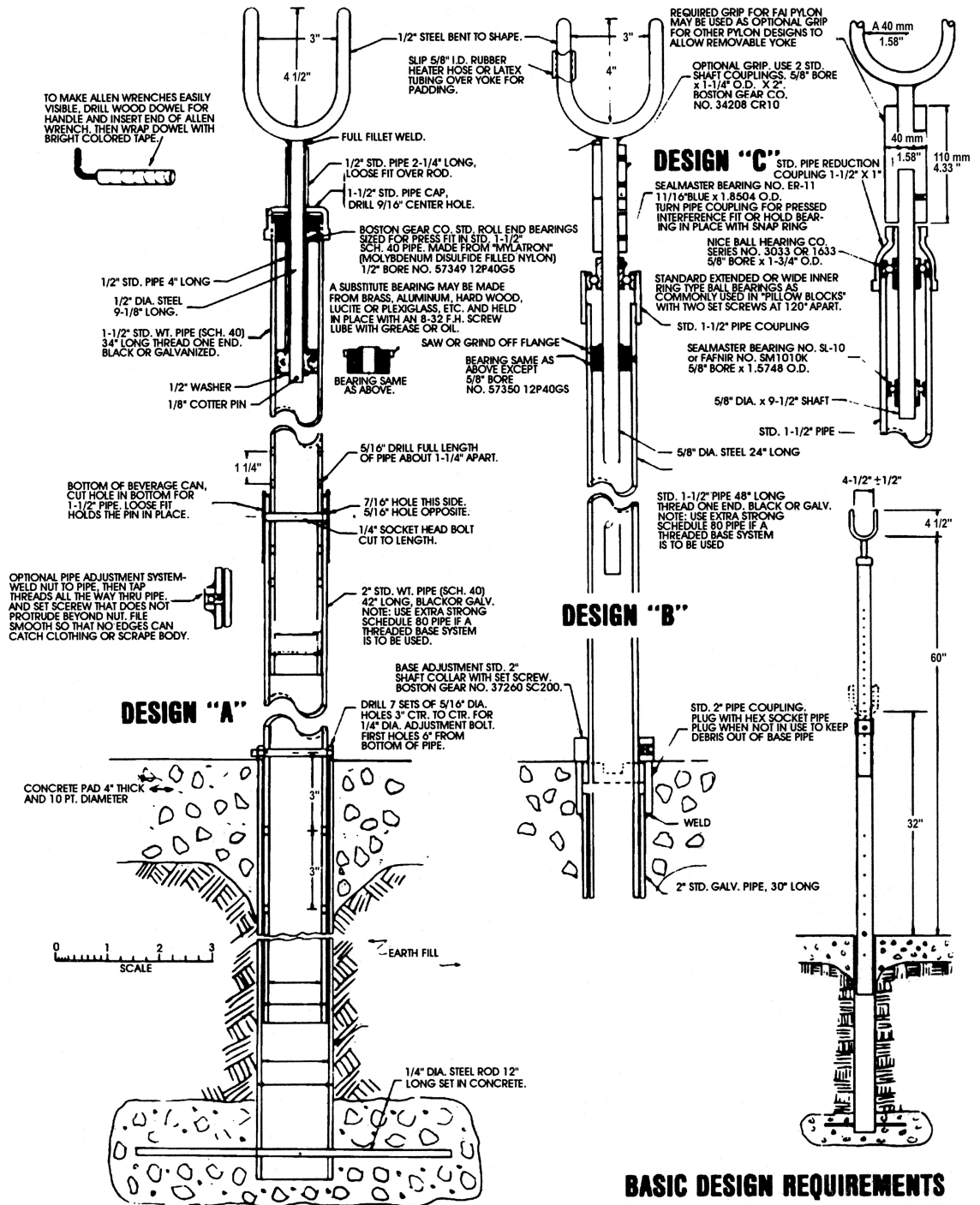

## BASIC DESIGN REQUIREMENTS

Pylon fabrication methods are optional. However, it is recommended that the design be capable of the minimum and maximum yoke heights shown and that the fork be within the limitations given. The pylon shall be capable of withstanding a 150-pound horizontal pull on the yoke when it is at the maximum height position.

## **6.6: Engine Use Restrictions**

Once an engine (i.e., crankcase, piston and sleeve or jet head and tailpipe) has been used by a contestant to make an official attempt in an event, the same engine cannot then be used by another competitor in that same event in the contest. This does not restrict the number of different engines a contestant may use to make his attempts in an event, nor does it mean that engine commitment to a given competitor must be made at the time of processing as is the practice in FAI. Engine commitment is not made to a given contestant until said engine is used to make an official attempt for that contestant. This rule is solely intended to prevent the same engine from being used by more than one (1) competitor in a given event at a given contest.

## **7. Fuel**

Fuel of standard formula will be supplied by the contest organizers. The percentages of ingredients in the fuel mixture supplied must be accurate, consistent with careful and accurate mixing techniques. Fuel for two-cycle glow plug engines shall contain 10% nitromethane, 20% lubricant, and the rest shall be methanol. Fuel for jet engines shall consist of 80% methanol and 20% Nitromethane.

## **8. Control Line Specifications and Pull Test**

As per chart. Lines of braided or stranded construction will not be allowed in any CL Speed event. All lines used to control flights shall be of steel music wire, type ASTM A228, only. The line sizes stated in the chart are applicable regardless of model's weight.

### **8.1.**

When a crossbar is used on a Speed handle to engage the pylon fork, the line length is measured from the front of the bar to the airplane centerline. The safety thong must still be used, and the pull test is per the chart.

### **8.2.**

In the event of a line failure on a two-line model, the remaining line must be scrapped due to potential stress damage.

### **8.3.**

A pilot acting as a designated pilot for other contestants shall at the start of the contest perform a pull test equal to the pull of the heaviest model he will fly during the contest. The owner of a model or a person he designates will pull test the model before each flight.

## **9. Control Handle**

Handles providing for easy adjustment of overall length of control lines are prohibited in all Speed and Proto Speed events.

## **10. Competition Flying**

### **10.1: From a Pylon**

The contest director shall provide a substantial fixed pivot post or pylon from which all official Speed flights shall be controlled. The pylon shall be between elbow and shoulder height, preferably adjustable, and equipped with a freely revolving yoke hand rest for centering the flight path. During the entire period when official timing is being made, and for at least two (2) laps immediately preceding, the contestant shall keep his wrist (defined as within three (3) inches of the wrist bone, or his hand holding the control handle or control handle device, on the hand rest between the forks. “Wrist” or “hand” does not apply if a crossbar on the handle is used to engage the pylon fork on the side opposite the airplane. (See paragraph titled “Control Line Specifications and Pull Test” for measuring line(s) if crossbar is used.)

### **10.2: Without a Pylon**

When a pivot post or pylon is not provided, or when weather conditions do not permit their use, a six (6) foot diameter ring is to be marked at the center of the flight circle within which the flier shall remain while the flight is being timed. Such flights will not be considered for record purposes.

### **10.3: Whipping**

Whether flying from a pylon or without, any attempt by the flier to shorten the effective length of the control line(s) or touch the line(s) between the controls handle (device) and the model shall constitute a foul. Except as specified in 10.4, it shall be mandatory at every sanctioned meet for one (1) official, with field glasses, to be assigned the duty of watching the flier to determine if he is leading (whipping) the model. Any attempt to whip the model more than is necessary to get it safely airborne shall constitute a foul, disqualifying the flight. Two (2) such fouls in an event shall disqualify all flights in that event. This shall apply to all classes in the Speed event.

#### **10.3.1.**

At any time during the clocking, any excessive vertical movement of the monoline handle stem shall constitute an attempt to shorten the effective length of the line (see 10.3.). Excessive movement of the tip of the stem from a straight line formed by the stem and the flying line at any time during the flight shall not be allowed. This

is a judgment call by the official with the field glasses. The monoline system was designed to control the model by twisting the line, not by raising and lowering the control device. Although it would take a considerable bend to actually shorten the line enough to affect the timed distance, excessive movement at the tip of the stem causes a bend of the flying line at that point, and repeated bending at this point can greatly weaken the line.

#### **10.4.**

In any Class A or B contest or any meet where speed is not required to be flown from the pylon, no field glasses are required.

### **11. Timing of Flights**

The time shall be taken by either timing officials equipped with 1/100-second resolution digital stopwatches (referred to as the manual timing) or by an optical electronic system with equal or better resolution or accuracy or by combination of the manual and electronic methods.

#### **11.1.**

In the case of manual timing, three (3) officials shall time flights in unison from a point on the opposite side of the circle from the timing pole or marker. In a Class A or B contest or any meet where speed is not required to be flown from the pylon, only two (2) stopwatches shall be required.

#### **11.2.**

In the case of electronic timekeeping, two electronic systems shall be used. One system shall be designated the primary system and the speeds from this system shall be used for classification purposes. The other system shall be designated the secondary system and shall be the required back-up system. Only in cases where there is a failure of the primary system may the speeds from the secondary back-up system be used for classification purposes.

#### **11.3.**

A single electronic system may be used if backed up by two (2) manual timekeepers. In this case, the manual timekeepers shall be positioned on the opposite side of the circle from the electronic system sensor.

#### **11.4.**

Timing shall start immediately after the second complete lap has been flown from the pylon according to Competition Flying From a Pylon. If the flier so chooses, he or she or the pit crew may give a prearranged signal to the timers as to when to start the two (2) preliminary laps before

timing starts; if this is done, timing shall start after at least two (2) full laps in the pylon have been completed following the prearranged signal to the timers (in accordance with Competition Flying From a Pylon). The reference for counting laps and starting watches is when the model passes the timing pole or marker.

## ***12. Scoring of flights.***

The best official flight by each competitor in an event, in terms of miles per hour, shall be used for competition and record scoring.

### **12.1.**

To separate the competitors in the case of a tie, the average of the competitor's two (2) best flights will be taken. In the case of the two (2) best flights still producing a tie, the average of the three (3) best flights will be taken to determine the winner.

### **12.2.**

To compute the speed in miles per hour for ½ A Speed, use the formula:  
 $MPH = 1016.79/\text{time in seconds}$ .

### **12.3.**

To compute the speed in miles per hour for A Speed, use the formula:  
 $MPH = 1670.76/\text{time in seconds}$ .

### **12.4.**

To compute the speed in miles per hour for ½ A Proto Speed, 21 Sport Speed, B Speed, D Speed and Jet Speed use the formula:  $MPH = 1799.28/\text{time in seconds}$ .

### **12.5.**

To compute the speed in miles per hour for 21 Proto Speed and Formula 40 Speed use the formula:  $MPH = 3598.56/\text{time in seconds}$ .

### **12.6.**

When manual timing is used, the time for calculation of speed shall be determined as follows: The times from three watches shall be totaled. The total of the watches will be divided by three. All results will be truncated to three decimal places.

### **12.7.**

If using manual timing, records shall be recognized only when no more than .12 second variation exists between any of the three (3) watches. If the watches do not read within this required tolerance, and a record has been broken, the flier may request another attempt permitted. In the case when no record is broken, or if the flier does not elect to take another attempt, the average of the two (2) watches that are within .12 second of each other shall be taken for scoring purposes, disregarding the results of the third watch. If no two (2) of three (3) watches are within .12 second of each other the flier has the right to ask for another attempt, with the previous flight being cancelled, or to request that the average of the three (3) watches be used for scoring.

### **13. Official Flight.**

An official flight occurs when the model has successfully completed the timed distance in accordance with these regulations, and an official timing (clocking) has been recorded.

### **14. Number of Flights**

Each contestant shall be allowed four (4) attempts for three (3) official flights.

### **15. Engine Starting Time**

The maximum time allowed for starting engines shall be three (3) minutes from the time the initial propeller turning sequence begins (or air is applied to the intake of a jet engine) until the engine is running under its own power. The model may land and take off as many times as the flier wishes within the allowed starting time as long as the attempt is not automatically terminated for any of the reasons stated under the “definition of an attempt.”

### **16. Definition of an Attempt**

An attempt is the process of trying for an official flight within the allowed starting time. An attempt also refers to the failure to achieve an official flight during the starting time allowed. An attempt is declared when a foul is called as described in other paragraphs. An attempt is declared when the starting time has elapsed.

### **16.1.**

An attempt is automatically terminated and no further starting time is allowed when any of the following takes place: a part of the model is lost during the flight (this does not include propellers, but does include wheels and/or tires); a removable takeoff gear does not fall free of the model as it becomes airborne but does fall free later during the flight and it is not retained by the required safety line; the engine loses all or part of the propeller, and the engine continues to run and at excessive rpm (“shaft run” or “scream out”) but the model does not become or remain airborne.

### **16.2.**

If the engine throws part of the propeller, but does not run at excessive rpm (does not “shaft run” or “scream out”) after becoming airborne but without completing an official clocking, the Contest Director shall inspect the model before allowing the attempt to continue. At any time after a model has become airborne it then comes in contact with the ground or other obstacle while under power, resulting in an engine cutoff (not a shaft run), the contest director shall inspect the model before allowing the attempt to continue. This shall also be done when a jet model makes contact with the ground, causing the engine to shut off. This inspection time shall not constitute a part of the “starting time.”

### **16.3.**

In the case of a large number of contestants and short flying hours, the contest director may elect to add further restrictions to the flying procedures in order for more flights to be flown in a given time. Example: allow only two (2) minutes from the time the flier is called to fly until his starting time begins, or a similar rule to speed up the contest. If any such procedures are to be used, they must be announced prior to the start of competition and preferably in contest advertisements.

### **17. Distance of Timed Course**

For competition and record purposes, the model must complete the following distances.

Class Distance	No. Laps
½A	5
½ Profile Proto ½ mile	10
A	6
B ½ mile	6
D Open ½ mile	6
Jet ½ mile	6

### **18. Timing Pole—Height Marker**

A pole or reference marker shall be provided outside of the flight circle for timing and judging flight. Maintaining flight in excess of 15 feet, in any class, for more than ½ lap during the entire period when official timing is being made, including the three (3) laps immediately preceding, shall constitute a foul.

## **19. 1/2A Proto Speed, event 305**

All speed regulations for the size class of model shall be applicable except for the additions and modifications following.

### **19.1.**

Design of 1/2A Proto Speed Model. Proto Speed models need not be scale; however, the design must resemble that of a full scale airplane. Models must have a profile fuselage, rudder or butterfly tail, and a clear cockpit or cabin in proportion to the total model. No pod-and-boom fuselages, flush or prone cockpits, or flying-wing designs will be permitted unless they are scale models of full-scale aircraft. The complete model with the exception of the engine, tank, bellcrank and landing gear must be finished with an opaque paint. The model may also be colorfully trimmed. Clear or tinted finishes that show the color of the construction material are not allowed. Models must satisfy the Control Line General profile definition.

### **19.2: 1/2A Profile Proto Specifications**

- a. Minimum wing span, 14" (12" for biplane).
- b. Minimum wing area, 45 square inches.
- c. Minimum fuselage length shall be 12 inches from the face of the prop drive surface to the end of the fuselage when viewed 90 degrees to the side of the profile fuselage.
- d. Must have clear canopy.
- e. Must have fixed landing gear, with minimum of two (2) main wheels permanently attached.
- f. Main wheels must have a minimum diameter of 7/8 inches.
- g. The landing gear must include at least two (2) main wheels of equal diameter, which are laterally separated from each other by a distance of at least two (2) wheel diameters.
- h. Engines equipped with exhaust extensions of any kind are not permitted.
- i. The control system, consisting of leadouts (if used), bellcrank, pushrod and control horn will be totally exposed and external to normal airplane contours. The leadout wires (or flight wires if no leadouts are used) will not be recessed into the wing, the pushrod will not be mounted inside the fuselage, nor will the bellcrank be allowed to be mounted or hidden inside the wing or fuselage. The leadout tip guides may be inset into the wing but

should not be more than 1/4 inch in length. The entire control system as defined above must be visible when the model is viewed in plain view from top and/or bottom with the controls in neutral.

j. Models must have the engine piston and cylinder parallel with the wing and the top of the cylinder facing the outside of the circle and a fully exposed tank mounted on the same side of the fuselage as the engine. The tank may not form a fairing behind the cylinder head, but a fairing behind the tank is permitted.

### **19.3: Launching (Proto)**

Models shall take off from the ground or runway under their own power.

### **19.4**

Timing of Flights (Proto) shall be the same as for the respective size class of Control Line Speed, except as follows.

#### **19.4.1.**

The timers shall be located on the opposite side of the circle from the launch point (180 degrees from launch point). The timing mark is an imaginary straight line going from the timers and passing through the pylon to the point where the model is launched. Sighting reference for counting laps and terminating the clocking is as the model passes behind the pylon. The flier may select his launching location.

#### **19.4.2.**

Proto Speed will be timed from the instant the model is released for takeoff. The contestant will be allowed a maximum of 1½ laps in which to get the model airborne before he is required to fly from the pylon as specified under “Competition Flying From a Pylon.” However, any attempt to whip the model more than what is necessary to get it airborne during the first lap and one half shall constitute a foul, disqualifying the flight. Any such whipping to get the model safely airborne must cease immediately when the model becomes airborne and is in a normal attitude.

### **19.5: Scoring of Proto Flights**

The best official flight by each competitor in an event, in terms of miles per hour (mph), shall be used for competition and record scoring. When manual timing is used, the average of the three (3) watches shall be used for scoring. Records shall be recognized only when no more than .24 second variation exists between any of the three (3) watches. If the watches do not read within this required tolerance, and a record has been broken, the flier may request another attempt, and the flight with the

discrepancy shall be cancelled and another attempt permitted. In the case when no record is broken, or if the flier does not elect to take another attempt, the average of the two (2) watches that are within .24 second of each other shall be taken for scoring purposes, disregarding the results of the third watch. If no two (2) of the three (3) watches are within .24 second of each other, the flier has the right to ask for another attempt, with the previous flight being canceled, or to request that the average of the three (3) watches be used for scoring.

### **19.6.**

To separate the competitors in the case of a tie, the average of the competitor's two (2) best flights will be taken. In the case of the two (2) best flights still producing a tie, the average of the three (3) best flights will be taken to determine the winner.

## **20. Records**

Fliers establishing or surpassing a national speed record shall be required to make a supporting or verification flight within five (5) **percent** of the record flight on the same day as the record setting flight before it can be recognized for record purposes. Basis for this supporting flight shall be as follows.

### **20.1.**

After a record is broken during the contest, the flier shall be granted three (3) attempts to make a supporting flight within five (5) **percent** of the record flight. The flier has the option of making the supporting flight immediately after the record flight or at any time during the same day; however, the flier should not be permitted to delay the contest while he makes preparations for the supporting flight, but he should be worked into the starting line as soon as is reasonable. All supporting flight attempts shall be subject to the same starting restrictions as official contest flights (see Engine Starting Time paragraph).

### **20.2.**

Any official flights attempted during the contest after a record is broken shall be deemed attempts to satisfy the requirement of a supporting flight. The first three (3) official flights flown or the first four (4) attempts shall be considered the contest flights. This shall also hold true for multi-day contests when the same event can be flown on more than one (1) day.

### **20.3.**

The most extreme case would occur where a flier broke the record on his third official flight (fourth attempt) during the contest. He would then be allowed a maximum of three (3) attempts after the contest to come within five (5) **percent** of the record flight.

#### **20.4.**

If the flier's first or second attempt for a supporting flight is within the five (5) mph required, no further attempts shall be given for the supporting flight.

#### **20.5.**

If the flier has made another official flight during the contest which was within the required five (5) mph, he will be required to use this as the supporting flight for record purposes.

#### **20.6.**

If the supporting flight is faster than the record flight, it will become the record flight and the other the supporting flight. Under no circumstances can the record resulting from a supporting flight be over five (5) mph faster than an official contest flight. If the supporting flight was flown after contest hours and exceeded the contest record flight, the "after hours" flight can be used only for record purposes; it cannot be used as an official contest flight for scoring purposes.

#### **20.7.**

AMA records for FAI 0.15 cubic inch speed shall be considered only when the flights have been made according to the FAI Sporting Code or those special rules in effect for FAI Selection Finals; they must also meet the requirements of the supporting flights as described in this section.

## **21 PROTO SPEED FOR EVENT 306**

---

### ***1. Objective***

It is the purpose of 'New Proto' to fly semiscale, realistic airplanes in CL Speed competition. Proto speed models need not be scale models however true scale subjects are highly encouraged.

### ***2. Design***

The model must have a full fuselage and rudder. Butterfly-type stabilizers are not acceptable unless it is a true scale model. The engine can be mounted in any position, if mounted sideways model must have matching opposing cowl. A model with a small fuselage and helmet cowl used on traditional speed model designs is not acceptable. The model must have a cockpit or cabin as laid out in specifications following. No pod-and-boom fuselages, flush or prone cockpits or flying wing designs will be accepted unless they are actual scale models of full-size craft. The engine must be fully cowled except in the case of a scale model. If the builder wishes, the glow plug or head fins may be exposed. Wing area

enclosed in the fuselage will be considered, but area of fillets shall not be counted. **The model shall be colorfully painted or trimmed, so as to permit clear finished models.** The entrant's AMA number must be permanently affixed to the upper right-hand wing surface at least 1 inch high.

### ***3. Airplane Specifications***

The model shall have a minimum of 125 square inches of wing area; the stabilizer must be a minimum of 25% of the wing. Rudder/fin area shall be a minimum of 5% of the wing area. The minimum wingspan shall be 24 inches or 16 inches for a biplane. The minimum distance from the trailing edge of the wing to the leading edge of the stabilizer must be 5 inches. The model must have a clear canopy, a minimum dimension of 3½ inches in length by 1 inch high and 1 inch wide and shall house a scale pilot with a minimum of 1 inch in height. Pilot must have clear unobstructed view. The landing gear must be of the fixed type and similar to a full-size airplane. The main landing gear shall consist of two wheels spaced at least 6 inches apart between wheel centers. Wheels must have a minimum diameter of 1½ inches. **The wing and stabilizer must be of equal span with no asymmetry, maximum deviation is 1/4 inch.**

True scale subjects are exempt from all specifications other than minimum 125 square inches of wing area.

### ***4. Engine, Propeller and Fuel System***

The engine shall have a maximum size in displacement of .2135 cubic inches. An open exhaust or minipipe type exhaust system only. A minipipe cannot be longer than six inches from the centerline of the engine bore to the end of pipe. The inside diameter of the pipe shall be of constant size. Any fuel system is acceptable and the use of a shutoff is encouraged. Only standard two bladed propellers are acceptable either wood or composite.

### ***5. Flying Lines***

**Only two wire type control systems are acceptable. Minimum two wire sizes shall be (2) .018" x 60'-0". The model and control system shall be subjected to a 36g pull test.**

### ***6. Fuel***

Fuel shall be of standard composition containing 10% nitromethane, 20% lubricants, and 70% methanol. The fuel will be supplied by contest management.

### ***7. Distance of Timed Course***

The model will be times from the instant the model is released from takeoff for 14 laps (1 mile). The flier will be allowed 1½ full laps to get model airborne before entering the pylon. Any attempt to whip the model more than is necessary to get airborne during the first lap shall constitute a foul and the flight will be disqualified.

## **.21 SPORT SPEED FOR EVENT 307**

---

### **1. Applicability**

All pertinent AMA regulations (see sections titled Sanctioned Competition and General), the General Control Line rules and the CL Speed rules shall apply, except as specified below.

### **2. Engine Restrictions**

Any engine from .198 to .2135 cubic inch displacement may be used. Open exhaust of a minipipe may be used. The minipipe cannot be longer than six (6) inches from center line of engine bore to end of pipe. The inside diameter of the pipe shall be of constant size.

### **3. Model Design and Construction**

#### **3.1.**

Models are to be of standard configuration. No asymmetrical designs allowed.

#### **3.2.**

There may be no more than one (1) inch differential between the lengths of the left and right wing. This dimension shall be measured from the wing tip to the center line of the fuselage.

#### **3.3.**

The minimum distance between the leadouts at the wing tip shall be no less than .200 inches.

#### **3.4.**

The model can be designed with or without the use of a metal speed pan. Profile fuselage models are permitted.

### **4. Propellers**

Only standard two-blade propellers are permitted. No single-blade propellers will be allowed.

### **5. Size, Construction, and Length of Control Lines**

Size and length as per chart. Lines shall be constructed as described in the General Control Line section. Lines of braided or multistrand construction will not be allowed. No single line control systems are allowed. A 40G pull test is required.

### **6. Flight Timing**

The model shall be timed for seven (7) laps (1/2 mile) after two (2) complete laps are flown in the pylon.

### **7.**

Flight elevation shall be as per paragraph 8 page 11 “Formula 40.”

### **8.**

Flight scoring shall be as per section 12.5 “21 Proto speed and Formula 40.”

### **9. Records**

Requirements are the same as those listed in the Records paragraph of the CL Speed section.

---

## **FORMULA .40 SPEED FOR EVENT 308**

---

### **1. Applicability**

All pertinent AMA regulations (see sections titled Sanctioned Competition and General), the General Control Line rules and the CL Speed rules shall apply, except as specified below.

### **2. Formula 40 Description**

This event is intended to be a common ground for competition between monoline speed fliers and two-line racing fliers (and other two-line pilots) using an engine size that is rapidly becoming the most highly developed and most commonly used of all model airplane racing engines. Because of the requirement for two (2) lines and fixed landing gear, it is hoped that newcomers will also enter this event. Formula 40 is limited to Senior and Open class fliers. Juniors are not permitted to fly Formula 40.

### **3. Engine Restrictions**

Engine displacement is as per the chart. No tuned or untuned megaphone or expansion chamber exhaust extensions shall be allowed. Constant diameter type exhaust extensions are allowed, but only if the overall length as measured from the center line of the cylinder along the center line of the exhaust system does not exceed six (6) inches. There are no additional engine restrictions other than those which appear in the CL Speed section.

Open-face exhausts are, of course, permissible.

### **4. Formula 40 Model Design and Construction**

There are no wing loading, power loading or cross sectional requirements. The method of “hold down” construction for holding two (2) parts of the model together shall be considered, in the Contest Director’s opinion, to be at least as strong as the methods illustrated in the CL Speed section. Models shall have a fixed landing gear with a minimum of one (1) wheel.

### **5. Launching**

Models shall take off from the ground or runway under their own power, unassisted (no hand launching or dollies).

### **6. Size, Construction, and Length of Control Lines**

Size and length as per chart. Lines shall be constructed as described in the General Control Line section. Lines of braided or multistrand construction will not be allowed. No single-line control systems are allowed. A 48G pull test is required.

### **7. Formula 40**

Flight timing shall be from a standing start for 14 laps. The flight timing procedure shall be the same as for ½A Profile Proto.

### **8. Flight elevation**

Shall be a maximum of 15 feet. Maintaining flight in excess of 15 feet for more than ½ lap during the entire officially timed flight will constitute a foul.

### **9. Scoring of flights**

Shall be the same as for ½A Profile Proto.

### **10. Records**

Requirements are the same as those listed in the Records paragraph of the CL Speed section.

---

## **ESTABLISHMENT OF LINE SIZES AND PULL TESTS IN CL SPEED**

---

### **General**

The AMA has adopted the following guidelines for determining minimum line sizes and pull tests in CL Speed. In all cases, wire strength shall be based upon minimum breaking strengths for ASTM A228 music wire as indicated in the chart. Maximum expected flight loads are based on record speeds in each class, and maximum weights where applicable. For Speed events permitting both single and two-line control systems, the established records shall be used for both monoline and two-line application unless separate records are established.

Maximum Expected Flight Loads. Maximum expected flight load, in Gs, is calculated as shown:

$$\text{Max load (Gs)} = \frac{.0668 \times 1.2 \times V^2}{R}$$

where V = record speed in mph, and R = line length in feet. Maximum expected flight load in pounds is equal to maximum load in Gs, times maximum model weight in pounds.

When calculating the expected flight loads for the "acceleration" events, 1/2A Proto, .21 Proto and F-40 speed, ect, use 107% of the Record Speed as a base. Multiply the Record Speed by 1.07 and use this number as "V" for calculating the Max Expected Flight Loads."

$$\text{Max load (pounds)} = \frac{.0668 \times M \times 1.2 \times V^2}{R}$$

M = maximum model weight (pounds), R = line length in feet.

### ***Line Sizes***

The line sizes for single line applications shall be such that the maximum expected flight load in pounds shall not exceed 56% of the minimum breaking strength of the wire size being utilized. If the maximum expected flight load exceeds this number, the line size shall be increased to the next standard wire size that will satisfy the above criteria. Additionally, for two-line control systems, the maximum expected flight load in pounds must not exceed 86% of the minimum breaking strength of one wire. In the event this number is exceeded, the line size shall be increased as described above.

### ***Pull Tests***

The pull tests for CL Speed shall be such that the pull test, in Gs, will be at least 1.10 times the maximum expected flight load in Gs. In the event the pull test is less than the prescribed value, the pull test shall be increased to a value where the pull test in Gs is at least 1.15 times the maximum expected flight load in Gs.

### ***Implementation***

It is the responsibility of the Control Line Speed Contest Board Chairman to monitor and maintain the line sizes and pull tests as described above. In the event a new record is established which necessitates an increase in line size, pull test, or both, any changes will be published concurrently with announcement of the new record. Changes will become effective immediately upon publication in Model Aviation magazine. Changes are to be automatic, with no action required by the Control Line Contest Board or the AMA Executive Council.

---

## **ELECTRIC EVENTS**

---

### ***Definition***

Electric powered model airplanes are model airplanes which are propelled only by electric motors which receive their power from onboard battery packs. No electrical connection to the ground is permitted during flight. In events other than record performances that specifically preclude on board battery chargers, except as specifically allowed by the contest director for competition purposes, no on board battery charges (such as, for example, solar cells) shall be allowed.

General Characteristics:

Maximum surface area: 2335 sq. in. (150 dm. sq.)

Maximum weight: 11 pounds (5 kilograms)

Maximum surface loading: 24.59 oz. per sq.ft. (75 gr/dm sq.)

Maximum battery voltage: 42 volts

Individual battery cells can be of any commercially available chemistry type, and must be a rechargeable type.

### ***General Specifications***

The use of gear boxes and multiple motors is permitted. Folding props are not permitted. No electrical power may be transmitted through the control lines. The use of radio control is not permitted. All applicable sections of Control Line General and Control Line Speed shall govern model and line construction and the timing of flights. There shall be no loading requirements for Electric Speed models.

### ***Class A Control Line Speed For event 334***

Any motor(s) allowed but the battery pack is limited to a maximum of 8.4 volts nominal of any battery type.

The model must successfully pass a 36G pull test prior to flight.

The flight speed will be calculated based on the six (6) laps of the circuit following two complete laps in the pylon. To compute the speed in miles per hour for A Speed, use the formula: MPH = 1670.76/average time in seconds.

Two (2) control lines, ASTM A228 solid steel, shall be used and they shall be a minimum of 65 feet long. Multi strand lines are not permitted. The minimum diameter of each line shall be .016 inches. Maximum model weight shall be 30 oz.

The CD will determine whether hand launches are permitted.

### ***Class B Control Line Speed For event 335***

Any motor(s) allowed with the battery pack limited to a maximum of 42 volts nominal of any battery type.

The model must successfully pass a 28G pull test prior to flight.

Two control lines, ASTM A228 solid steel must be at least .020 inches in diameter and not shorter than 70 feet in length. Multi strand lines are not permitted. Maximum weight shall be 60 oz.

Flight speed will be calculated based on six (6) laps of the circuit following three (3) complete laps in the pylon.

The CD will determine whether hand launches are permitted.