



AMA[®] RULEBOOK

2026-2027

Radio Control
Fixed-Wing
Scale



RULES GOVERNING MODEL AVIATION COMPETITION IN THE UNITED STATES

Amendment Listing

| Amendment Topic | Publication Date | Description |
|--|------------------|---------------------------|
| Manuever update | 1/01/2022 | All Manuever lists |
| Added Scoresheets | 1/01/2022 | Scoresheet section |
| Two new classes of Pro-Am Expert | 1/01/2022 | Section 16 |
| RC equipment restrictions | 1/01/2022 | Section 10 |
| Clarify wording in RC Pro-Am Expert Class divisions | 8/28/2023 | Event 520, Sections 1 & 2 |
| Name change for RC Pro-Am Classes | 1/1/2024 | Event 520 |
| Deletion of manuevers “Straight Flight Out” and “Straight Flight Back” | 1/1/2024 | Manuever section |
| Class Matrix established | 1/1/2024 | Section 2. General |
| Builder of the Model Rule | 1/1/2024 | Section 4 |

Table of Contents

| | |
|--|----------|
| RC Fixed Wing Scale General | 1 |
| 1. <i>Applicability</i> | 1 |
| 2. <i>General</i> | 1 |
| 3. <i>Safety Declaration</i> | 1 |
| 4. <i>Scale Builder–Flier Rule</i> | 2 |
| 5. <i>Special Events</i> | 3 |
| 6. <i>Profile Fuselages</i> | 3 |
| 7. <i>Minimum Flight Score</i> | 3 |
| 8. <i>Pyrotechnics</i> | 3 |
| 9. <i>Static Scoring</i> | 3 |
| 10. <i>RC Equipment limitations</i> | 3 |
| 11. RADIO CONTROL SPORT SCALE | 4 |
| 1. <i>General</i> | 4 |
| 2. <i>Safety Requirements</i> | 4 |
| 3. <i>Outdoor Events:</i> | 5 |
| 4. <i>Indoor Events:</i> | 6 |
| 5. <i>Model Requirements</i> | 6 |
| 6. <i>Proof of Scale</i> | 7 |
| 7. <i>Static Judging:</i> | 9 |
| 8. <i>Static Scoring</i> | 11 |
| 9. <i>Flight</i> | 11 |
| 10. <i>RC Flight Plan</i> | 13 |
| 11. <i>RC Flight Scoring</i> | 14 |
| 12. <i>RC Sport Scale Classes</i> | 14 |

| | |
|---|-----------|
| 13. Official Score | 15 |
| RADIO CONTROL DESIGNER SCALE | 16 |
| 1. Eligibility | 16 |
| 2. Craftsmanship | 16 |
| RADIO CONTROL Pro-Am | 16 |
| 1. Pro-Am Pro Division 1: | 16 |
| 2. Pro-Am Pro Division 2: | 16 |
| 3. Eligibility | 16 |
| 4. Static Judging | 16 |
| 5. Flying | 17 |
| 6. Scoring | 17 |
| RADIO CONTROL TEAM SCALE | 17 |
| 1. Eligibility | 17 |
| 2. | 17 |
| 3. | 17 |
| RADIO CONTROL OPEN SCALE | 17 |
| 1. Eligibility | 17 |
| 2. Classes | 17 |
| RADIO CONTROL SCALE FLIGHT JUDGING GUIDE | 18 |
| 1. Purpose | 18 |
| 2. Principles | 18 |
| 3. Precision | 18 |
| 4. Presentation | 19 |
| 5. Realism | 20 |
| 6. Accurate and Consistent Judging | 21 |
| 7. Judging Individual Scale Operations and Flight Maneuvers | 22 |

| | |
|--|-----------|
| RADIO CONTROL SPORT SCALE SOARING | 74 |
| 8. <i>Applicability</i> | 74 |
| 9. <i>Definition</i> | 74 |
| 10. <i>Builder–Flier</i> | 74 |
| 11. <i>Proof of Scale</i> | 74 |
| 12. <i>Static Judging</i> | 75 |
| 13. <i>Static Scoring</i> | 75 |
| 14. <i>Flight</i> | 75 |
| 15. <i>Official Flight</i> | 76 |
| 16. <i>RC Flight Plan</i> | 76 |
| 17. <i>Flight Scoring</i> | 77 |
| 18. <i>Official Score</i> | 77 |
| RADIO CONTROL FLIGHT JUDGING GUIDE—SOARING SECTION..... | 78 |
| 19. <i>Mandatory Maneuvers:</i> | 78 |
| 20. <i>Optional Flight Maneuvers</i> | 80 |
| 21. <i>Scale Operations</i> | 81 |
| 22. <i>SCORE SHEETS:</i> | 82 |

RC FIXED WING SCALE GENERAL

NOTE: For FAI events see the FAI Sporting Code.

(The FAI Sporting Code may be obtained from AMA Headquarters upon request. (When FAI events are flown at AMA sanctioned contests the common practice is to only use the basic model specifications and related items such as timing procedures, from the FAI rules. Contest management and procedures usually follow the basic rule structure found in the General sections and specific category sections of the AMA Competition Regulations book.)

1. Applicability

The rules in this section not specifically stated as being for certain events will apply to all Scale events unless an exemption from them is stated in the rules for an individual event.

2. General

A contestant may make only one entry in each scale event unless more are specifically allowed by the event rules. Most events will allow a contestant to enter up to 3 classes at a single event. An AMA Scale event consists of two parts—Static Judging and Flight Judging. Although the criterion for judging differs between the various classes of scale models, the official score invariably includes both static and flight scores. The following is a listing of the scale model classes recognized for AMA competition.

CLASS MATRIX

515 Designer Scale, 522 Team Scale (pilot or builder), 520 Pro-Am Expert
512 Expert Scale, 522 Team Scale (pilot or builder), 520 Pro-Am Expert
522 Team Scale (builder or pilot), 523 Open Scale, 520 Pro-Am Expert
511 Sportsman Scale, 523 Open Scale, 519 Pro/Am Pro (Intermediate)

*All RC Scale Classes must comply with pertinent FCC rules and regulations, in addition to AMA rules. A contestant may only be listed once in a list of winners in each event and may only receive one award in each event.

3. Safety Declaration

At all sanctioned contests, each contestant shall sign an AMA Flight Safety Declaration, attesting to the fact that he or she has previously and is now capable of at least confidently performing in RC Designer, Team, Sport and Pro-Am, a takeoff, a Figure Eight as described in the Scale Flight Judging Guide and a realistic landing within a designated area; in Scale Sailplane competition, a towed or hand-launch, a Figure 8 and a realistic landing within a designated area. Furthermore, the contestant in all Scale events shall also sign a declaration that any and all aircraft he uses in said competition have been successfully test flown prior to the start of competition, including all of the above maneuvers in

applicable events, and are therefore qualified to be flown in the contest, and in the presence of fellow contestants, contest officials, and all others who may be in the flight area during competition.

4. Scale Builder–Flier Rule

Builder of the Model Rule (BOM)

The Builder of the Model Rule applies to the following AMA Scale Classes:

- 511 RC Sportsman Sport Scale
- 512 RC Expert Sport Scale
- 513 RC Sportsman/Expert Combined
- 515 RC Designer Scale
- 522 Team Scale

The Builder of the Model rule is applied to the AMA Scale Classes in this manner:

- 511 RC Sportsman Sport Scale – Builder and flyer are the same person
- 512 RC Expert Sport Scale – Builder and flyer are the same person
- 513 RC Sportsman/Expert Combined – Builder and flyer are the same person
- 515 RC Designer Scale – Builder and flyer are the same person
- 522 RC Team Scale – Builder and flyer are separate individuals. The Builder of the Model Rule criteria still apply to the builder of the plane

The "Builder of Model" shall have satisfied the requirements of RC Sport Scale if the modeler has constructed the airframe from materials and available prefabricated components such as fiberglass cowl(s) and fuselage(s), foam cores, canopy or plastic molded/3d printed exterior details, wheels, etc. Highly prefabricated “composite” and “boned out” models purchased from any source are allowed assuming the builder completes the surface detailing and painting of the model. ARF’s that have been stripped and refinished (Remake) by the builder also qualify. Bind and Fly (BNF), Plug and Play (PNP), and airplanes that have been completed and flown by another modeler do not qualify for BOM classes.

Individuals with permanent physical or mental impairments with limited mobility (requires assistance for safe mobility) can participate in classes that require the BOM. They must actively participate in the construction as well as the finishing of the airplane at a level that is acceptable to their impairment.

Ultimately the Contest Director can make the final call as to what qualifies and does qualify a model for a BOM or team class if there is a question. In the event this occurs, documentation (Separate from that used in static judging) of the work

done to complete an all composite airframe or ARF remake will be helpful in the CD making the final decision.

4.1. Note

The RC Open Scale and the RC Pro-Am Scale events allow use of a prefabricated model, or one built by someone else.

5. *Special Events*

The CD may schedule special events restricted to scale models of specific classifications. (Examples: Event limited to certain engine sizes. Event for multi-engine only. Event for aircraft that flew in World War I. Event for civilian airplanes of a certain time period. Event for quarter scale models, Combined Sportsman–Expert event.) The exact qualification for entry in special events must be clearly outlined in the AMA sanction application and in all pre-contest announcements and publicity.

6. *Profile Fuselages*

Profile fuselages are legal in Pro-Am.

7. *Minimum Flight Score*

All scale entries are required to attempt flight in order to be eligible to place in the competition. A static score alone is not sufficient to qualify. A score of at least one (1) point awarded for flight is the minimum acceptable score. In application of this rule, any model that has become airborne from a takeoff or hand launch will be considered to have achieved at least one (1) flight point, except in the Free Flight events which have minimum flight times for an official flight. Points gained in a taxi maneuver prior to the takeoff run or those that may be awarded for the takeoff run itself during which the model does not become airborne do not count toward satisfying this minimum score requirement. “Airborne” will be held to mean to entirely leave the ground or the hand of the launcher.

8. *Pyrotechnics*

Scale Operations involving pyrotechnics (including, but not limited to, rockets, explosive bombs dropped from models, smoke bombs, all explosive gases and any ground mounted device launching a projectile) are not permitted in Scale competition.

9. *Static Scoring*

Maximum of fifteen minutes is to be allowed for static judging.

10. *RC Equipment limitations*

Any 2.4 radio system available on the market is allowed.

a. There shall be no electronic feedback from the model aircraft to the ground except for telemetry systems that monitor batteries, engines and fuel.

b. The use of any electronic stability device (gyro) on the three primary flight controls is allowed.

Not Allowed:

- a. The use of GPS devices/data or any other satellite based system.
- b. The use of any navigational positioning sensors which provide altitude or heading hold positioning.
- c. pre-programmable devices for flight maneuvers.

**11. RADIO CONTROL SPORT SCALE
(SPORTSMAN AND EXPERT)**

For events 511, 512, 513.

1. General

All pertinent FCC regulations and AMA regulations (see sections titled Sanctioned Competitions, Records, Selection of Champions, General, and Scale General) shall be applicable, except as specified below.

2. Safety Requirements

Consideration of safety for spectators, contestants, and officials are of the utmost importance in this event. Noncompliance with the following safety provisions is cause for disqualification.

2.1.

All models must pass a general safety inspection by the Contest Director or his representatives before flying.

2.2.

In RC, any flying over a controlled spectator area will be cause for immediate disqualification of the flight.

2.3.

Dangerous flying of any sort, or poor sportsmanship of any kind, shall be grounds for disqualification of the contestant involved.

2.4.

All planes entered must have rounded prop spinners or some sort of safety cover on the end of the propeller shaft (such as a rounded “acorn nut”).

2.5.

Knife-edged wings are not allowed.

2.6.

Metal propellers are not allowed for flying.

3. Outdoor Events:

There are no restrictions as to types of power plants that may be used in RC Sport Scale models that are flown outdoors. Reciprocating internal combustion engines (including two-stroke, four-stroke, glow, gas, CO₂, compressed air), electric motors, and turbojet engines are allowed.

3.1.

Turbojet engines up to a maximum of forty-five (45) lbs. thrust, as determined by manufacturer's specifications, may be used, subject to any current AMA safety waivers in effect at the time of the competition.

3.2.

With the exception of electric motors and turbines, the engine(s) must be equipped with an effective muffler or silencer to limit noise output. A tuned pipe is considered a muffler.

3.3.

RC Sport Scale models that are flown outdoors shall weigh no more than 55 pounds, ready for flight, including fuel.

Exceptions to this rule shall include the following:

- a. Turbine powered model aircraft are allowed to a maximum weight of 75 pounds, ready to fly, including fuel.
- b. Propeller powered model aircraft are allowed to a maximum weight of 100 pounds, ready to fly, with fuel.

These exceptions are allowed subject to the restrictions and added requirements, for both aircraft and pilots, which are found within the official AMA 520A, 520B and 520C documents governing Large Model Aircraft. If the event rules to be used vary from those stated in the Competition Regulations for RC Sport Scale event #512, prior permission must be obtained for the rules in order for the model types stated above to compete in the event.

4. Indoor Events:

4.1.

RC Sport Scale models that are flown indoors must be powered with electric, CO₂, or compressed air motor(s). No other type of power plant is permissible for indoor flying.

4.2.

RC Sport Scale models that are flown indoors shall weigh no more than 12 ounces ready for flight, including fuel or batteries.

4.3.

Maximum wing loading of the model, ready for flight, shall not exceed 6 ounces per square foot.

4.4.

Due to wide variations in the size and shape of indoor flying sites, the Contest Director has authority to adjust sections 4.2. and 4.3. as needed to fit the contest flying site and local conditions. In all cases, any deviation from these rulebook specifications must be noted in all pre-contest announcements and literature well in advance of the event.

4.5.

Because of the size restrictions that indoor flying naturally imposes on the flight of a model, the Contest Director has authority to adjust any of the maneuver descriptions in the “Radio Control Scale Flight Judging Guide” to fit the size of his facility. For example, the Judging Guides says that the Fly- Past should be flown between 10 - 20 feet altitude for at least 5 seconds. At many indoor flying facilities that would be impossible. In all cases, any deviation from the Judging Guide maneuver descriptions must be noted in all pre-contest announcements and literature well in advance of the event.

5. Model Requirements

A scale model shall be a replica (copy) of a heavier-than-air, fixed wing aircraft. Only prototype aircraft that actually made flights can be selected as subjects for competitive modeling. “Penguin” ground trainer types not meant to leave the ground, proposed designs, mockups, and actually constructed functional aircraft that were never test flown cannot be used. The Contest Director may disqualify any entry which, in his opinion, is not a bona fide scale model. Enlargement of wing and tail area, changes in dihedral angles, changes in landing gear placement, simplification of structure, etc., are permitted, but with appropriate deductions

during scale judging. Extreme deviations from scale dimensions, particularly those which noticeably alter the resemblance of the model to its prototype, will be heavily penalized. Models which only simulate scale appearance by component shapes resembling a prototype aircraft, but whose basic design bears no relationship to it, are not permitted. The preceding sentence does not necessarily rule out profile fuselages unless other parts of the model are also non-scale. The scale judges will apply appropriate downgrading of scores for the non-scale fuselage cross-section of the profile fuselage and for the appearance. If the pilot is visible in flight in the prototype aircraft then a man-shaped dummy pilot of scale size and width must be visible in the model during flight. The dummy pilot figure will not be scored or considered in any way during Scale Judging. If the contestant wishes, he may present his model for Scale Judging without the pilot figure in place, and no downgrading will be done by the judges if he does so. The contestant will be allowed only one (1) entry in RC Sport Scale. At any one (1) contest, this entry may not also be entered in RC Pro-Am, Designer Scale, or Team Scale, although separate models may be entered by the same contestant in these events.

6. Proof of Scale

To prove that the model resembles a particular prototype, some proof of scale material is required.

6.1.

Proof of Scale is the responsibility of the contestant.

6.2.

To be eligible for Accuracy of Outline points, one (1) of the following must be provided by the contestant:

Either: a. A three-view drawing (line, tone or color). Drawings with more than three (3) views are also acceptable. The three-view scale drawings must be from a reliable source such as the aircraft manufacturer, model or aviation magazines, books, etc. Commercially available three-view drawings are acceptable. Plans of non-flying solid or replica models, either kit or magazine, are acceptable. Homemade or non-published drawings, corrected three-views, or drawings of flying models are not acceptable unless approved in advance by an authoritative source such as the AMA Technical Director, a

Scale Contest Board member, the manufacturer or builder, or other competent authority. Suitable photos, historical background, and supporting data must accompany the drawings submitted for approval to permit verification.

Or: b. A selection of photos of the aircraft modeled, sufficient to show the outlines of the aircraft in side view, front view and plan view. The photographs need not be taken from directly overhead or at exactly 90 degree angles to the side or front of the outlines but can be pictures taken from oblique angles which allow the judge to interpret the outlines.

Or: c. A plastic model of the type available commercially, unmodified and unpainted may be used. The use of a plastic model as proof of Accuracy of Outline will require the deletion of two (2) 8-1/2" x 11" pages or their equivalent as provided for in paragraph 4.5, below.

The contestant may furnish a three-view, set of photos or an unpainted, unmodified plastic model—or any combination of these items—for Accuracy of Outline judging if he desires, but he is not required to furnish all or any two (2) of them. No downgrading of the Accuracy of Outline Score will be done by the judges if only one of the above listed items (a, b or c) is provided and not either of the others.

6.3.

To be eligible for Finish, Color, and Markings points, some proof of the color scheme used on the model is required. This can be:

Either: a. Photo or photos.

Or: b. Some other pictorial representation, such as a magazine or other published color painting or drawing.

Or: c. A detailed written description of the color scheme and/or markings from a reliable source.

Or: d. Notes and diagrams of markings on black-and-white three-view. (“Profile” and similar types of color paintings in three-view form can be used for both proof of Accuracy of Outline and Finish, Color, and Markings.) The contestant may provide a photo(s), pictorial, written or three-view notes on color and markings or any combination of these items—for Finish, Color, and Markings, but he is not required to furnish all or any two (2) of them. No downgrading of the Finish, Color, and Markings score will be done by the judges if only one of the above listed items (a, b, c, or d) is provided and not either of the others. If color chips are provided to prove color, all colors used on the aircraft must be represented. Color chips must be from a published source and not produced by the contestant. If both color chips and color photos are included in the documentation, the contestant must specify in the documentation which is to be used for color judging. If not specified, the color photos take precedence.

6.4.

If no proof of Accuracy of Outline accompanies the model, no points can be awarded for Accuracy of Outline. If no proof of Finish, Color, and Markings accompany the model, no points can be awarded for Finish, Color, and Markings. Points for Craftsmanship and Flight may still be awarded, even if one or both of the requirements for proof of Accuracy of Outline and Finish, Color and Markings are not complied with. It is not the intent of the documentation rules to limit the choice of scale subjects only to those aircraft for which a large amount of data is easily available or penalize the use of rare color or markings schemes. In many cases it is not possible for the builder to provide enough photos of the same plane to cover all aspects of color or markings. In these cases no downgrading will be made for lack of proof of the “other” side, or bottom, etc. or use of written proof of color in lieu of color photos or drawings.

6.5.

To facilitate rapid judging, Sport Scale documentary presentations are limited to no more than eight (8) pages (one (1) side) sized 8-1/2" x 11" or an equivalent area of some other arrangement. “To facilitate rapid judging, up to three (3) sets of the same three-view used as documentation may be provided by the contestant and will only count as one (1) page in the documentation presentation.” Three-views larger than 8-1/2" x 11" or more than one (1) page are permitted and will also count as one (1) page of the eight (8) allowed for documentation.

7. Static Judging:

7.1.

Static judging shall be done at a distance of 15 feet from the model. It is recommended that two (2) lines 15 feet apart be established. The model is then placed behind one (1) line with no portion allowed to intrude into the 15-foot space. The judges will remain behind the other line during the judging. The owner of the model or a contest official, at the discretion of the modeler, other than the judges, will then rotate or move the model to positions requested by the judges in order to see all views of the model. The model may be placed on a table if desired.

7.2.

The judges will not pick up or examine the models closely before or during the judging. This rule is not intended to prevent display of the entries before or after judging for the benefit of spectators. The models may be displayed on the contest flight line, in a scale cage or whatever other area the Contest Director wishes to designate.

7.3.

Cockpit and cabin interiors, even if partially visible from the judging distance, are not to be considered in scoring the model. All other visible features will be considered.

7.4.

Subjects having un-cowled radial engines or configurations whose shape does not provide sufficient space such as the Spitfire, P-63, etc., or nose or cowling sizes dictated by the scale to which the model has been built, which do not lend themselves to any practical method of completely concealing a standard type model engine, will not be downgraded in scale judging, when, of necessity, part of the engine must be exposed or non-scale openings are made for engine cooling. In the case of the required muffler installation, no scoring penalty of any kind will be applied by the judges, either for a protruding or fully exposed muffler or for the hole in the cowl or fuselage necessary for attachment of the muffler or silencer to the engine.

7.5.

No changes shall be made between judging and flying which alter the scale appearance of the model except as noted below.

- a. A flying propeller of any diameter and color may be substituted for a scale propeller for flight.
- b. The propeller spinner used in flying must be a similar size, shape and color as the one presented for scale judging except that it may have a different number of cutouts appropriate for the flying prop. The nose of the flying spinner may be rounded to comply with the safety regulations. The flying spinner must be presented to the judges during static judging. If the flying spinner varies significantly from the static spinner, the model must be static judged with the flying spinner installed on the model.
- c. A radio antenna of any type may be added.
- d. Models of seaplanes or flying boats are permitted to use non-scale devices or dollies for takeoff in the absence of suitable water conditions. If dollies are used they must not be attached to the model in flight. Deviations from scale through the inclusion of permanently mounted, recessed wheels, skids, plug-in removable landing gear or similar devices, if neatly and inconspicuously executed will not be penalized in the scoring of Accuracy of Outline points.

- e. If bombs, rockets, drop tanks, etc., are to be dropped or released, they must be in place at the time of judging. The bombs or other armament in place at scale judging may be replaced during flying if the replacements are the same size, shape, and color as those submitted for scale judging. Static judges will make note on the static judging sheet of all observed droppable stores in place on the model at the time of static judging.
- f. Sharp pitot tubes projecting from the wing or fuselage will be removed before flight as a safety consideration. No downgrade will be made to the flight realism score.
- g. Where a model is equipped with a tailskid and the takeoff surface is paved, a tail wheel may be added, for flying only, to assist ground controllability. This wheel may not be added where a grass takeoff surface is available to the contestant to use if he chooses.

8. Static Scoring

100 points maximum may be earned as follows:

| Category | Points |
|---|------------|
| Accuracy of Outline (General Impression) | Maximum 40 |
| Craftsmanship | Maximum 30 |
| Finish, Color and Markings | Maximum 30 |

9. Flight

9.1.

It is suggested that Scale Judging take place before official flights. If this is not possible or desirable, the Contest Director may hold part or all of the official flying before Scale Judging. Any damage caused to the model by flying before Scale Judging will be disregarded and not counted against the contestant. There is no maximum limitation of the number of official flights allowed during the time scheduled for the event, but a minimum of three (3) rounds should be scheduled.

9.2.

All flights shall be ROG unless the Contest Director certifies that ground conditions do not allow this, in which case hand launch may be used. Model configuration and ground conditions may also make hand launches impractical. Where site conditions and flight line safety can still provide for takeoff and landing despite poor ground or wind conditions, the

landing and takeoff may become optional in score for flight schedule and other maneuver options selected as their replacement prior to flight. The CD may also certify this option for tail skid aircraft (such as WW- 1) or any aircraft prior to a contest for a variety of known site conditions or limitations. When used, each added replacement maneuver will be allowed one extra minute for total allowed flight time. The CD will specify right hand or left hand pattern, whichever carries maneuvers away from the spectator area. Such maneuvers as the procedure turn, figure eight and landing approach pattern will thereupon be flown to the left or to the right of the path of straight flight out. If a hard surface and grass runway are both present at an event of contest the pilot will have the option of taking off on the surface of choice and landing on the other. Example: pilot takes off on grass and land on hard surface runway or vice versa.

9.3.

Time limit for each flight is 12 minutes inclusive of starting engine(s).

9.4.

A flight is considered official when an attempt is made, whatever the result. There is an attempt when:

1. The model becomes airborne.
2. The model fails to commence the takeoff maneuver within the 12 minutes allowed for each flight.
3. Personal contact is made with the model after it has become airborne.

9.4.1.

An official flight is considered complete when any of the following occur:

- a. The time limit expires.
- b. Personal contact is made with the model for the second time after the model has been released for takeoff during an official flight.
- c. The pilot has called “Flight Complete/Finished.”
- d. Landing maneuver is complete if not followed by another maneuver in the flight plan.
- e. Disqualification for any reason.

9.5.

Once airborne, no person, other than the pilot, shall operate the transmitter controls. Operation by anyone else shall require disqualification of the entire flight.

10. RC Flight Plan

The RC flight plan shall consist of 10 maneuvers and/or scale operations, five (5) mandatory and five (5) optional. The mandatory items are unassisted ROG, figure eight, fly past, landing, and realism in flight. The mandatory and optional maneuvers may be performed in any sequence, but must follow the flight plan presented to the flight judges. Any maneuver and/or scale operation may be selected for scoring only once during any single official flight.

10.1.

Options may be any maneuvers listed in the Scale Judging Guide or any Scale Operations (retract gear, flaps, bomb drops, crop dusting, etc.) typical of the aircraft modeled. No more than two (2) Scale Operations may be selected, not including the multiengine option, if used. Maneuvers and Scale Operations must be listed on the judging form before flying. The contestant may be asked to prove that his selection of maneuvers and operations have actually been performed by his prototype aircraft.

10.2.

Touch-and-Go (maneuver) shall be counted as two (2) options on the flight plan, replacing two (2) other maneuvers or scale operations.

10.3.

At the option of the CD, the contestants may be requested to demonstrate on the ground any Scale Operation that may be difficult to see in flight (i.e., retract gear speed, flaps, lights, etc.). The contestant may elect to demonstrate them even if the CD is not requiring a demonstration. These options need not to be demonstrated again in flight during a flyby (although the contestant may elect to do so if desired), but must be used in flight in the same manner as the prototype.

10.4.

The contestant may select different options in succeeding flight rounds, at his choice. Different options must be cleared as “prototypical” by the CD.

10.5.

Any scale maneuver and/or scale operation not capable of being performed by the pilot in the subject aircraft during taxi or flight is not an eligible option.

11. RC Flight Scoring

Maximum total flight score is 100 points.

11.1.

All maneuvers and scale operations (except Touch-and-Go) are to be scored from zero (0) to 10 points to the nearest half point.

11.2.

Touch-and-Go, which counts as two (2) options, is scored from zero (0) to 20 points.

11.3.

No maneuver or scale operation will receive an automatic maximum score. All will be judged in relation to their scale-like qualities.

11.4.

In the event one (1) or more engines of a multiengine model fails during flight, the multiengine score will be based on the contestant's ability to continue flight and according to the multiengine option description. The contestant will continue to receive flight points for each maneuver or operation completed.

11.5.

Each flight should be judged by at least two (2) judges, with their scores averaged to give a final score for the flight. It is suggested that each maneuver be scored immediately after it is performed. Judges shall score maneuvers individually and without any consultation between them. There should be enough judges available to establish a rotational procedure which will average out variations in judging.

12. RC Sport Scale Classes

RC Sport Scale events shall be divided into three (3) classes requiring different competitive experience. They shall be referred to as Sportsman, Expert, and Designer classes.

12.1.

A contestant may enter the Expert class at his own option, but once entered in this class he may not again compete in the Sportsman class. A contestant must enter the Expert class if he has accumulated 30 advancement points. Advancement points are awarded as follows: Each contestant in any AMA Class A or higher rated Sport Scale or Designer Scale contest receives one (1) advancement point for each other contestant he places ahead of.

Examples:

1. A person enters a contest of 15 entries and places fifth. He receives 10 advancement points. He enters a contest of two (2) entries and is second. He receives no advancement points. He enters a contest of 25 entries and wins. He scores 24 advancement points. His total is now 34, and he must enter Expert from now on.
2. A person enters the National Championships and places sixth out of 57 contestants. He receives 51 advancement points and must enter Expert from now on.

12.2.

All other contestants may enter the Sportsman class.

12.3.

The Contest Director may hold a combined Sportsman–Expert class event if he so states on the contest sanction application and in all pre-contest publicity.

12.4.

Contestants shall be responsible for keeping a record of advancement points earned. Record cards are available from AMA Headquarters.

13. Official Score

“The official score shall be the total static points (100 maximum) and the average of the two (2) best flight scores (100 maximum). To break a tie, the best single flight will be added to the static score. If this does not break the tie, add the average of the three (3) best flights to the static score. If this does not break the tie then add the average of the four (4) best flight scores to the static score. If only two (2) rounds are flown, then the official score will be the total of the static points (100 maximum) and the best single flight score (100 maximum). To break a tie if only two rounds are flown, add the average of both flights to the static score”

RADIO CONTROL DESIGNER SCALE

For event 515.

The rules for this event are identical to Expert Sport Scale, event 512, except as noted below.

1. Eligibility

Only those models that are the original design of the contestant are eligible for this event. Models that are built from kits or commercially available construction plans, modifications from kits or plans, or scaled commercial plans, are not eligible.

2. Craftsmanship

Craftsmanship judging will be done at zero distance.

RADIO CONTROL PRO-AM

For event 520.

The intent of Pro-Am is to provide an RC scale event which is, and is to remain, simple in concept. There are two divisions of RC Pro-Am. Pro-Am Sportsman Division is for the novice contestant only. This is purely an ENTRY LEVEL division for RC scale competition. Pro-Am Pro Division is open to any contestant with previous RC scale competition experience. There are two Divisions within Pro-Am Pro.

1. Pro-Am Pro Division 1:

For aircraft where the prototype that's been modeled has fixed gear, has no more than one mechanical option or was not designed specifically for racing. (Basically, fabric covered).

2. Pro-Am Pro Division 2:

For aircraft where the prototype that's been modeled has retracting landing gear, has more than one mechanical option or was designed specifically for racing. (Basically, metal skinned).

3. Eligibility

The contest is open to modeler-built or factory-built RC scale models. There are no minimum size, weight, or power limits. The maximum weight and displacement limits are the same as for RC Sport scale, General. rule 4 (builder-flier) will not apply in this event. With advance notice, the event may be conducted in different classes based on skill or age level, i.e., Open, Entry, Junior, Senior, etc.

4. Static Judging

Static score will be zero (0) or five (5). Five (5) static points will be awarded to contestants who show documentation of outline and color resembling the subject

aircraft, or similar aircraft of the era. Published 3-views, with or without color or markings, or box top renditions, are acceptable for documentation. Color and markings do not have to be specific to the model presented. That is all that is required to receive the static points.

5. Flying

All rules as per RC Sport Scale (event 512) except contestant may use only one mechanical option for scoring.

6. Scoring

Contestant's score shall be the average of his best two (2) flight plus the five (5) static points if earned.

RADIO CONTROL TEAM SCALE

For event 522.

The rules for this event are identical to Expert Sport Scale, event 512, except as noted below;

1. Eligibility

The team will consist of the builder of the model and the pilot-flier.

2.

The model's construction may also be a team effort, i.e. the pilot/flier may be involved in the building.

3.

The builder of the model must be listed as one of the team and must be present.

RADIO CONTROL OPEN SCALE

For event 523

The rules for this event are identical to Expert Sport Scale, Event 512, except as noted below:

1. Eligibility

This event is open to any modeler built, purchased built or factory built RC Scale model. There is no "builder of the model" that must be present to participate.

2. Classes

With advance notice, the event may be conducted in different classes based on skill or age level, i.e., Open-Expert, Open-Novice, Open-Junior, Open-Senior etc.

RADIO CONTROL SCALE FLIGHT JUDGING GUIDE

1. Purpose

To furnish uniform guidelines for executing and judging flight maneuvers and scale operations of model aircraft, which are within the capabilities of their full scale counterparts and will be performed during the flight presentation of the RC Scale events held in accordance with the AMA Official Model Aircraft Regulations.

The guide is intended to inform a contestant what is expected from his flight presentation in addition to providing the flight judges with a uniform method of rating the flying performance of an entrant's model in both the mandatory and optional maneuvers and scale operations that make up the flight presentation.

2. Principles

The principles of flying or judging a scale model at a contest held in accordance with AMA rules should be based on the perfection with which the model simulates the flight performance of its full-scale counterpart. It is recognized, however, that while the contestant is able to go to some length to research the flying characteristics and capabilities of the aircraft he modeled, the same cannot be done by the judges. They may be confronted by many models of aircraft with which they are unfamiliar. It should, however, be obvious to all concerned into what basic category the model should be placed, i.e., maneuverable fighter or sedate transport. Since flight realism is a major factor in the award of points, judges with full-scale flight experience are desirable. This may not always be possible and at many contests the same judges may be required to judge both pattern and scale flying events. If such is the case, it is recommended that prior to the contest date, the judges should meet and discuss the differences in judging scale versus pattern modes as outlined in this guide and the AMA Pattern Judges Guide.

The criteria to be used in judging the flight of scale models may be divided into three (3) categories, Precision, Presentation, and Realism as follows.

3. Precision

When the contestant announces a maneuver, the judge should form a mental picture of the flight path to be followed by the model. The size of the maneuver will be dependent on the type of aircraft modeled and will be discussed under Realism. Judging begins at the time the contestant announces, usually with words such as "beginning now," and continues until, in the judge's mind, the maneuver is complete. Course corrections, not called for in the description of the individual maneuver, but which are obvious to correct deviations in the path of the model after beginning the maneuver, shall be a cause for the deduction of points due to lack of precision.

Smooth and unobtrusive corrections during a maneuver to counter wind drift should not be a cause for loss of points if they are executed in a manner typical of the prototype aircraft.

A contestant should note that in order for a judge to obtain some reference for the maneuver being executed, the start and finish of the majority of maneuvers should be level flight. In the case of models of light aircraft, in which insufficient power would prevent vertical maneuvers to begin from level flight (loop, Immelmann, etc.), a dive may precede the maneuver. No points shall be deducted if a contestant announces his intention to build up speed in a dive prior to the start of a maneuver. At the start and finish of all maneuvers the wings of the model should be level.

4. Presentation

To achieve perfection, all flight maneuvers should be presented in a manner such that they can be easily judged. The optimum location of the maneuver relative to the judges will vary according to the type of maneuver executed. For example, maneuvers with horizontal symmetry

(Cuban Eight, loop, roll, etc.) should have their midpoint or center immediately in front of the judges. Some maneuvers, however, are best performed offset to the right or left of the judges to present a clear view of the model as it performs, say, a stall turn or a wingover. It goes without saying that the contestant should locate himself near the judges so that they all obtain similar views of the flight presentation.

In addition to presenting the maneuvers for maximum visibility, the longitudinal distance from the judges should not be excessive. Generally, the contestant should strive to center a flight maneuver at a horizontal distance no greater than 300 feet from himself. It should be noted that, in the descriptions of individual maneuvers, some are required to be flown down the center of the runway. However, for safety when a narrow runway is used, the Contest Director may specify the far edge of the runway as the line over which these maneuvers should be flown. Judges should downgrade a contestant whom they suspect is trying to cover up poor flying ability by a performance made at an excessive distance. The actual distance at which an individual contestant chooses to perform his maneuvers should take into account the altitude of the model when at its highest point in the maneuver. High altitudes, close to the transmitter, that force the judges to look up at more than a 45-degree angle, should be avoided. Aside from the discomfort endured by a judge who is forced to look in a vertical or near vertical direction, the perfection of the maneuver cannot be properly assessed from such an angle. No bonus points will be awarded for a low altitude presentation, but points will almost certainly be deducted for excessively high presentations.

Contestants should bear in mind that the judges spend many hours on the flight line, and a painful neck, caused by looking overhead at maneuvers, will almost automatically result in downgrading.

Another point that the contestants should bear in mind is to avoid crossing the sun with the model during a maneuver, if at all possible. Even a zero (0) score is completely justified if, in the judge's opinion, the maneuver could have been placed elsewhere.

5. Realism

Awarding points for realism during the flight maneuvers is probably the most difficult and controversial aspect of judging scale models. The presentation of a realistic flight by a contestant should be given some attention prior to the contest. Most important is to only perform flight maneuvers that were capable of being performed by the prototype aircraft. For example, three (3) axial rolls performed by a model of a B-29 may well be spectacular, but it should receive a zero (0) score for being outside the capabilities of the aircraft. To eliminate discord on the flight line, it is recommended that, prior to flight, any maneuver or scale operation not listed in the rule book should be cleared by the CD. The contestant should be prepared to explain any such maneuver or operation and, if necessary, supply documentation that such were indeed within the capabilities of the aircraft.

The size of the aerobatic maneuvers performed by a contestant should reflect the capabilities to the aircraft modeled. For example, it would be expected that a loop performed by a J-3 Cub would be smaller in diameter than one performed by a P-51 Mustang if both were modeled to the same scale. The speed at which such maneuvers are performed should also reflect the capabilities of the prototype.

Consideration should also be given to throttle position during aerobatics. In many of full-scale prop driven aircraft, power must be reduced at the point of maximum altitude in a vertical maneuver before entry into the descent portion. Execution of such maneuvers by a model at a constant full throttle, which should be obvious by the sound of the engine, should be grounds for a reduction in score.

The size of a maneuver will also be influenced by the physical size of the model. Models scaled at one (1) inch = one (1) foot would be expected to perform aerobatic maneuvers such smaller in overall size than a similar model scaled at, say, three (3) inches = one (1) foot. Consideration should be given in all aerobatic maneuvers to the forces that would be exerted on the full-scale counterpart. Exceedingly small or tight maneuvers with unnecessarily high rates of roll, pitch or yaw do not simulate the

performance of the majority of full-scale aircraft and should be downgraded accordingly.

Finally, the contestant should acknowledge that the smoothness or gracefulness of the flight presentation will have a large impact on its realism. Sudden jerks and attendant changes in heading should be avoided unless the contestant is willing to prove that such motions were characteristic of the prototype when it performed that maneuver. These motions would represent high “g” forces, perhaps exceeding the full-scale tolerances, and the judges are justified in downgrading for them unless they can be shown to be typical of the full-scale aircraft’s performance. Similarly, the transition from ground to air and vice versa during takeoff and landing should be smooth. The judge should consider himself to be a passenger in the model and assess these maneuvers in terms of the effect they would have on his well-being. Many of the so called “average” landings by RC models would result in collapsed landing gear in a full-scale aircraft or, at the very least, severe bodily discomfort to any passengers.

6. Accurate and Consistent Judging

The most important aspect of consistent judging is for each judge to establish his own standards and maintain them throughout the meet. It is recommended that the Contest Director or Chief Judge should hold a meeting prior to the day of the contest to discuss with all the flight judges the rules for the event. Any standards of judging or interpretations of rules presented to the judges which differ from or are additional to guidelines or rules presented in the Competition Regulations book should also be presented to the contestants in a pilots meeting. It is also advisable that, in order to make the judging standards as uniform as possible, a non-contestant should perform a judges’ practice flight immediately prior to the first official contest flight. All judges should score this flight simultaneously and privately. After the flight, the defects in each maneuver should be discussed, and an agreement should be reached on the severity of the defects and the appropriate number of points that should have been deducted. When this is done, and the contest has begun, individual judges should strive to maintain a uniform standard of judging for all contestants.

As is stated in the rules, a contestant who flies over a controlled spectator area will be disqualified (receive a zero (0) score) for that flight. Such spectator areas must be clearly defined by the CD in a briefing prior to the start of the flying portion of contest. It is also recommended that a “foul line” should be established, which can be the edge of the active runway, nearest to the flier, extended to infinity in either direction. Any flying over this foul line should be grounds for a zero (0) score in the maneuver in which it occurs. The judges should all agree on such an occurrence, and if a separate person is used as the flight timer it is recommended that he or she be assigned the task of determining when a

model crosses the foul line or passes over a controlled spectator area. Unanimity in awarding zeros for unsafe flying practices should always be reached. Nothing can cause more unrest among contestants than a zero (0) and a seven (7) score for the same maneuver. The responsibility for disqualification of a contestant who persists in flying in an unsafe manner rests with the CD.

7. Judging Individual Scale Operations and Flight Maneuvers

In addition to the obligatory flight maneuvers, a contestant must perform several options which may be any scale operation or maneuver that was typical of the prototype aircraft. A variety of scale operations and maneuvers are described in this section of the guide; however, a contestant may select an operation or maneuver of his own choice. Should this be the case, a written description should be submitted to the chief judge prior to flight time. The Chief Judge can then inform all judges how this option will be performed and judged. As in the case of all options, the contestant should be prepared to prove that his choice was typical of the prototype aircraft.

A judge should not wait until a maneuver is completed before trying to assign a grade based on overall impression. Judges should assume that a contestant is going to perform a perfect maneuver and should therefore start with a grade of 10 points. As the maneuver is executed, any faults that are observed should be the cause of a lesser number of points to be awarded. Full marks should only be given when a maneuver is ideally positioned, and no faults are observed. This is not a common occurrence.

In downgrading the score for an individual maneuver, or a scale operation, a judge should consider the number of defects, the severity of the defects, and the number of times any one defect occurs. For example, a single change in heading during takeoff would be considered one defect, while two (2) or three (3) distinct turns would be considered two (2) or three (3) defects. In a case where more than 10 defects are observed it is not possible to downgrade one (1) point per defect or we might have several negative scores. While a minor defect may result in the loss of less than a full point, a major defect could be the cause for the loss of four (4) points. Unless a maneuver is missed or is totally unrecognizable, a zero (0) score should not be given.

1.1. Description of Scale Operations

1.1.1. Multi-engine

To obtain maximum points the engines should be of equal displacement unless the engines of the prototype differ in size or type. In this case, the model engines should differ in a similar proportion. Extreme variation from scale engine sizes should be heavily penalized. Proof of scale engine sizes shall lie with the contestant. For maximum points all engines must be running at takeoff and continue throughout the flight with throttle operation

being demonstrated at least during the approach and land. There should be no requirement to perform additional fly-pasts to exhibit multiengine operations unless the competitor wishes to demonstrate differential throttle operation and which may be claimed as a separate option. In any case of loss of an engine during flight, safe flying practices should take precedence over trying to remain airborne merely to score points.

Errors: Engine or engines stop during flight. Throttle operation not demonstrated in the approach and landing. Multiengine model has engines which differ in size in a ratio not typical of the prototype.

1.1.2. Retract and Extended Gear

Retraction should commence during the takeoff maneuver when the model establishes a positive rate of climb. Gear extension should be initiated during the downwind leg of a traffic pattern. The speed of gear operation and its action should approximate that of the prototype. For example, “snap action” gear should be downgraded, but the model should not be expected to duplicate the

cycle time of the prototype. Similarly, if on the prototype the gear folded inward (towards the aircraft center line), points would be deducted if on the model the gear folded outward. Models of aircraft with retractable tail wheels should be downgraded if the tail wheel of the model does not retract. If the judges cannot observe the gear retraction sequence due to the attitude of the model at takeoff, they may request that the gear be cycled during a fly-past.

Errors: One (1) or more gear leg fails to retract or extend (includes tail wheels if these were retractable on prototype). Gear sequence is less than two (2) seconds. Gear action is grossly different from prototype. Gear extends or partially extends during high positive “g” maneuvers. One (1) or more gear legs collapse during landing due to a cause other than a hard landing.

1.1.3. Flap Operation

A contestant may elect to use flaps for takeoff, but no points shall be deducted if they are not used. Flaps should be used during maneuvering if this was a feature of the prototype. Flaps must be used for landing if they are claimed as an option. For maximum points flaps should be lowered on the final crosswind leg of a traffic pattern. Flaps should also be used during a touch-and-go or overshoot and points should be deducted from both the flap option and the maneuver if the contestant fails to use them. There should

be no loss in points if the judges fail to observe the flaps in motion during flights. If, however, they are small in size and difficult to observe in a lowered position, the judges may request that they be lowered in a taxi maneuver prior to takeoff or that they remain lowered in a taxi maneuver after landing. For maximum points the flap action should resemble the prototype, i.e., split flap, fowler flaps, etc. Only if it is agreed by the judges that the wind strength is too great to justify flaps during a landing should a fly-past be required to demonstrate flap operation.

Errors: Failure to operate flaps when required. Flap operation is grossly different from prototype. Model exhibits violent trim change during flap operation.

1.1.4. Bomb Drop

Bombs should be carried in the same manner as the prototype. For bombs carried internally, bomb bay doors should open, bombs should drop, and doors should close for maximum score. If bombs are carried externally, they should be securely attached with no noticeable oscillation in the slipstream. For maximum score the model should perform a bomb run in the manner of the prototype.

Unusual bombing techniques may be used if the contestant can verify them with written documentation. With the exception of napalm types, bombs should not tumble end-over-end after release. A contestant is permitted to substitute a different bomb or bombs for the flight presentation than was displayed on the model during static judging provided that the size and shape is similar. When the bomb drop option is selected, the bombing run is a demanded part of the option and may not be claimed as a separate or additional option.

Errors: Bombs are not carried in the manner of the prototype. Bomb doors are grossly different in operation from prototype. Bomb(s) drop immediately upon opening of doors. Bomb drop not preceded by a bomb run. Finned bombs tumble erratically after release. Externally mounted bomb(s) wobble(s) in slipstream during flight prior to release.

1.1.5. Torpedo Drop

For maximum points a torpedo drop should be performed as a part of a torpedo run at a low altitude. Actual altitude of the model at release would depend on its scale, but it should be low enough to enable the torpedo to strike the ground in a relatively flat attitude. Release should be performed with the model in a level attitude and may be followed by a rapid climb which may include a turn. The

actual procedure to be followed should be announced to the judges prior to performing the operation.

Errors: Model is too high at release. Release is not preceded by a straight run. After release model performs unannounced maneuvers.

1.1.6. Tank Drop

A fuel tank capable of being jettisoned should be carried in the manner of the prototype. The drop should be performed with the model in level flight in clear view of the judges.

Errors: Tank not securely attached to model, has visible oscillation in slipstream prior to release. Tank does not fall clearly away from model at release. Model not in level flight at release.

1.1.7. Parachute Drop

A parachute drop or ejection should be performed in the manner of the prototype. Cargo should be dropped via doors, hatch, bomb bay, or from wing mounts. A man or men should be dropped via doors, hatch (if the aircraft was so equipped), or by inverting the model. A single seat aircraft must not drop its pilot. A braking parachute may be deployed on landing if this was a feature of the prototype.

Errors: Parachute does not open. Parachute does not fall clear of aircraft. Braking parachute rotates after deployment and tangles its rigging lines. Parachute is emitted from the aircraft in a manner not typical of the prototype.

1.1.8. Agricultural Spraying or Dusting

This scale operation is for models of aircraft used for crop spraying or dusting only. The contestant should be prepared to document that the prototype aircraft was used for this purpose. Since the manner in which this operation was performed by full scale aircraft may differ according to aircraft type and/or crop being covered, the contestant should describe to the judges his intended presentation. Generally, the aircraft will make a low pass down the runway centerline and visibly perform its spraying or dusting mission on command by the contestant. An emergency dump of the hopper contents may be performed and may be accompanied by a rapid climb to simulate avoidance of an obstacle. The maneuver should begin and end on the same heading and with the wings level.

Errors: Model does not release visible spraying/dusting material. Maneuver is not presented in full view of the judges. Model follows erratic course during the operation. Model changes heading during operation.

1.1.9. Other Optional Demonstration

A contestant may elect to perform a scale operation of his own choice that was typical of the prototype. Any such operation must be cleared by the Contest Director and explained to the judges before flight.

1.2. Description of Mandatory Maneuvers

Following is a list of the mandatory maneuvers that must be performed in the RC Sport Scale and Giant Scale events.

1.2.1. Takeoff

The model should remain still or near still (according to whether the prototype had brakes) on the runway with the engine running

after release by contestant or a helper or after a taxi maneuver. The

propeller will not stop before the takeoff run commences. Takeoff should be into the wind and should begin with a straight ground run followed by a gentle liftoff with a climb angle consistent with that of the prototype. Aircraft with conventional (tailwheel) gear might swing as the tail rises. Such swing must be corrected promptly with no loss of points. Takeoff is completed when the model is approximately 10 feet from the ground. For maximum points, the model should use any scale operation that was required by the prototype to perform its normal takeoff. Retractable gear, if equipped, commences as soon as positive rate of climb is established.

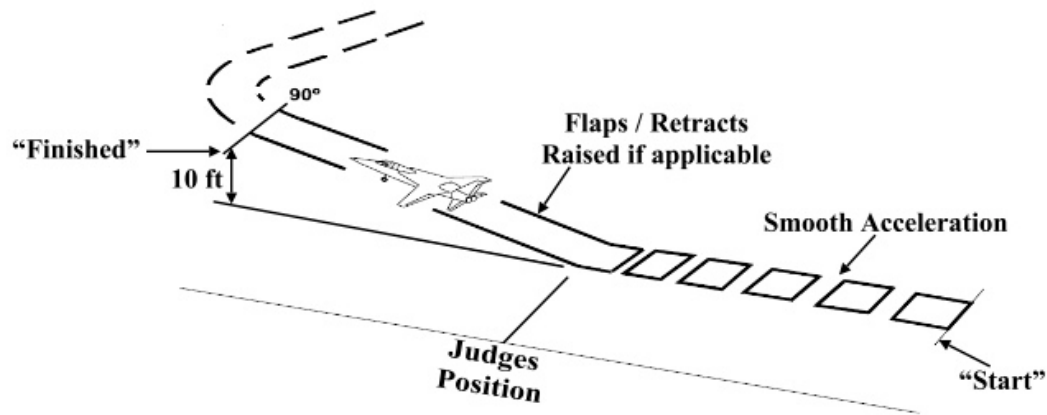

Errors:

- Pilot or helper holds model after advancing the throttle to takeoff power.
- Electric powered propeller stops before takeoff run commences.
- Model swings on takeoff
- Model becomes airborne too soon.
- Takeoff run is too long.
- Model jumps off ground.
- Model climbs too steeply after takeoff.
- Model drops a wing badly during takeoff (should not be confused with aileron correction for crosswind).
- In the interest of safety, a takeoff may be aborted and restarted with a seven (7) point or 70% of maximum score on the first retry (and 70% for each subsequent retry) rather than given an automatic zero (0). For example, the maximum score that could be given would be seven (7) points after the first abort and first retry, the second retry after another abort is five (5) points (70% of 7), the third retry is 3.5 points (70% of 5), etc. The contestant is still on the clock for each retry.

1.2.2. Figure Eight

This maneuver demonstrates pilot control of the aircraft. The model approaches in straight and level flight on a line parallel to the flightline, then a 90-degree turn is made in a direction away from and to the judges, followed by a 360-degree turn in the opposite direction, followed by a 270-degree turn in the first direction, completing the maneuver directly centered on the judges, on the original approach line and at the same altitude as entry. The intersection (midpoint) of the maneuver shall be on a line that is at a right angle to the direction of entry, centered on the judges, and at the entry altitude.

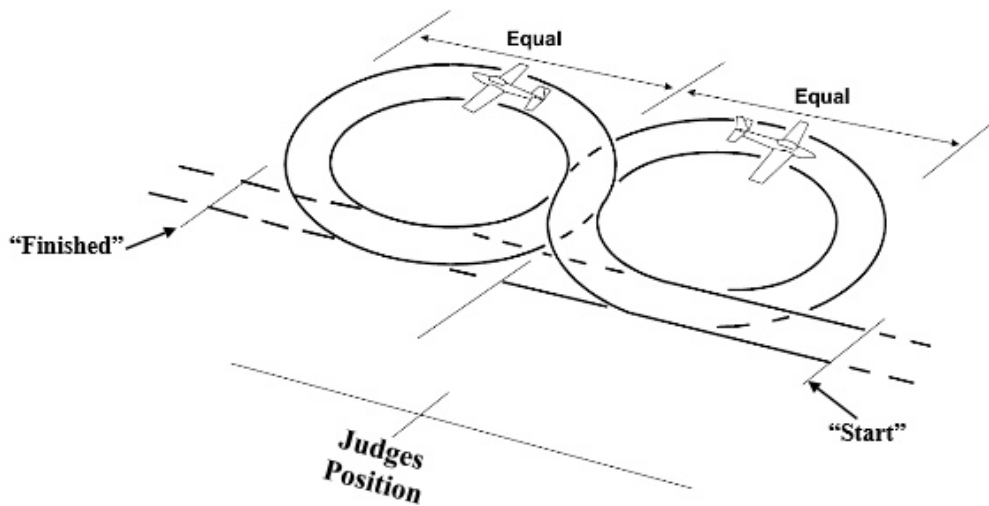

Errors:

- Entry not made parallel with spectator line.
- Rate of turn not constant in any half circle.
- Circles not same size.
- Model does not maintain constant altitude.
- Model does not complete 270-degree turn at point where first 90-degree turn was started.
- Finish not on the same heading or altitude as entry.
- Model does not begin and end in level flight.

1.2.3. Fly-Past

The model shall fly straight along a path parallel to the runway that is over the far edge, the edge away from the spectators, at an altitude of between 10 and 20 feet. The model shall be flown at the fly-past altitude for at least five (5) seconds. The midpoint of the maneuver should be opposite the judges. If a very wide runway is used, such as may be the case at an airport or military air base, the CD may specify a path other than the far edge of the runway (e.g., center line) over which the maneuver shall be flown.

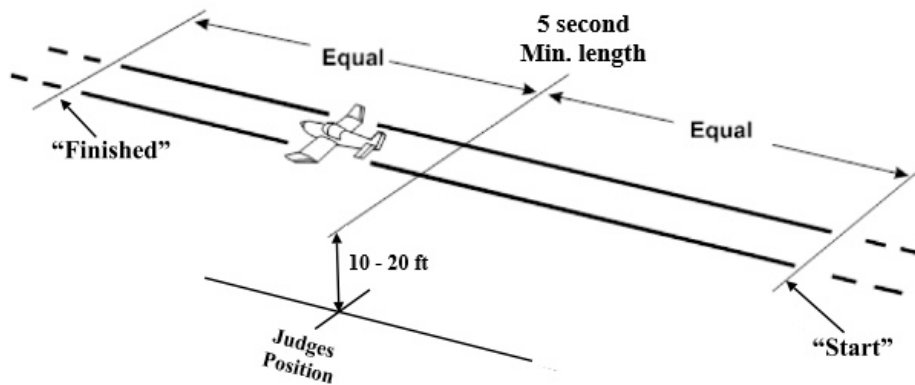

Errors:

- Straight and level flight at a constant altitude is not maintained during the minimum time required for the maneuver.
- Note: Wing bank angle for crosswind correction should not be downgraded. Note: slower types of light aircraft should not be downgraded for slight corrections in gusty wind conditions.
- Altitude is not between 10 and 20 feet.
- The maneuver is offset to the right or left of the judges.

1.2.4. Landing

The landing maneuver begins either when the model commences to flare at the end of a traffic pattern or, if no traffic pattern is performed, when the model is at altitude of 10 feet. There shall be no requirement to touch down in a marked circle, but for maximum points, the model should land approximately opposite the judges.

An aircraft with conventional gear (i.e., with tail wheel) may make a three-point landing or may touch the main wheels first and gently lower the tail wheel as the speed decreases. An aircraft with a tricycle gear should land on the main gear first and gently lower the nose wheel during the roll out. Due to the

non-scale shortness of many landing strips used for contests; it is not always possible for the model to come to a complete stop before it runs out of prepared strip. In all cases, the landing maneuver is complete before the end of the prepared surface. Nose-overs caused by entry into unprepared ground are to be disregarded; quality and control of the landing forming the judging criteria. For this waiver to be effected, the model must make initial contact in the first half of the prepared strip.

The contestant or his helper may call emergency landing when a true emergency occurs during flight. A score will be awarded on the survivability of the aircraft and pilot. A perfect emergency landing can earn a score of ten (10). If the model lands on its back, zero (0) points will be awarded.

Errors:

- Model does not flare or does not flare smoothly (gallops in pitch axis).
- Model bounces at touchdown.
- Model noticeably drops a wing during landing.
- Model touches a wingtip on the runway.
- Tricycle gear model does not touch its main wheels first.
- Model runs erratically after touchdown.
- Model collapses a gear leg on landing.
- Note: If a model runs uncontrollably over the foul line after the touchdown a zero (0) landing score should be given.

1.2.5. Realism in Flight

The realism score shall be awarded in proportion to how well the model simulates the complete flight, stability, takeoff, landing, and taxiing characteristics of the prototype aircraft. The model should

also be judged for its realistic attitude in flight, smoothness of control in yaw, pitch and roll axes, and for use of throttle in aerobatic maneuvers. The model should be flown at speeds that best simulate prototypical maneuvers and overall flight. The model should not be flown excessively fast where it may result in unrealistic high bank angle attitudes and high g loads for typical turns, or excessively slow that results in unrealistic flat or shallow angle turns. The model should not show signs of instability that may be characterized by an erratic flight path. Any model of an aircraft with retractable gear that executes the complete flight presentation with its wheels down shall be downgraded for realism. It is the competitor's option to choose any flight maneuver as long as the prototype aircraft was capable of performing those maneuvers. Full flight performance capabilities need not be performed. No downgrade will be given for choice of maneuvers.

Errors:

- Model does not fly in a realistic manner.
- Attitude in flight is unrealistic.
- Model does not fly smoothly.
- Engine(s) not throttled back in maneuvers that would normally require less than full power.
- Models of aircraft that featured retractable landing gear are flown with their wheels down.

1.3. Description of Optional Maneuvers

Following is a list of commonly seen flight maneuvers which, together with the itemized Scale Operations in section 4.1, should be given first consideration for the selection of the options in the flight path demonstration. A contestant is not, however, limited to the maneuvers in this list and may select any maneuver of his own choosing. A contestant may also deviate from the descriptions of the maneuvers in the following list if the prototype aircraft performed the maneuver in a different manner. In either of these cases, the contestant should be prepared, if asked, to supply appropriate documentation to the Contest Director or the CD's designee that shows how the full-scale aircraft performed the maneuver. Additional fly-past maneuvers, such as a "fast fly-past" or "slow fly-past," are discouraged because of their similarity to the mandatory fly-past (4.2.4) unless the speed, either very fast or very slow, was a

remarkable feature of the prototype aircraft and the contestant wishes to demonstrate that it is also a feature of the model.

1.3.1. Taxi

The model shall taxi in accordance with the sketch below to the starting point for the takeoff.

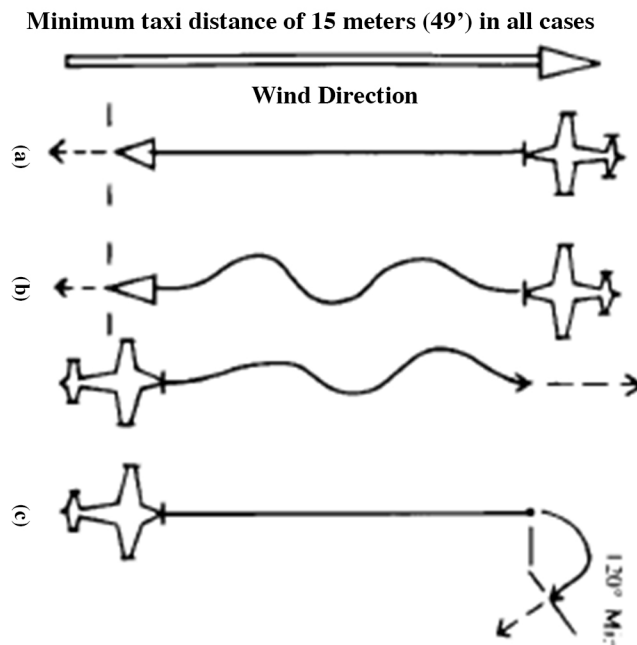

a. Models with two-wheel landing gear and tail skid or unsteerable tail wheel, or other gear configurations not allowing steering will taxi forward into the wind a distance of at least 50 feet, slow down to a near stop or stop, and then become airborne in a realistic manner.

b. Models with two-wheel landing gear and steerable tail wheel will taxi forward into the wind, or downwind if the contestant prefers, a distance of at least 50 feet, using "S" turn visibility taxiing procedure, slow down to a near stop or stop (depending on whether or not the prototype was equipped with brakes) and then become airborne in a realistic manner.

c. Models with steerable tricycle landing gear will taxi downwind at least 50 feet, stop, turn at least 120 degrees into the wind and become airborne in a realistic manner. After landing, the model shall perform a taxi maneuver as follows:

d. After landing, model shall perform a taxi maneuver as follows:

1. After landing, model will slow to a near stop or stop and then taxi forward in a realistic manner for a distance of at least 50 feet (see 4.3.1 (a)).
2. After landing, model shall return in a realistic manner to the starting area and stop (see 4.3.1 (b and c)).

Errors:

- Model does not stand still unassisted before commencing to taxi.
- Electric propeller stops anytime during taxi.
- Model does not follow the prescribed course.
- Model does not halt before taking off if prototype had brakes.
- Model taxis too fast. Model does not taxi in the manner of the prototype

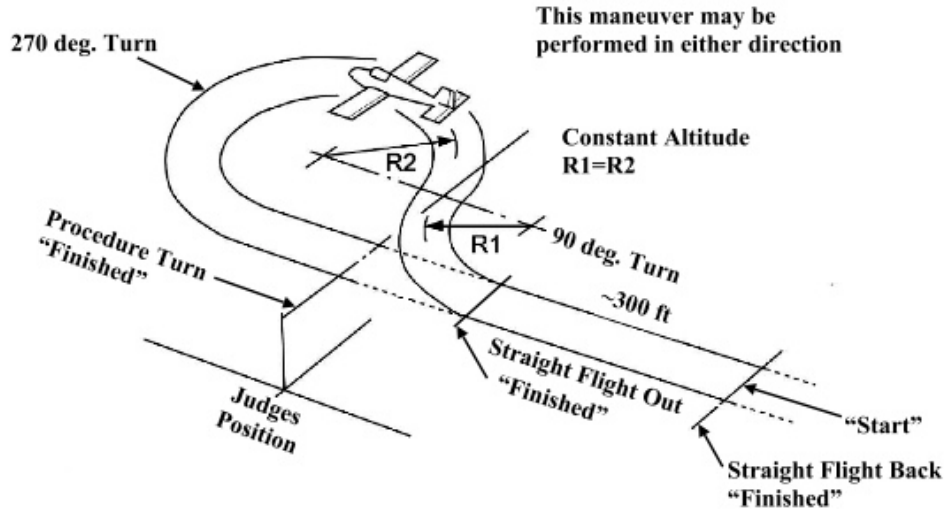

1.3.2. Procedure Turn (see diagram above)

After the straight flight, the model must turn exactly 90 degrees to the left or right, whichever will take the plane away from the spectator line (direction to be specified by the CD), then exactly 270 degrees to the right (or left) and cross over the point where the first turn commenced. All turns and completion at same altitude as entry.

Errors:

- Left turn not 90 degrees.
- Right turn not 270 degrees.
- Changes in altitude during turns.
- Turns not smooth and circular.
- Does not head back over exact outgoing path.

Note: If a contestant wishes to perform this maneuver without preceding it with a Straight Flight Out, it should commence as the model, heading on a line parallel to the runway, begins the 90 degrees turn at a point immediately opposite the judges or over the center of the landing circle (if used).

1.3.3. Inside Loop

From straight flight, the model pulls up into a smooth round loop and resumes straight and level flight on the same heading and altitude as the entry. The throttle should be cut back at the top of the loop and opened when normal flight is resumed. The aircraft has to stay in one plane and the wings remain perpendicular to the flight path. A light aircraft type would be expected to execute a shallow dive at full throttle in order to pick up speed before commencing the loop. Lower powered aircraft may not be capable of round loops. Competitor should alert judges to egg shaped loop.

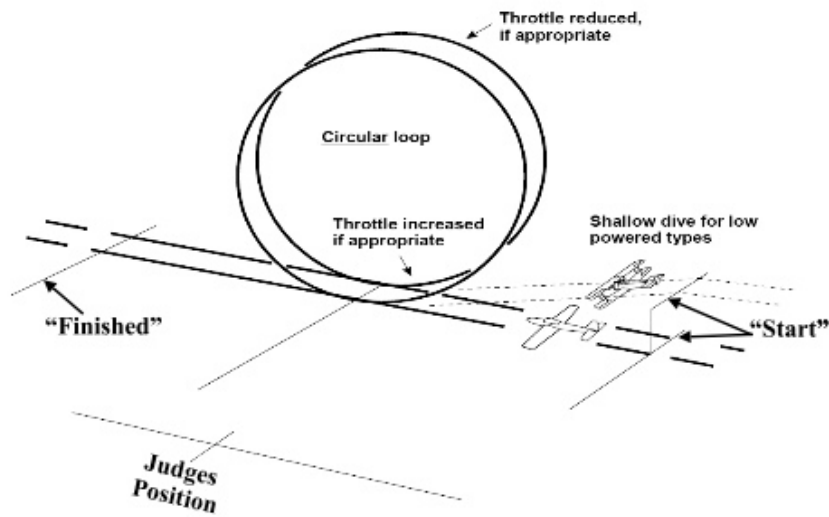

Errors:

- Wings are not level throughout the maneuver.
- Loop is not round or is executed endwise.
- Throttle is not cut back at the top of the loop and opened when normal flight is resumed.
- Model of light aircraft type does not execute shallow dive to pick up speed before commencing the loop.
- Model does not remain in one plane or wings do not stay perpendicular to flight path.

1.3.4. Outside Loop

Starting in level flight, the model noses down to perform a smooth round outside loop which is completed when the model regains its starting altitude and exits in level flight on the same heading as the entry. The throttle should be closed at the beginning of the maneuver and should be opened after completion of the first half of the loop when the model is inverted and is at a point closest to the ground.

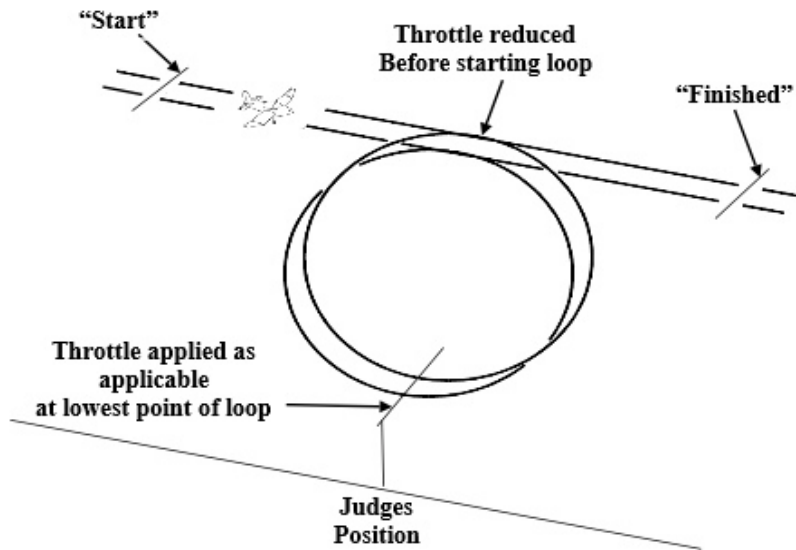

Errors:

- Maneuver does not begin and end in level flight.
- Exit altitude is not the same as entry altitude.
- Model does not begin and end on the same heading.
- Loop is not round.
- Wings do not remain level during maneuver.
- Throttle not closed during first half of maneuver.

1.3.5. Immelmann Turn

From a straight and level flight, the model performs the first half of a loop and when inverted performs a half roll and resumes straight and level flight on the opposite heading. Light aircraft types would be expected to commence the maneuver by executing a shallow dive at full throttle in order to pick up the necessary speed.

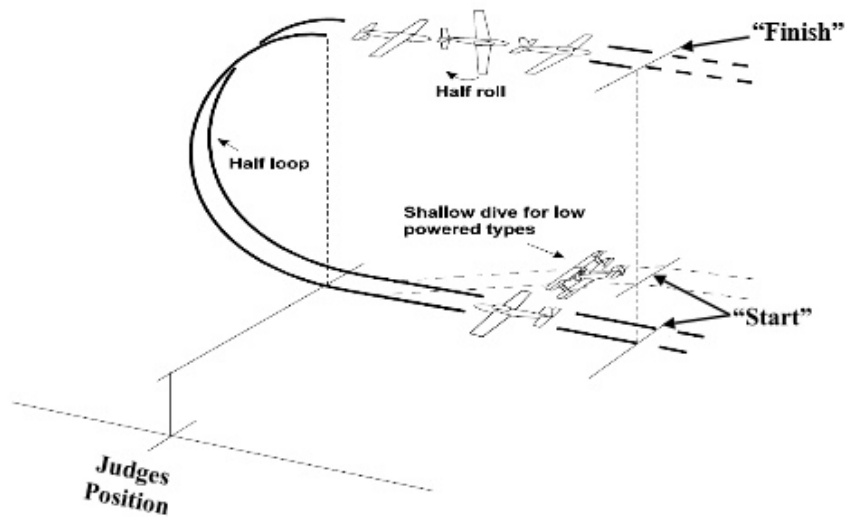

Errors:

- Wings are not level during half loop.
- Model does not resume straight and level flight on the correct heading.
- Model does not remain in one plane or wings do not stay perpendicular to flight path. Both $\frac{1}{4}$ portions of loop are not the same size.
- $\frac{1}{2}$ Loop not completed before roll.
- Inverted line after $\frac{1}{2}$ loop before roll.

1.3.6. Stall/Hammerhead Turn

The model does not actually stall during this maneuver. Start and Finish are aligned with the judges, which should give proper viewing placement for the judges. The model starts in level flight, performs a $\frac{1}{4}$ loop to vertical, the throttle is closed once the vertical line is established. When the airspeed bleeds off, but before stall (model stops on vertical climb) the model yaws through 180 degrees, then dives and finally recovers straight and level flight on a heading in the opposite direction to the entry at the same altitude. The contestant should specify whether the turn will be to the left or right.

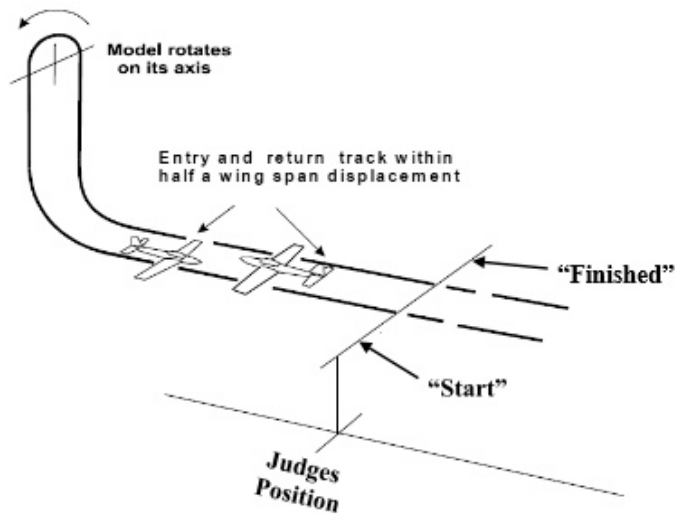

Errors:

- Start and Finish not aligned with judges.
- Horizontal entry and exit lines not parallel with flight line.
- Not enough height gain.
- Model does not stop vertical climb.
- Model full stalls.
- Model does not assume the correct attitude.
- Throttle is not closed. Model turns in wrong direction.
- Horizontal entry and exit lines not at same altitude.
- Horizontal entry and exit lines not within $\frac{1}{2}$ wingspan.

1.3.7. -Wingover

This maneuver will vary depending on the performance level of the aircraft. The model approaches straight and level, parallel to the flight line. The maneuver starts when crossing the judge's position. The model then pulls up into a smooth climbing turn, using rudder, away from the judges. The bank angle at the peak of the turn (90 deg. to the entry track) should be between 45 and 60 deg. for a non-aerobatic

aircraft. An aerobatic aircraft should be at 60 to 90 deg. The height gain should be appropriate for the aircraft modeled. The turn continues while descending to the entry-level altitude. Throttle should be reduced through the descent. The maneuver completes with the exit path at the same altitude and parallel to the entry, finishing opposite the judges position. Split-S (Reversal)

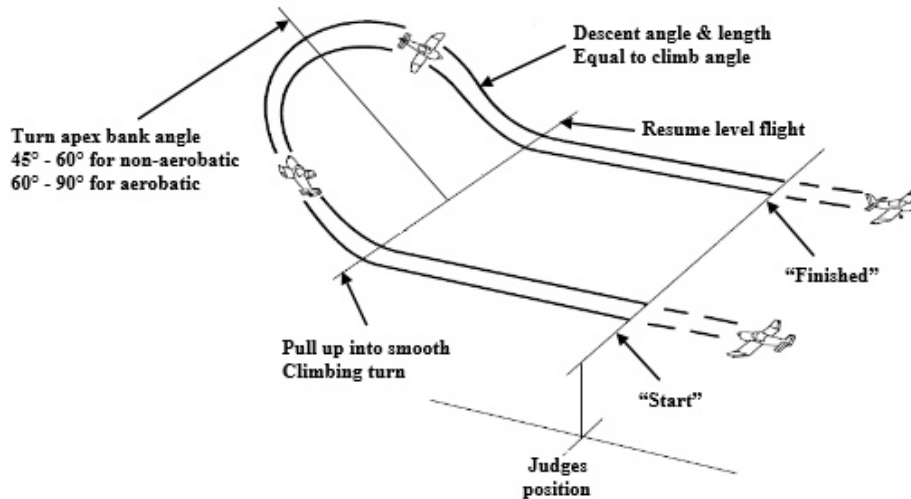

Errors:

- Model not level at start.
- Model rolls left or right during pull up.
- Model tucks under a wing during 180 degrees turn.
- Throttle not closed during dive. Return path not parallel to entry.
- Recovery not at same altitude as entry.
- Model does not fly straight and level to complete the maneuver.

1.3.8. – Split-S (Reversal)

From a straight flight, the model performs a half roll and when inverted, with wings level. When opposite the judges performs the second half of a loop, ending opposite the judges, and resumes straight and level flight on a heading opposite that of the entry. The

throttle should be closed at the start of the second half of a loop and opened when normal flight is resumed.

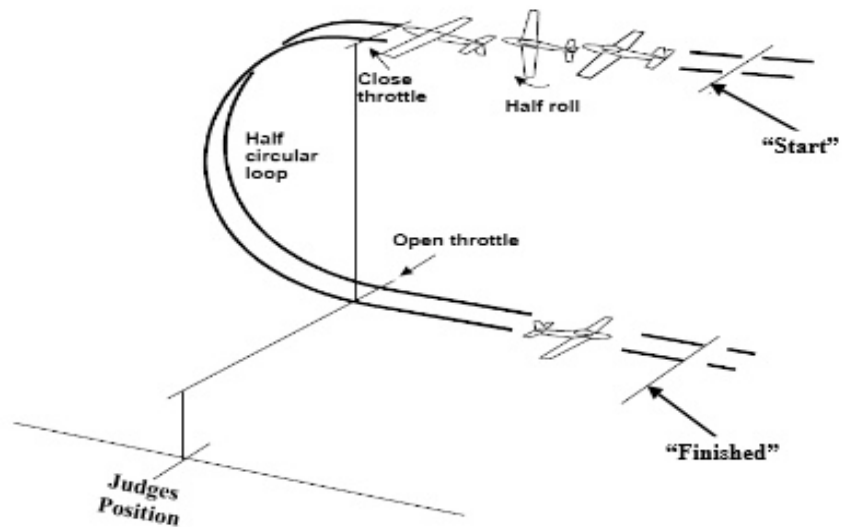

Errors:

- Model changes heading during half roll.
- Wings not level when inverted.
- Wings are not level during half loop.
- Half loop is not round.
- Half loop not centered on judges.
- Half loop too tight or too fast.
- Throttle is not used properly.
- Model does not exit from maneuver on the exact opposite heading to entry.
- Maneuver flight plane is not parallel with the flight line.

1.3.9. Rolls

There are four types of rolls; Aileron, Slow, Barrel, and Snap. The contestant should nominate what type of roll he will perform, i.e., Axial, Slow, Barrel, Snap or Hesitation.

1.3.9.1. – Aileron Axial

The aileron roll is not normally flown in full-scale aerobatic competition. The rudder and elevator remain neutral through the maneuver. From straight and level flight, the model rolls at a constant rate through one (1) complete rotation and resumes straight and level flight on the same heading. The roll is centered so that it is inverted and level when adjacent to the judges. Light aircraft types do not have the power to perform an aileron roll and maintain flight track.

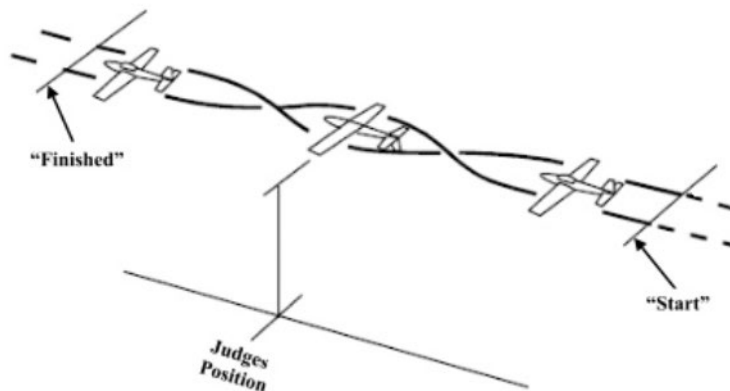

Errors:

- Rate of roll is not constant.
- Exit altitude not the same as at entry.
- Style of roll not typical to prototype.
- Inverted portion of roll not centered on judges' position.
- Entry and exit at different altitude.

- Entry and exit at different speeds.
- Entry and exit tracks and line of roll not parallel with judges' line.
- Does not resume straight and level flight on same track as entry.
- Style of roll not as nominated.
- Inappropriate use of throttle.
- Too far away/too close/too high/too low.

1.3.9.2. – Slow Roll

The slow roll is similar to the axial roll; however, rudder and elevator are used to maintain the track and altitude. Light aircraft types would be expected to execute a shallow dive at full throttle before the maneuver. From straight and level flight, the model rolls at a constant rate through one (1) complete rotation, resumes straight, and level flight on the same heading and altitude as at the start. Generally, military and lightly powered aircraft will pull up about 20° at the start of the roll so the maneuver track will have a slight “hump” in the track. Because the roll rate is slow, the length of the maneuver will be longer than for an axial roll. The center point will still have the wings level in an inverted position adjacent the judges.

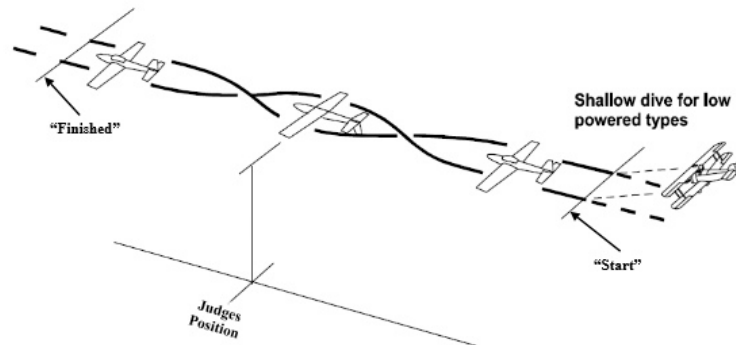

Errors:

- Rate of roll is not constant.
- Exit altitude not the same as at entry.

- Style of roll not typical to prototype.
- Inverted portion of roll not centered on judges' position.
- Entry and exit at different altitude.
- Entry and exit at different speeds.
- Entry and exit tracks and line of roll not parallel with judges' line.
- Does not resume straight and level flight on same track as entry.
- Style of roll not as nominated.
- Inappropriate use of throttle.
- Too far away/too close/too high/too low.

1.3.9.3. Hesitation Roll

The Hesitation Roll is a variation of the Slow Roll including momentary stops at various angles of bank. The roll usually has up to eight hesitation points. A 2-point roll has a hesitation at the inverted position. A 3-point roll hesitates at 120° and a 4-point roll hesitates each 90°. In all cases, the inverted portion is placed in front of the judges.

Errors:

- Rate of roll is not constant.
- Exit altitude not the same as at entry.
- Style of roll not typical to prototype.
- Inverted portion of roll not centered on judges' position.
- Entry and exit at different altitude.
- Entry and exit at different speeds.
- Entry and exit tracks and line of roll not parallel with judges' line.

- Does not resume straight and level flight on same track as entry.
- Style of roll not as nominated.
- Inappropriate use of throttle.
- Too far away/too close/too high/too low.

1.3.9.4. -Barrel Roll

Described is the civil aviation barrel roll. The barrel roll is a maneuver where the aircraft makes a complete rotation along both the pitch and roll axis, forming a helical roll around a straight

flightpath. This beautiful maneuver is not normally flown in full-scale aerobatic competition. To execute, the aircraft starts in straight and level flight the plane starts a brief climb. As the nose passes through the horizon aileron is introduced. As the aircraft rolls, it continues to pitch up. When the airplane has rolled 90° with the wings vertical the nose will be 45° from the entry path. As the aircraft continues to roll inverted, the wings will be level and the nose is 90° off the original flightpath. While the roll continues, when the wings are again vertical, the nose will come back to 45° from the entry flightpath. The aircraft should roll to level flight and be on the same flightpath and altitude as when the maneuver started.

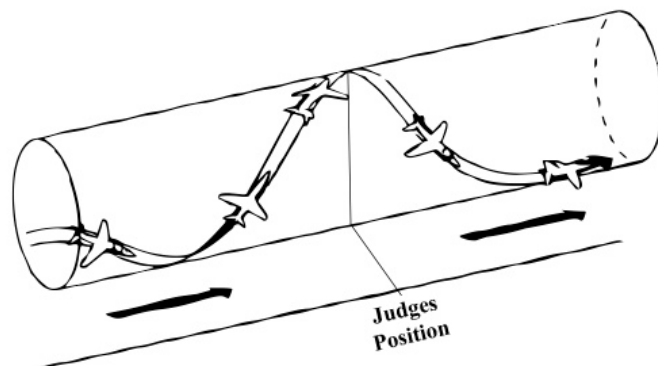

Errors:

- Rate of roll is not constant.
- Exit altitude not the same as at entry.
- Style of roll not typical to prototype.
- Inverted portion of roll not centered on judges' position.
- Entry and exit at different altitude.
- Entry and exit at different speeds.
- Entry and exit tracks not parallel with judges' line.
- Does not resume straight and level flight on same track as entry.
- Style of roll not as nominated.
- Inappropriate use of throttle.
- Too far away/too close/too high/too low.

1.3.9.5. – Snap Roll – Inside

A snap roll is normally flown on a straight line. The model begins in level flight and as the nose is pulled up to the point where the wing will stall, rudder is applied to roll the model in the desired direction. The nose of the model should break the line of flight in a direction towards the pilot's cockpit, indicating that a stall has occurred. While most models will roll faster in a snap roll than in an aileron-induced roll, roll rate should not be a factor in judging. The roll should stop precisely when the model is again upright, and the maneuver should be completed in straight and level flight. Snap rolls may be performed vertically or on a 45-degree climbing or diving flight path, but such maneuvers should always begin and end in straight and level flight.

Errors:

- Model does not begin and end in straight and level flight.
- Wing does not stall during roll.
- Roll is not terminated precisely after 360-degree rotation.
- Model does not exit from the maneuver on the same heading as the entry.

1.3.9.6. Snap Roll - Outside

This maneuver should be performed in a similar manner to the inside snap roll except that, as the break occurs, the nose of the model moves away from the direction of the pilot's cockpit indicating that a stall was induced by the application of down elevator control.

Errors:

- Model does not begin and end in straight and level flight.
- Wing does not stall during roll.
- Roll is not terminated precisely after 360-degree rotation.
- Model does not exit from the maneuver on the same heading as the entry.

1.3.9.7. One (1) Lap Pylon or Speed Run Demonstration

Models performing this maneuver must be model of pylon racers or long-distance race aircraft. Models of aircraft which raced over a closed course (pylon racers) shall perform one (1) lap of a simulated equilateral triangular racecourse. One (1) leg of this shall be parallel to the runway. Models of long-distance race aircraft may make a single high-speed pass parallel to the runway (at a distance consistent with safety considerations).

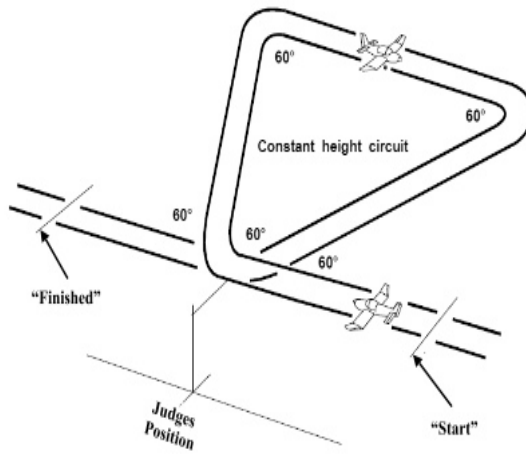

Errors:

- Apex of triangular course not centered on judges.
- Model does not fly straight and level during the designated straight legs of the maneuver.
- Model does not make a pass parallel to the runway.
- Models of pylon racers do not perform turns in the manner of race aircraft (model yaws noticeably when banked, model gains or loses excessive altitude in turns).
- Legs of course not straight.
- Legs of course too short or too long. Triangle angles not 60°.
- Entry / Exit paths not parallel to flight line.
- No compensation for wind.

1.3.9.8. Spin

The number of turns to be performed shall be noted on the judges' score sheets. The contestant may choose any whole number. The entry shall be from straight and level flight parallel to the runway. Power shall be reduced, and the model should remain on heading in a slightly nose

high attitude until it stalls and commences to spin. The model should auto rotate through the prescribed number of turns and recover on the same heading at a lower altitude. The rate at which the model rotates in the spin will depend on its size and type, but judges should be alert to observe models that are performing a spiral dive rather than a true spin.

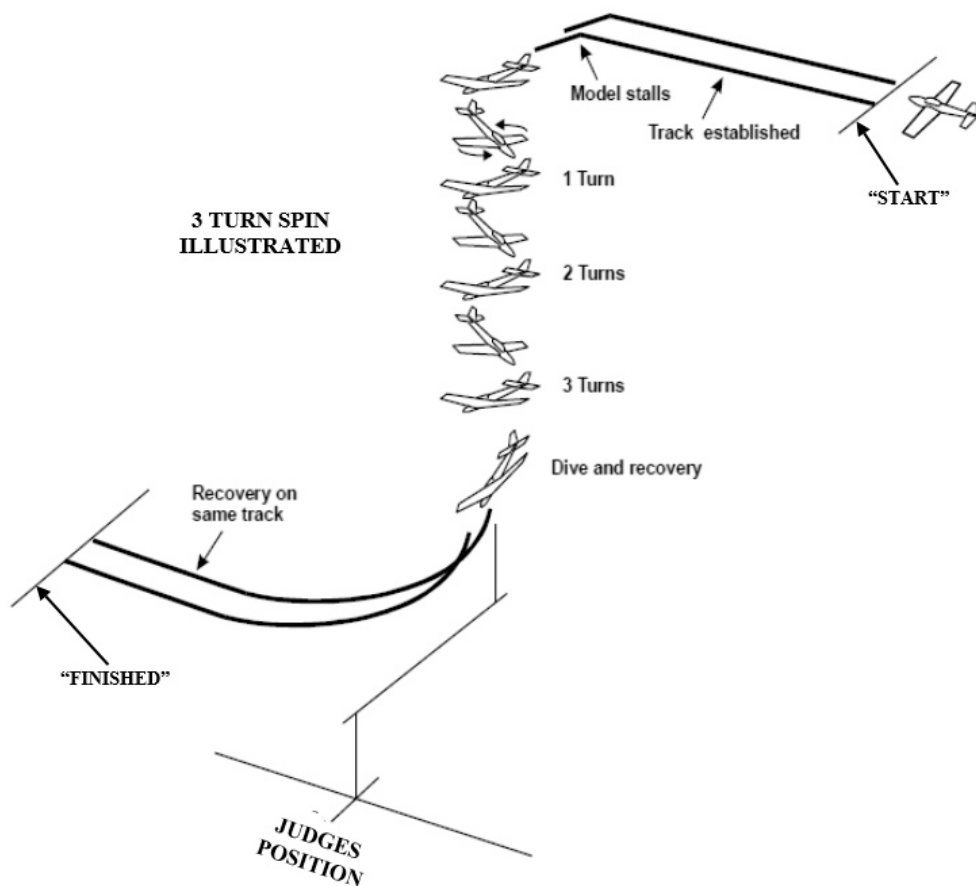

Errors:

- Entry not from level flight parallel to runway.
- Does not perform the prescribed number of turns.
- If the number of turns performed is greater or less than the prescribed number by more than one (1) complete turn, a zero (0) score should be given.
- Does not recover on same heading as entry.

- Wings not level during recovery.
- A spiral dive rather than a true spin shall be scored zero (0).

1.3.10. Cuban Eight

The model starts in straight and level flight, parallel to the flight line. After passing the judges the model pulls up into an inside loop and after completing 5/8 of the loop, heads inverted downwards at 45 degrees, does a half roll followed by 5/8 inside loop to the inverted downwards 45 degrees heading, does another half roll and pulls out into straight flight at the same altitude as then entry and on the same heading.

A light powered aircraft would be expected to execute a shallow dive at full throttle in order to pick up speed before commencing the maneuver. Throttle should be closed at the top of each loop and reopened during each descent.

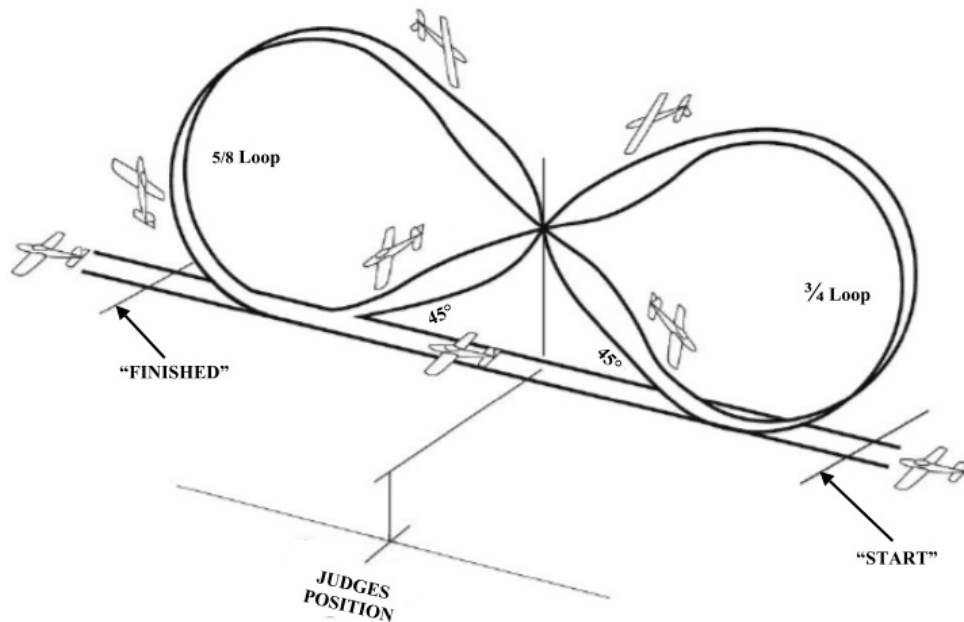

Errors:

- Maneuver not performed in a constant vertical plane or is executed endwise.
- Loops are of unequal diameter.
- Half rolls are not executed at judge's center.
- Down lines are not equal lengths.
- Improper use of throttle during maneuver.
- Model does not exit from the maneuver at the same height as entry.
- Entire maneuver not centered on judges.

4.3.15. $\frac{1}{2}$ Cuban Eight

This maneuver is a shortened version of the Cuban Eight. The model starts in straight and level flight, parallel to the flight line.

After passing the judges the model pulls up into an inside loop. After performing $\frac{5}{8}$ of the loop, the inverted model establishes a downward 45 °line. At judges center a half roll is performed to upright. The descent line continues and the model, recovers at the same altitude as entry on a reverse track from entry. A light powered aircraft would be expected to execute a shallow dive at full throttle in order to pick up speed before commencing the maneuver. Throttle should be closed at the top of each loop and reopened during each descent.

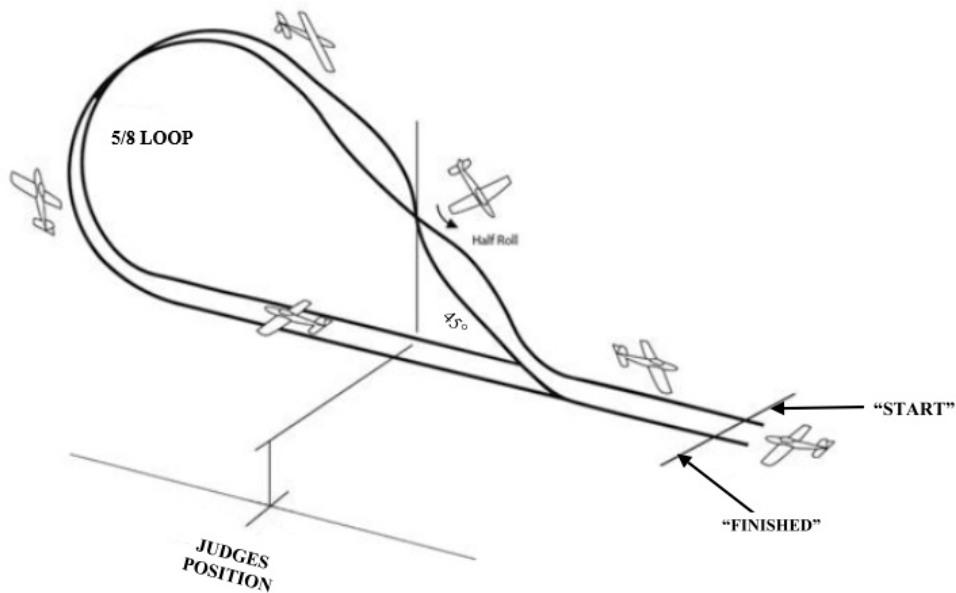

Errors:

- Maneuver not performed in a constant vertical plane.
- Loop is not round.
- Half roll not executed at judge's center.
- Down lines are not equal lengths.
- Model does not exit from the maneuver at the same height as entry.
- Improper use of throttle during maneuver.
- Entire maneuver not centered on judges.

1.3.11. Reverse Cuban Eight

The maneuver starts in straight, level flight parallel to the flight line. Before reaching judges center the model enters a 45° upward line. When reaching judge's center, perform a half roll to inverted and the up line is continued. When reaching the end of the up line, perform a 3/4 inside loop and then establish another 45° upward

line. Perform another half roll to inverted when reaching judges center and continue the up line. Perform a 5/8 inside loop when reaching the end of the up line. Complete the loop at the same altitude and track as the entry in straight and level flight. A light powered aircraft would be expected to execute a shallow dive at full throttle in order to pick up speed before commencing the maneuver. Throttle should be closed at the top of each loop and reopened during each descent.

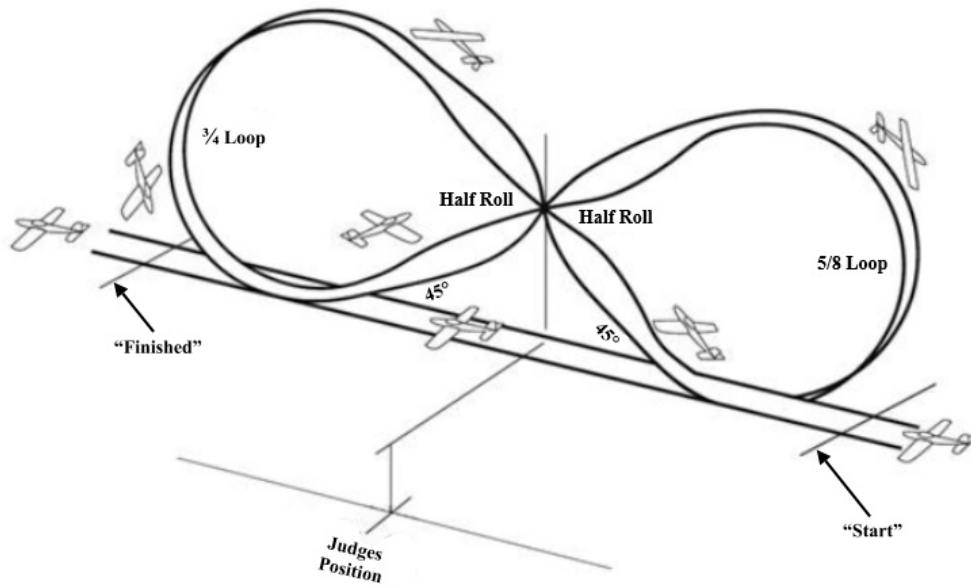

Errors:

- Maneuver not performed in a constant vertical plane or is executed endwise.
- Loops are of unequal diameter.
- Half rolls are not executed at judge's center.
- Down lines are not equal lengths.
- Model does not exit from the maneuver at the same height as entry.
- Improper use of throttle during maneuver.

- Entire maneuver not centered on judges.

1.3.12. $\frac{1}{2}$ Reverse Cuban Eight

This maneuver is a shortened version of the Reverse Cuban Eight. The maneuver starts in straight, level flight parallel to the flight line. Before reaching judges center the model enters a 45° upward line. When reaching judge's center, perform a half roll to inverted and the up line is continued. When reaching the end of the up line, perform a $\frac{5}{8}$ inside loop. Complete the loop at the same altitude and opposite parallel track as the entry in straight and level flight. A light powered aircraft would be expected to execute a shallow dive at full throttle in order to pick up speed before commencing the maneuver. Throttle should be closed at the top of each loop and reopened during each descent.

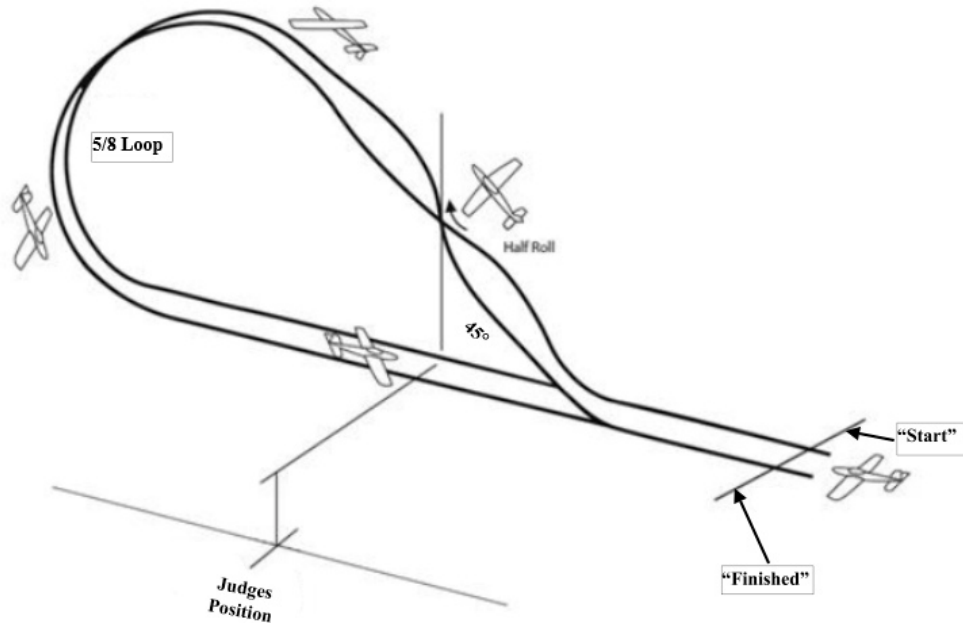

Errors:

- Maneuver not performed in a constant vertical plane.
 - Loop is not round.
 - Half roll not executed at judge's center.
 - Down lines are not equal lengths.
 - Model does not exit from the maneuver at the same height as entry.
 - Improper use of throttle during maneuver.
- Entire maneuver not centered on judges.

1.3.13. Touch-and-Go

This maneuver shall count as two (2) options. After a smooth and gradual descent on a straight-line path into the wind, the model

aircraft then lands and takes off again into the wind without coming to a halt. Crosswind correction is applied as required. The main wheels must roll on the ground for a minimum of 15 ft. Flaps will be used if applicable. Conventional gear models with a tail wheel or skid do not have to touch the tail wheel or skid. Models with a nose gear should touch all gear onto the ground.

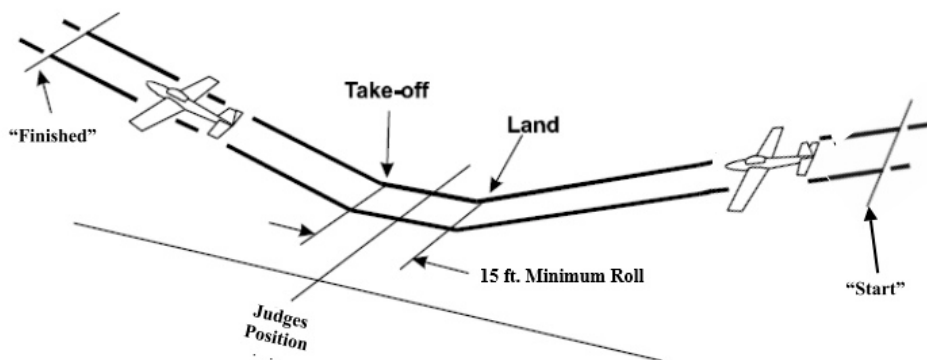

Errors:

- Approach during landing is too steep.
- Violent changes in pitch, yaw or roll during approach or climb out.
- Model bounces on landing.
- Model fails to stay on ground for 15 ft. changes in heading during the takeoff run, versus landing approach.
- Both main wheels must roll on the ground for 15 ft.

1.3.14. – Overshoot

The model makes a landing approach at low throttle to below 10 feet altitude without touching down, followed by a climb out at full throttle to resume level flight. Model should commence by flying a final crosswind leg followed by a turn onto a normal landing approach at low throttle, using flaps if applicable, until it reaches a point over the center of the runway at a point immediately opposite the judges at a height of 10 feet or less. At this point full throttle is applied, and the model climbs straight ahead to resume level flight.

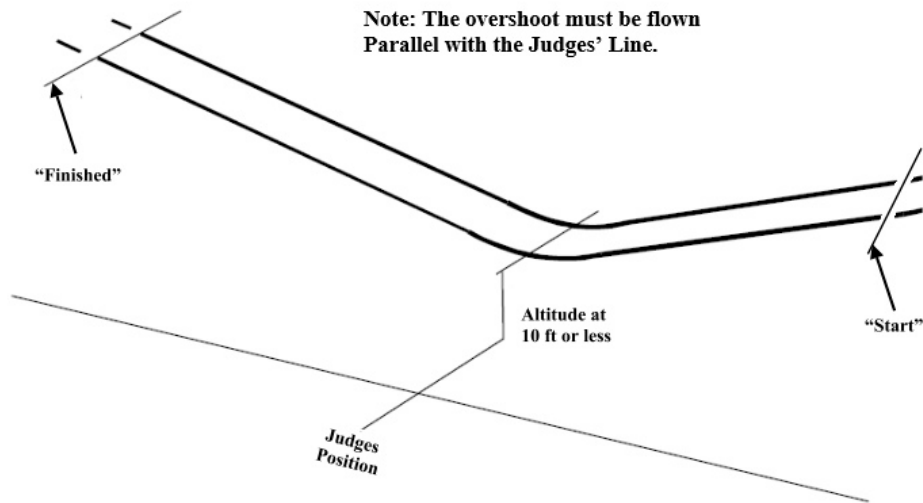

Errors:

- Model does not commence maneuver with the correct landing approach.
- Model must be descending until full throttle is applied, and particular attention should be paid to the timing and altitude when throttle is opened.
- Model does not use flaps (if applicable).
- Model does not climb away smoothly.
- Landing gear is not retracted on climb out (if applicable)

1.3.15. – Slips

There are two types of slips: Forward and Slide. There is also a slipping turn, but this is not generally performed as a competition maneuver. While the two types of slips are similar, in that they both use crossed controls, their uses and results are different. Use a Forward Slip to maintain the ground track while increasing the descent rate without increasing airspeed. The Side Slip results in a sideways track change in a no wind condition. Use it to counteract a crosswind blowing you off the runway centerline or to adjust

misalignment of track. The pilot must specify if the Slip is for alignment or cross wind correction.

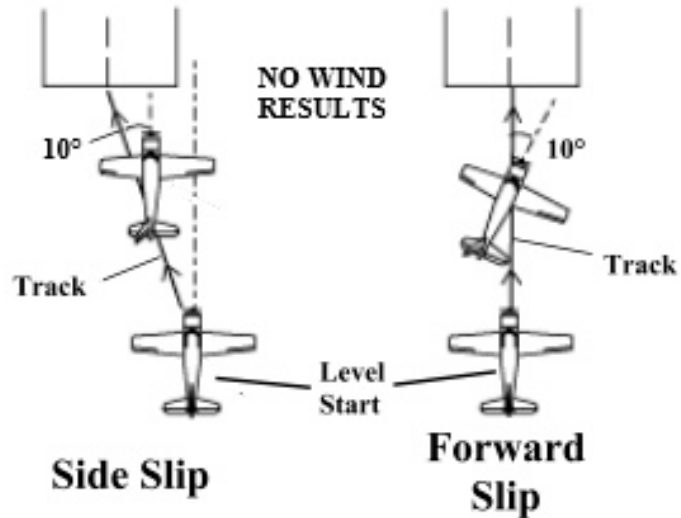

1.3.15.1. Forward Slip

Remember that this maneuver maintains track while the longitudinal aircraft axis is at a minimum 10° angle to the track. Perform the maneuver by lowering a wing while simultaneously applying opposite rudder. The lowered wing should be into whatever crosswind is present. The descent should be steeper than normal but without an increase in airspeed. Maneuver continues to below 10 ft. of altitude, terminating at the judges' position with a transition to normal flight attitude and overshoot with normal climb out.

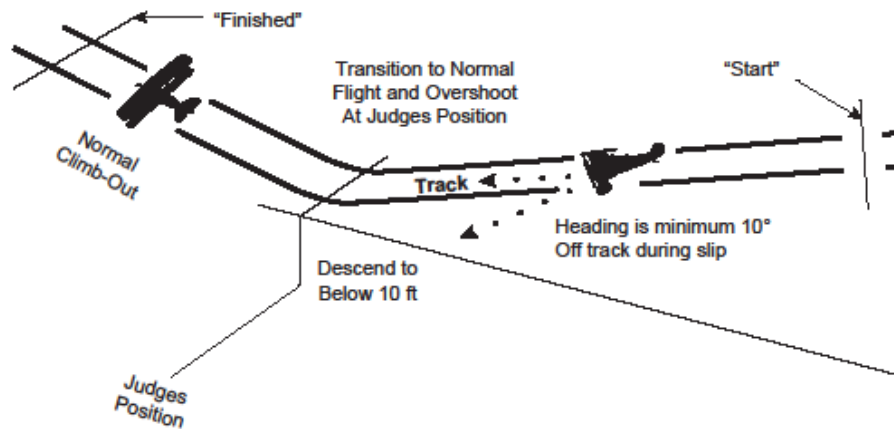

Errors:

- Flight track not parallel to flight line.
- Aircraft heading is not at least 15° angle to track.
- Descent is not steeper than normal.
- Airspeed is too high.
- Slip does not end at Judges' position.
- Model does not transition to normal climb.
- Whole maneuver not centered on judges.

1.3.15.2. Side Slip

This maneuver allows easy correction of misaligned flight track. The heading of the aircraft does not change, but a sideways track results. Perform the maneuver by lowering a wing in the desired track correction while simultaneously applying opposite rudder. The model should visibly move sideways for 5 ft. to 10 ft. Simultaneously remove cross control and resume normal coordinated flight when the aircraft reaches the desired alignment.

The Side Slip maneuver also allows correction for crosswind (side wind) influence. The heading of the aircraft does not change. The track does not change because the side slip counteracts the side push from the wind. The descent might not be steeper than normal. Perform the maneuver by lowering a wing into the wind while simultaneously applying opposite rudder. The wing is lowered enough to compensate for the side push of the wind. The rudder amount is that needed to maintain the heading of the aircraft. The resultant track is a maintained runway centerline. The maneuver continues to below 10 ft. of altitude, terminating at the judges' position with a transition to normal flight attitude and overshoot with normal crosswind climb out.

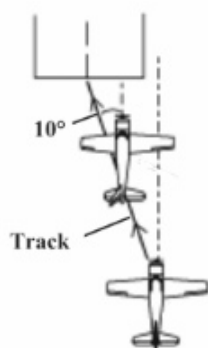

Track Change Side Slip

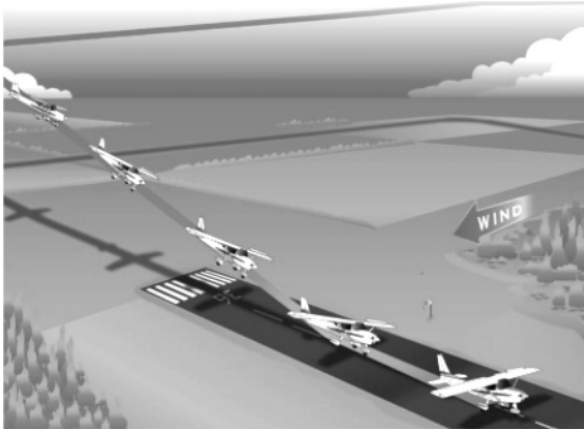

Side Slip for cross wind correction

Errors:

- Pilot does not specify purpose of slip.
- Track does not visibly change for alignment correction slip.
- Track does not maintain parallel to runway for cross wind approach.
- Aircraft is not stable during slip.
- Slip does not end at Judges' position.
- Model does not transition to normal climb for alignment correction or with normal crosswind climb out for cross wind approach.
- Whole maneuver not centered on judges.

1.3.16. Flight in a Triangular Circuit

This maneuver may only be selected for non-aerobatic aircraft. The model approaches upwind (parallel to the flight line) in a straight and level flight to a point above the center of the circle (if used) or opposite the judges, and turns away from the flight line (say left) through 60 degrees and flies straight and level for approximately 300 feet, turns left through 120 degrees and flies a further 300 feet, again turns left through 120 degrees and flies a further 300 feet to a position over the circle center (the starting point) which completes an equilateral triangle. The model then leaves the maneuver through a final left turn through 60 degrees and resumes straight

and level flight on the same heading as the entry. Note that the direction of the turn will be reversed for wind in the opposite direction.

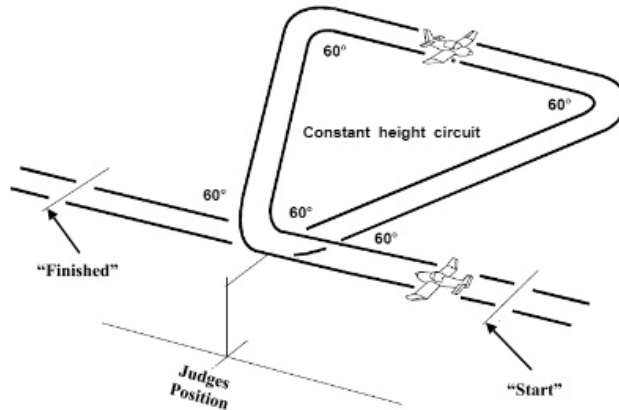

Errors:

- Maneuver is not commenced and terminated at the correct point.
- Model changes altitude during maneuver.
- Legs are noticeably too long or too short.
- Legs are not straight.
- Correction for wind drift is not properly made.
- Rate of turn at corners is not constant.

1.3.17. Flight in a Rectangular Circuit

This maneuver may only be selected for non-aerobatic aircraft. The model approaches upwind in a straight and level flight to a point above the center of the circle (if used) or opposite the judges, and continues at which point it turns away from the flight line (say left) through 90 degrees, flies straight and level, turns left through 90 degrees, turns left through 90 degrees and flies back towards the flight line to end the maneuver over the circle center (the starting point). A further left turn, which must be made to avoid flying over the flight line, is not assessed as a part of the maneuver. Note that the direction of the turns will be reversed for wind in the opposite direction. Also size of the maneuver may vary depending on scale size of the model.

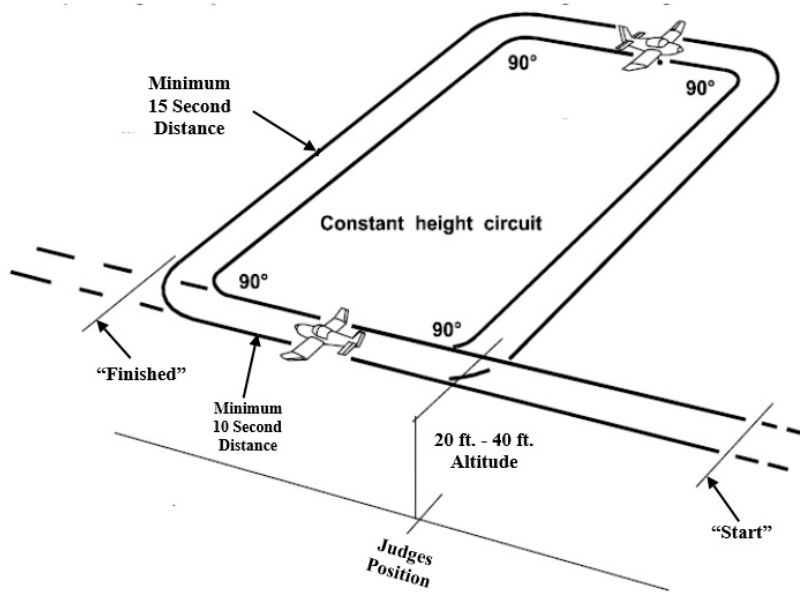

Errors:

- Maneuver is not commenced and terminated at the correct point.
- Model changes altitude during maneuver.
- Legs are noticeably too long or too short.
- Legs are not straight.
- Correction for wind drift is incorrect.
- Rate of turn at corners is not constant.

1.3.18. – *Flight in a Straight Line with One Engine Throttled*

This option is, of course, for multiengine models only. The model approaches into the wind in straight and level flight at a constant altitude with one (1) engine throttled for a minimum distance of 300 feet, after which the throttled engine is opened up and the model resumes normal flight. Crosswind correction may be applied without loss of points, but track must be straight.

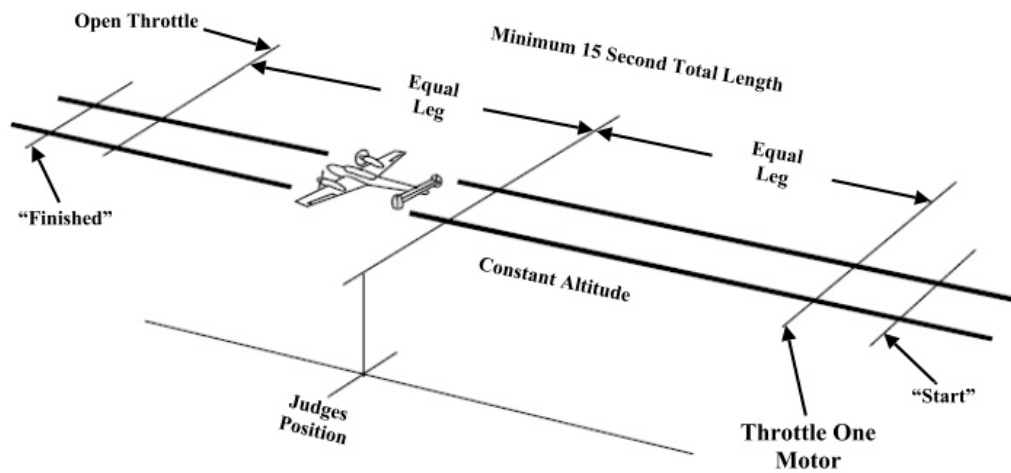

Errors:

- Model does not maintain straight flight.
- Model is unstable.
- Altitude not maintained.
- No wind compensation.
- Engine is not opened up again after demonstration.

1.3.19. -Standard Traffic Pattern Approach to Landing

The rectangular traffic pattern consists of 5 legs; Upwind, Crosswind, Downwind, Base, & Final. The model goes directly into the landing from this maneuver. The model begins on an upwind heading directly over the centerline of the runway. After passing in front of the judges it should continue, straight and level. For approximately 100 – 200 feet before making a 90-degree turn away from the flight line onto the first crosswind leg. Aircraft bank angles should be between 30° and 45° maximum for all turns. A second 90-degree turn begins a downwind leg with the model flying a constant altitude and again passing in front of the judges.

A third 90-degree turn toward the flight line begins the base leg during which the model may begin its descent. A fourth 90-degree turn into the wind, final approach leg, should line the model up with the runway centerline, and straight descending flights should continue to the point of touchdown. The maneuver is considered completed when the model begins to flare prior to landing.

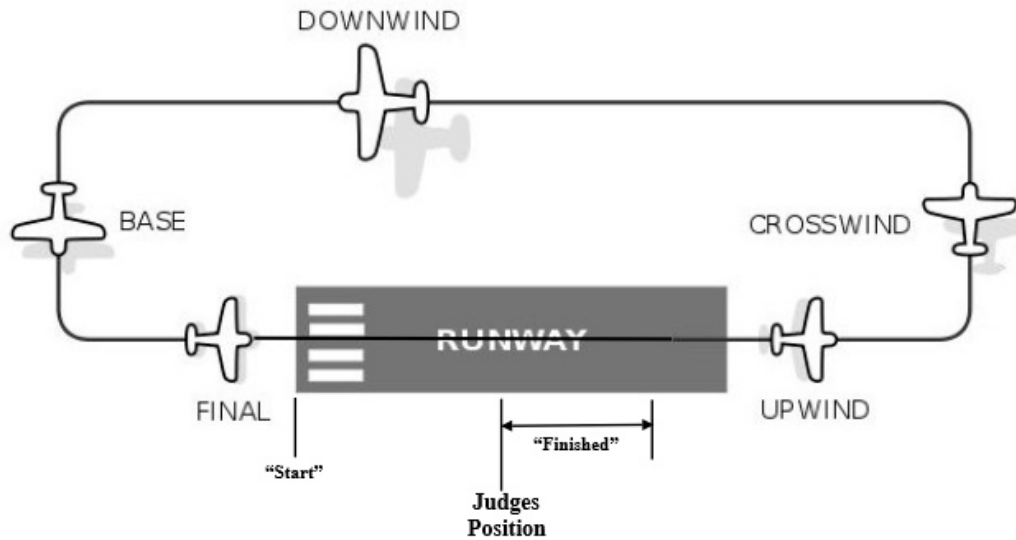

Errors:

- Any change in altitude during the upwind, crosswind and downwind legs.
- Deviation from a straight and level path on any leg.
- Excessive use of the throttle during the final approach.
- Note: Where applicable, wheels should be lowered on the downwind leg and flaps on the base leg.

1.3.20. – Overhead Approach to Landing

While open to all aircraft the overhead approach is generally used by military aircraft as the purpose of the approach is safe, higher speed, efficient recovery of multiple aircraft. Start the approach at the Initial Point on centerline of the runway, flying at a low cruise

setting. Fly at constant altitude to the Break point, where a 180° turn is started. On turn completion, a straight leg is flown for 5 – 10 seconds, where a descending 180° turn commences. At turn completion, fly straight, while descending to landing. Maneuver completes at flair for landing. Crosswind correction is applied as appropriate.

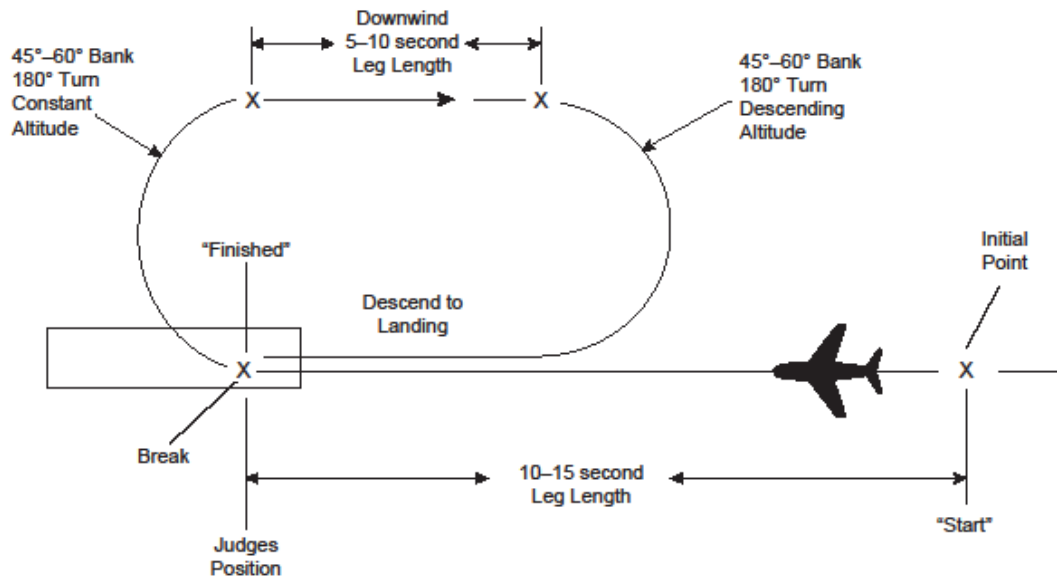

Errors:

- Initial leg not correct length.
- Initial leg not straight or at constant altitude.
- Break turn not at constant altitude.
- Downwind leg not at constant altitude.

- Downwind leg is not straight.
- Turns not round.
- Turns not at constant bank angle.
- Descending leg is not straight.

1.3.21. - Spot Landing

If the main gear of the model makes its first contact with the ground within a 100-foot diameter circle, the judges shall award points equal to those awarded for the landing. All judges must agree on whether or not the model did touch down within the circle.

1.3.22. Slow Speed Inspection Pass

This maneuver includes the described transition periods on a common heading and elevation to enter and exit slow flight. The model shall transition smoothly into and out of a high lift and high drag aerodynamic configuration using the applicable features of the aircraft. As a minimum, this maneuver must include the use of fully deployed flaps as the model is progressively brought to its slow flyby speed. This will be along a straight and level path parallel and over the far edge of the runway from the spectators (or as otherwise specified by the CD), at an elevation of between 20 and 40 feet for a minimum of five (5) seconds. This

slow midpoint period of the maneuver should be opposite the judges. The model's flying speed during the Slow Speed Inspection Pass should be remarkably slower than the mandatory fly-past*, to the extent that the apparent stall speed has been effectively reduced by use of flaps and other applicable features. The model will often require some low-level power to "drag" it through this high drag period.

The model will then slowly transition out of this high lift and high drag profile while speed is again increased. This transition should not include immediate lifting of flaps prior to increasing speed, which could otherwise stall the model. Immediate flap retraction may be a direct indication to the judges that the model was not sufficiently slowed to optimally demonstrate the Slow Speed Inspection Pass. This high drag slow maneuver performed along a near level path requires skill in power management, judgment of

model speed verses stall, and coordination of all applicable scale operations to transition accordingly.

*When electing this maneuver, it must immediately follow the mandatory Fly-Past.

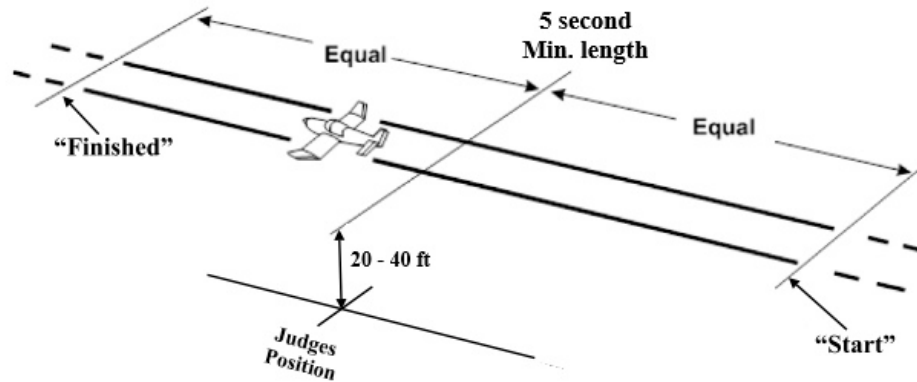

Errors:

- A smooth, straight and level flight at a constant altitude is not provided to transition into, during, and out of the Slow Speed Inspection Pass.
- It is not stable or on the same heading.
- Note: Allowances shall be made for corrections in gusty wind conditions.
- Altitude is not between 20 and 40 feet.
- The maneuver is offset to the left or right of the judges.
- The 5-second slow speed portion is not remarkably slower than the mandatory Fly-Past.
- All applicable high lift or high drag features such as flaps and retracts were not deployed.
- If flaps were not deployed, the maneuver will score a zero.

1.3.23. Chandelle

This maneuver is not an aerobatic maneuver, but a performance maneuver. It is a specialized climbing turn in which the airplane changes direction through 180 degrees and gains as much altitude as possible. It is available to all aircraft. The aircraft flies straight

and level from maneuver start for 2 – 3 seconds for established entry. Start a Climbing turn by simultaneously add available power, smoothly rolling into a 30° Bank and starting to add pitch up. Maintain the bank angle and continue to increase pitch, reaching the maximum pitch at 90°. From 90° thru 180°, maintain the pitch angle while smoothly and slowly decreasing bank angle, reaching wings level at 180° with airspeed just above stall. Maintain level flight at airspeed for 2 – seconds, and then transition to normal flight. The entire turn is a constant rate turn, achieved because of rudder use with the decreasing bank angle.

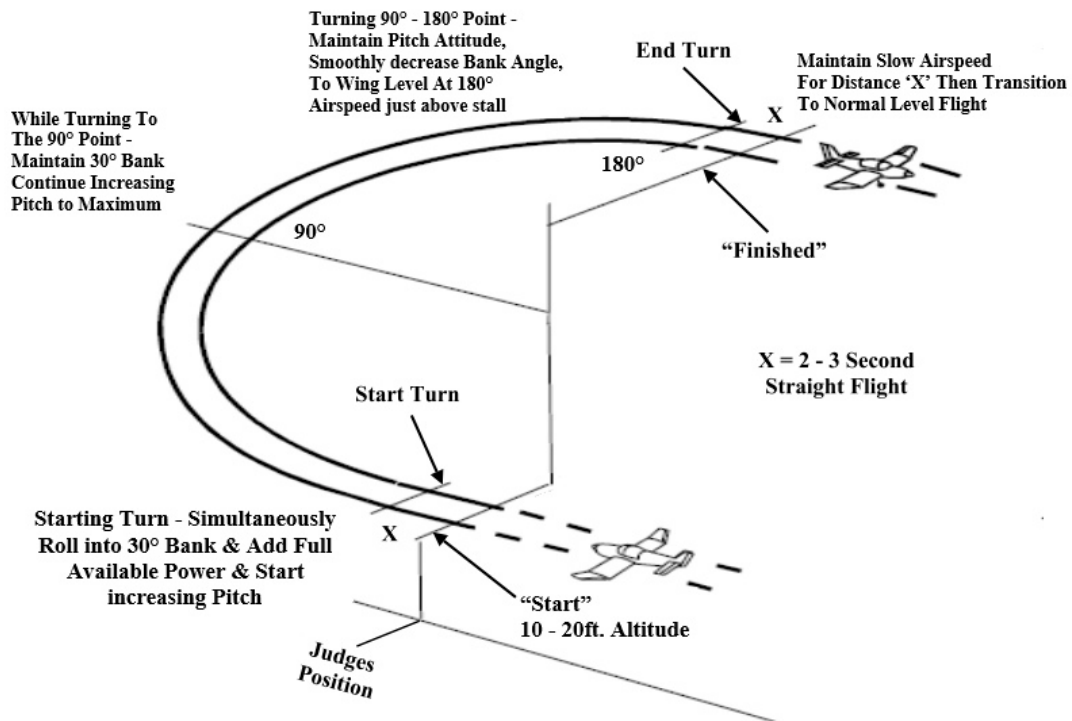

Errors:

- The same turn rate is not maintained.

- The model slips or skids.
- The model does not provide a notable climb rate.
- The model is not near stall speed at maneuver completion.
- The model does not finish with wings level on a heading opposite to that entered.

1.3.24. Any Other Flight Maneuver

A contestant may perform any flight maneuver of his own choice provided that it is within the capabilities of the prototype aircraft. Such a maneuver must be cleared by the Contest Director prior to flight time and, if necessary, a short description of the maneuver may be requested by the CD for use by the flight judges. The contestant should describe the maneuver, as described to the CD, to the judges before the flight round starts to ensure judges understanding.

1.3.25. 360 Degree Descending Circle at a constant low throttle setting

Commencing from straight and level flight, the model aircraft performs a gentle 360-degree descending circle in a direction away from the judges at a constant low throttle setting. The maneuver terminates at a height between 10 and 20 feet resuming straight and level flight on the same path.

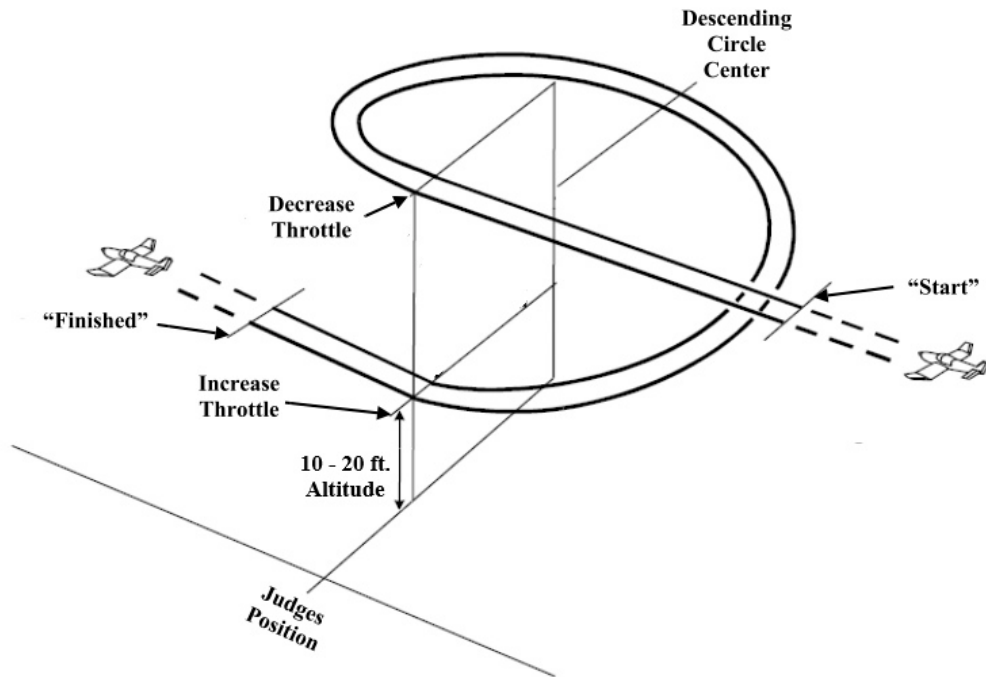

Errors:

- Rate of descent not constant.
- Descent too steep.
- Throttle not constant or low enough.
- Circle misshapen.
- No significant loss of height.
- Descent not to a level of 10 or 20 feet.
- Circle not centered on judges' position
- Entry and exit paths not parallel with judge's line.
- Too far away or too close.

1.3.26. *Lazy Eight*

As with the Chandelle, the Lazy 8 maneuver is not an aerobatic maneuver but a performance maneuver. Therefore, it is available to all aircraft. It gets its' name because the nose of the plane is

following a figure 8 on its side on the horizon, the plan view of the maneuver is not a figure 8. The lazy 8 is a maneuver designed to develop perfect coordination of controls through a wide range of airspeeds and altitudes. It is the only standard flight training maneuver during which at no time do the forces on the controls remain constant. A lazy 8 consists of two 180° turns, in opposite directions, while making a climb and a descent in a symmetrical pattern during each of the turns. At no time throughout the lazy 8 is the airplane flown straight and level; instead, it is rolled directly from one bank to the other with the wings level only at the moment the turn is reversed at the completion of each 180° change in heading. The maneuver starts in straight, level flight parallel with the flight line at 20 – 40ft altitude. Start a gradual climbing turn toward the 45° reference point when reaching the judges position. Control the climbing turn so that the aircraft reaches maximum pitch attitude, approximately 15°, and approximately 15° bank angle at the 45° reference point. The turn rate will naturally attempt to increase as the airspeed decreases, so start with a slow rate of roll so that you do not reach the 45° reference before

maximum pitch is reached. The climbing turn continues to the 90° reference point. At the 90° point, the airspeed is at minimum, maximum altitude has been reached, pitch attitude is level, and bank angle is between 30° & 45° for non-aerobatic aircraft or between 45° & 60° for aerobatic aircraft. The turn continues as a descending turn to the 135° reference point while slowly decreasing bank angle. At the 135° point, the aircraft is at maximum down pitch, approximately 15°, and approximately 15° bank angle with increasing airspeed. The descending turn continues to the 180° reference point. At this point, the aircraft is in level flight, at entry airspeed, at entry altitude, and parallel to the entry flight path. Immediately start the second 180° climbing turn by flying it like the first. The aircraft finishes the maneuver flying in level flight, at entry airspeed, at entry altitude, parallel, and in the same direction as the entry flight path.

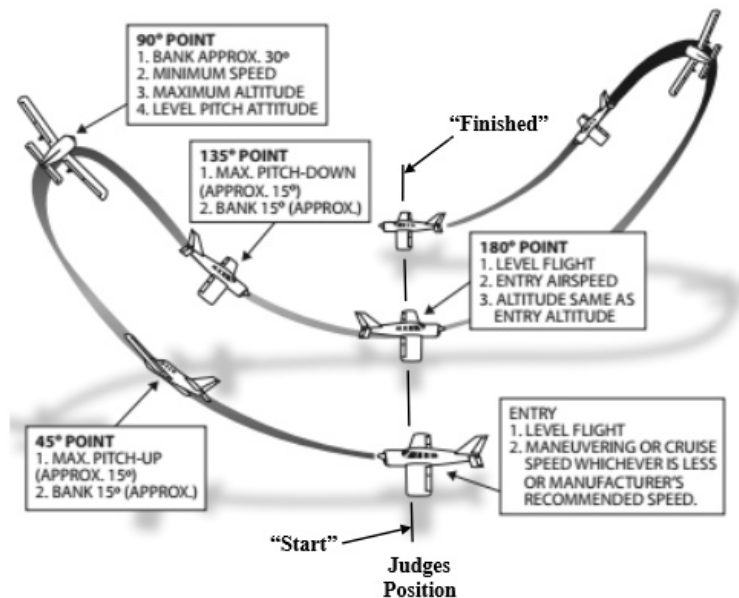

Errors:

- Entry and exit paths not parallel with judges' line.
- Insufficient climb achieved. Insufficient bank achieved.
- Climb and descent angles not equal throughout maneuver.
- Arcs misshapen.
- Maneuver not symmetrical about judges' position.
- Start and finish positions not as indicated.
- Overall size of maneuver not realistic for prototype.
- Model aircraft flight path not smooth and steady.
- Too far away/too close/too high/too low.

1.3.27. Derry Turn

This is a high-speed performance maneuver limited to high performance aircraft. The model approaches at a high speed in straight and level flight on a parallel line with the judges' line. The model then makes a steep bank (in excess of 60 degrees) one-

quarter-circle turn in a direction away from the judges without losing height. When centered in front of the judges, and perpendicular to the entry line, the model makes a half roll inverted in the same rolling direction as the entry, again directly followed by a steep one-quarter-circle turn in the opposite direction, and then flies off straight and level on a line parallel with that of the entry maneuver. The entire maneuver is flown at the same altitude.

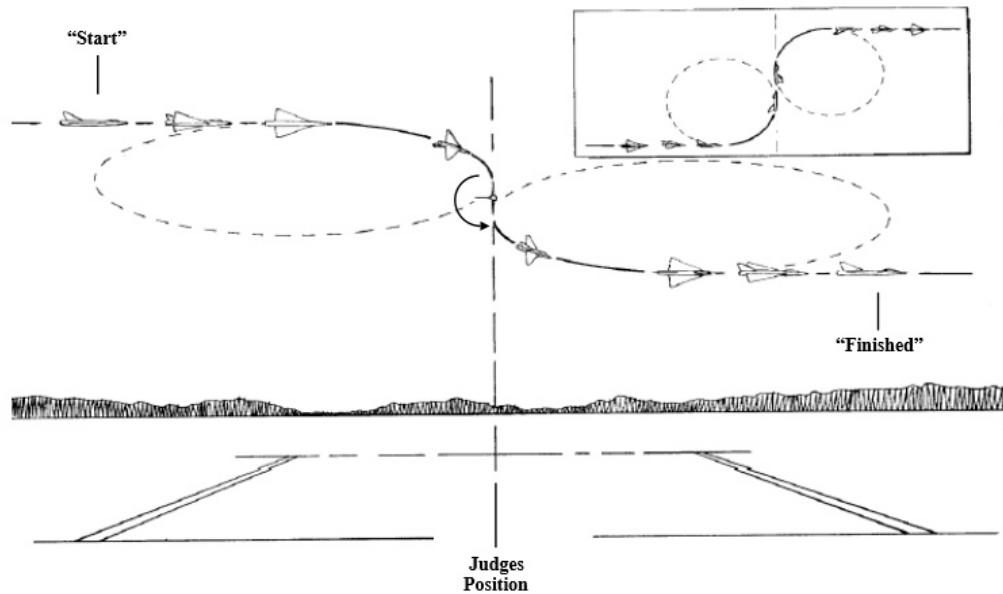

Errors:

- Entry not parallel with judges' line.
- Maneuver not centered in front of judges.
- The rolling maneuver in front of judges not axial on a line directly away from judges.
- The roll in center is not in the same roll direction as the entry to the maneuver. Any hesitation between the end of the first quarter turn, the roll and/or the start of the second turn.
- Exit not parallel with entry.
- Altitude difference during maneuver.
- The maneuver misshapen (as seen as part of a figure eight).

- Maneuver is too low or too high to be easily judged.

RADIO CONTROL SPORT SCALE SOARING

For event 517.

8. Applicability

All pertinent AMA regulations (see sections titled Sanctioned Competition, Records, Selection of Champions, Scale General and General) shall be applicable, except as specified below.

9. Definition

As per RC Sport Scale (events 511, 512, 513), except the event is for scale sailplanes only. Deviation from scale through the inclusion of spoilers, flaps, dive brakes, or other flight control devices (not including thermal-sensing devices which are permitted) which were not used on the prototype will be appropriately downgraded. The maximum weight ready to launch, including ballast, shall not exceed 55 pounds.

10. Builder–Flier

The builder/flier can be, in the case of a highly prefabricated or factory-built glider, the original owner and the one who made it ready to fly, regardless of the scope of the work required to finish the airplane.

11. Proof of Scale

RC Sport Scale section 4 applies.

11.1.

The contestant will include in the declaration a statement as to whether or not the prototype was intended for aerobatics. Flight judges will refer to this in their allowance of up to two (2) or three (3) scale operations. The ability to perform a loop does not necessarily mean that the prototype was designed to perform them. Contestant discretion must apply here, and judges are instructed to accept the contestant's statement.

11.2.

As part of his declaration, the entrant shall specify whether the model was designer-built from factory drawings, built from plans, built from a kit, or bought built covered Almost-Ready-to-Fly (ARF). It will be the responsibility of the pilot to provide verification and describe scope of work and prefab parts supplied.

12. Static Judging

RC Sport Scale section 5 applies with the following additions.

12.1.

A protective skid(s) and/or tow hook may be added after static judging is complete. No downgrade shall be given in the case of a permanently mounted tow hook.

13. Static Scoring

30 points maximum may be earned as follows:

| Category | Points |
|---|---------------|
| Accuracy of Outline (General Impression) | Maximum 10 |
| Finish, Color, and Markings | Maximum 10 |
| Craftsmanship | Maximum 10 |

After static judging is complete, calculate bonus points as follows: multiply score by 2 for designer built, multiply by 1.7 if plans-built, multiply by 1.1 if kit-built, and multiply by .9 if an ARF.

14. Flight

14.1.

Scale judging shall take place before official flying, with static scores to be released at the complete of the entire first round of flying. However, in order for a contestant to receive his/her static score, his/her model must make at least one (1) official flight attempt. If a contestant does not make at least one (1) official fight attempt during the contest, his/her static score shall be zero (0).

14.2.

Launch shall be by winch or aero-tow, high-start. or hand-tow. Organizer-provided winches shall have a line length at 300 meters (984 feet) between launch point and ground-based point. All contestants provided launch equipment can have any length line not exceeding 300 meters between launch point and ground-based point. Weight limit for winch shall be 25 pounds. In the case of Aero tow launch, it shall be the responsibility of the pilot to arrange for a tug if his Sailplane is over 30 pounds or verify that an event-supplied tug is adequate. Two launches per round will be allowed

except for aerotow, if a pilot requires them to complete his flight maneuvers. In the case of two launches, a given maneuver will be judged only once, the first time it is performed.

14.3.

Time limit for each flight is 15 minutes from time of call to completion of landing maneuver.

15. Official Flight

A flight shall be considered official when the aircraft is released from hand tow, winch, or hi-start or other special release launch techniques. If mechanical failure of the hi-start, winch, occurs the flight will be called an “attempt,” with the pilot being able to go to the end of the flight order to make a second attempt at an official flight. A maximum of three (3) attempts per flight will be permitted.

16. RC Flight Plan

The RC Flight Plan shall consist of 10 maneuvers and/or scale operations, three (3) mandatory and seven (7) optional. The mandatory items are:

- a. Three-hundred-sixty-degree thermal turns.
- b. Landing.
- c. Realism in flight.

The mandatory and optional maneuvers may be performed in any sequence but must follow the contestants flight plan presented to the judges.

16.1.

Options may be many maneuvers listed in the Sailplane Section of the Scale Judging Guide or any scale operations (spoilers, flap, etc.) typical of the aircraft modeled. No more than three (3) scale operations may be selected per flight by non-aerobatic sailplanes, or two (2) scale operations for aerobatic designs. Maneuvers and/or scale operations must be listed on the contestant’s flight plan, which will be submitted to the flight judges before flying. The contestant may be asked to prove that his selected maneuver and/or operations have actually been performed by the prototype aircraft type.

16.2.

At the option of the CD, the contestants may be requested to demonstrate on the ground, any scale operation that may be difficult to see in flight (i.e., flaps, spoilers, etc.). The contestant may elect to demonstrate them even if the CD does not require a demonstration. These scale operations

will be demonstrated after the contestant's time has started and need not be demonstrated again in flight during a special declared pass for the judges (though the contestant may elect to do so) but must be used in flight in the same manner as the prototype.

16.3.

The contestant may select different options in succeeding flight rounds, at his choice. Different options may be cleared as "prototypical" by the Contest Director.

17. Flight Scoring

Maximum total flight score is 100 points. Final flight score is arrived at by averaging a contestant's best two (2) flights. Any number of rounds may be flown but CD must indicate before the start of flying what the intended number of rounds will be. Only the two (2) highest flight scores shall be counted, except in cases of ties.

17.1.

All maneuvers and scale operations are to be scored from zero (0) to 10 points, each.

17.2.

No maneuver or scale operation will receive an automatic maximum score. All will be judged in relation to their scale-like qualities.

17.3.

Each flight should be judged by at least two (2) judges, with their scores averaged to give final score for the flight. It is suggested that each maneuver be scored immediately after it is performed. Judges shall score each maneuver individually, and without any consultation between them. There should be enough judges available to establish a rotational procedure which will average out variations in judging.

18. Official Score

The official score shall be the total of static points (30 time multiplier maximum) and the average of the best two (2) flight scores. If only two (2) rounds are flown, then the official score will be the total of static points and the single best flight score.

To break a tie, the best single flight will be added to the static score. If this does not break the tie, add the average of the best three (3) flights to the static score. If this does not break the tie, add the average of the best four (4) flights to the static score.

RADIO CONTROL FLIGHT JUDGING GUIDE—SOARING SECTION

For event 517.

19. Mandatory Maneuvers:

19.1. Three Hundred Sixty Degree Thermal Turns

Beginning from any attitude or altitude, with the entire maneuver visible to all flight judges, the model shall perform two (2) consecutive 360-degree turns, either to the right or to the left. Turn direction shall be pilot's choice. Pilot should attempt to keep both circles concentric. Upon completion of the second turn, model shall resume its original heading.

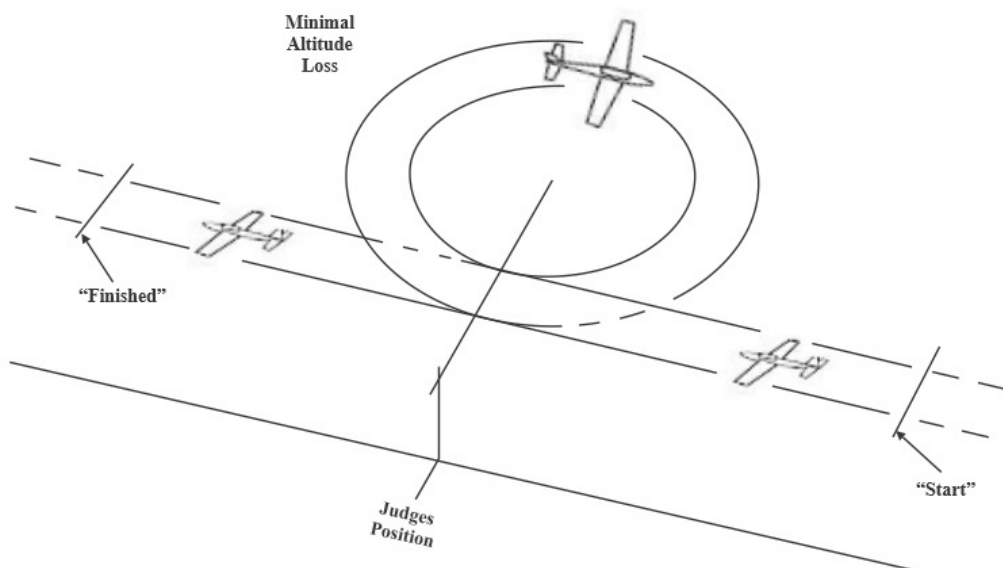

Errors:

- Model does not complete two (2) full 360-degree turns.
- Model flies past the 360-degree point of the second turn.
- Model dives or stalls.
- Model does not keep two (2) circles reasonably concentric. (Note that slight downwind drift is permissible without downgrade, though both circles should be the same size in diameter.)
- Model does not leave the second turn on the same heading at which it entered the first turn.

Slight loss or gain in altitude during the maneuver shall not be cause for downgrade. This is to allow for flight through lift or sink conditions.

19.2. Landing

Final approach shall be a part of the landing task. Maneuver shall begin when the model has completed its turn onto final approach, as announced by the contestant, and shall be considered to be complete when model comes to rest.

Model shall maintain an “on course” attitude toward the landing area until touchdown. Upon touchdown, model shall slide or roll forward to a gradual stop. It is suggested that the actual landing and the final approach be scored on an equal basis by the judges (i.e., a “perfect approach and an upside down landing earning five (5) total points. Approach—five (5) + landing—five (5) total points for landing maneuver.)

Errors:

- Model dives, stalls, or severely changes attitude during final approach.
- Model bounces or stops abruptly on touchdown.
- Model drops a wing too soon after touchdown without appropriate rollout.
- After dropping a wing, model ground loops.
- Model turns upside down.
- Model shedding parts during this maneuver shall be cause for a zero (0) total landing score.

19.3. Realism in Flight

The realism score shall be awarded in proportion to how well the model simulates the complete flight stability, airspeed, landing, and rollout characteristics of the prototype aircraft. The model should also be judged for its attitude in flight and smoothness of control in yaw, pitch, and roll axis. The model should not show signs of instability which may be characterized by an erratic flight path. Any model of an aircraft with retractable gear that executes the complete flight presentation with its wheel(s) down shall be downgraded for realism.

Upon completion of a flight, judges should discuss its realism to attempt to arrive at a unanimously agreed upon score.

Errors:

- Model does not fly at scale-like speed.
- Attitude in flight is unrealistic.
- Model does not fly smoothly.
- Models of aircraft that featured retractable landing gear are flown with their wheel(s) down or do not show wheel(s) extended during landing maneuver.

20. *Optional Flight Maneuvers*

For event 517.

20.1. Climb to Release

From hand tow, winch, or hi-start launch, the model will directly ascend to release altitude and fly smoothly off the towline.

Errors:

- Model weaves from side to side on tow.
- Model's nose dips or rises in a sudden or erratic manner.
- Model "zooms" excessively upon release.
- Winch pulsing causes model to "stutter" on tow.

20.2. Optional Maneuvers

Any maneuver described in the RC Scale Flight Judging Guide or Any Other Flight Maneuver (4.3.27.) may be selected in the contestant's flight plan provided that such maneuvers are within the capabilities of the prototype aircraft. (Examples of optional maneuvers available to aerobatic sailplanes could be Inside Loop, Immelmann Turn, etc., and for non-aerobatic types, Straight Flight Out, Procedure Turn, Straight Flight Back, Flight in a Rectangular Circuit, etc., though neither type shall be restricted to only these specific maneuvers)

20.3. Flight Judging

In all flight judging, the following shall be taken into consideration:

20.3.1.

Downwind drift of non-powered aircraft due to wind conditions during maneuvers.

20.3.2.

Slight gain or loss of altitude in lift or sink conditions during maneuvers.

20.3.3.

Moderate dive of model prior to entering any maneuver which requires a nose-up entry (i.e., Inside Loop, Stall Turn, etc.).

20.3.4.

Appropriate loss of altitude in extended length maneuvers (i.e., Straight Flight Out, Procedure Turn, Straight Flight Back, Flight in a Triangular Circuit, etc.).

20.3.5.

Moderate nose-down attitude to maintain flight speed and penetration ability.

20.3.6.

A sailplane's lack of throttle, engine, or power, in any reference to same during the performance of maneuvers selected from the Scale Judging Guide.

21. Scale Operations

For event 517.

21.1. Dumpable Water Ballast

From any attitude or altitude which will allow all flight judges to have full view of the entire performance, model shall proceed to release water ballast in visually the same manner as its prototype. This option must have the approval of the CD before the start of the contest.

Errors: Water is released at other than the specified time in the contestant's flight plan. Release does not occur. Release is not visible to the judges. Release causes the wetting of other contestants, judges, models, or pre-specified equipment (complaints must be confirmed by the judges).

21.2. Other Optional Demonstration

Any Optional Demonstration described in the RC Scale Flight Judging Guide or Other Optional Demonstration (4.1.9.) may be selected in the contestant's flight plan, provided such operations were within the capabilities of the prototype aircraft.

21.2.1. Judges will make appropriate allowances for conditions applicable to sailplanes, (i.e., Retract and Extend Gear having only a single leg, etc.).

22. SCORE SHEETS:

RCFLIGHT



Fun Scale
Static Score:
#520/#520N/Indoor

0 or 5 (first round only)

RADIO-CONTROL FLIGHT SCORE SHEET

Use for the following AMA Sport Scale Events:

| | | |
|-------------------------------|--------------------------------------|-----------------------|
| #511 RC Sportsman Sport Scale | #520 RC Fun Scale/Division 2 Open | #523 RC Open Scale |
| #512 RC Expert Sport Scale | #520N RC Fun Scale/Division 1 Novice | Indoor RC Fun Scale |
| #515 RC Designer Scale | #522 RC Team Scale | Indoor RC Sport Scale |

Contestant Name: _____ Contestant Number: _____

Event: _____ Flight Number: _____

Aircraft: _____

Aircraft Cruise/Maximum Speed (level flight): _____ Check one: Aerobic Non-Aerobic

Flight Plan

(Note to Contestant: There are 5 mandatory maneuvers - Take off, Figure Eight, Fly Past, Landing and Realism in Flight. Please fill in these, plus your five optional maneuvers and/or scale operations below. All maneuvers will be scored 0-10 points. Maximum possible flight score is 100 points.)

Note to Judges:

Verify that all 5 mandatory are included in the flight plan.

Take off Figure Eight Fly Past Landing Realism in Flight

| Maneuver | Score | Comments |
|----------------------------|-------|----------|
| 1) Take Off | | |
| 2) | | |
| 3) | | |
| 4) | | |
| 5) | | |
| 6) | | |
| 7) | | |
| 8) | | |
| 9) Landing | | |
| 10) Realism in Flight | | |
| Total Flight Score: | _____ | |

Update 02/20

Judge's Initials: _____

RCFLIGHT



RADIO-CONTROL STATIC SCORE SHEET

Use for the following AMA Sport Scale Events:

- | | |
|-------------------------------|-----------------------|
| #511 RC Sportsman Sport Scale | #522 RC Team Scale |
| #512 RC Expert Sport Scale | #523 RC Open Scale |
| #515 RC Designer Scale | Indoor RC Sport Scale |

Contestant Name: _____

Contestant Number: _____

Event: _____

Aircraft: _____

| STATIC SCORING | | |
|--|--------|----------|
| Scoring Guide for Judges: Fair = 0-6 Good = 7-8 Excellent = 9 Outstanding = 10 | | |
| Category | Points | Comments |
| Accuracy of Outline: (Maximum of 40 points) | | |
| Wings: | | |
| Fuselage: | | |
| Tail Group: | | |
| Landing Gear: | | |
| Accuracy of Outline Total: | | |
| Finish, Color & Markings: (Maximum of 30 points) | | |
| Finish: | | |
| Color: | | |
| Markings: | | |
| Finish, Color & Markings Total: | | |
| Craftsmanship: (Maximum of 30 points) | | |
| Total Static Score: | | |

I hereby certify that I am the builder of this aircraft and have followed the **Builder-Of-The-Model** rules as they apply to the class my aircraft is entered in. I certify that this aircraft passes the current weight and thrust limits (in the case of turbines) as spelled out by the current AMA rules. I also certify that this model has been test flown prior to this event.

Signature: _____

Judge's Initials: _____

Update 02/20

RCFLIGHT



Fun Scale
Static Score:
#520/#520N/Indoor

0 or 5 (first round only)

RADIO-CONTROL SOARING FLIGHT SCORE SHEET

Use for the following AMA Sport Scale Events:
#517 RC Sport Scale Soaring

Contestant Name: _____ Contestant Number: _____

Event: _____ Flight Number: _____

Aircraft: _____

Aircraft Cruise/Maximum Speed (level flight): _____ Check one: Aerobic Non-Aerobic

Flight Plan

(Note to Contestant: There are 3 mandatory maneuvers - 360° Thermal Turns, Landing, and Realism in Flight. Please fill in these, plus your five optional maneuvers and/or scale operations below. All maneuvers will be scored 0-10 points. Maximum possible flight score is 100 points.)

Note to Judges:
Verify that all 3 mandatory are included in the flight plan.

360° Thermal Turns Landing Realism in Flight

| Maneuver | Score | Comments |
|-----------------------|-------|----------|
| 1) | | |
| 2) | | |
| 3) | | |
| 4) | | |
| 5) | | |
| 6) | | |
| 7) | | |
| 8) | | |
| 9) Landing | | |
| 10) Realism in Flight | | |

Total Flight Score: _____

Update 02/20

Judge's Initials: _____

RCFLIGHT



RADIO-CONTROL STATIC SCORE SHEET

Use for the following AMA Sport Scale Events:
#517 RC Sport Scale Soaring

Contestant Name: _____ Contestant Number: _____

Event: _____

Aircraft: _____

| STATIC SCORING | | |
|---|--------|----------|
| Category | Points | Comments |
| Accuracy of Outline: (Maximum of 10 points) | | |
| Wings: | | |
| Fuselages: | | |
| Tail Group: | | |
| Accuracy of Outline Total: | | |
| Finish, Color & Markings: (Maximum of 10 points) | | |
| Finish: | | |
| Color: | | |
| Markings: | | |
| Finish, Color & Markings Total: | | |
| Craftsmanship: (Maximum of 10 points) | | |
| Total Static Score: | | |

Bonus Points Multiplier: Designer Built (*2), Plans Built (*1.7), Kit Built (*1.1), ARF (*0.9)

I hereby certify that I am the builder of this aircraft and have followed the **Builder-Of-The-Model** rules as they apply to the class my aircraft is entered in. I certify that this aircraft passes the current weight and thrust limits (in the case of turbines) as spelled out by the current AMA rules. I also certify that this model has been test flown prior to this event.

Signature: _____

Judge's Initials: _____

Update 02/20