

# **dji** FLYCART 30

## Maintenance Manual

v1.0 2024.08

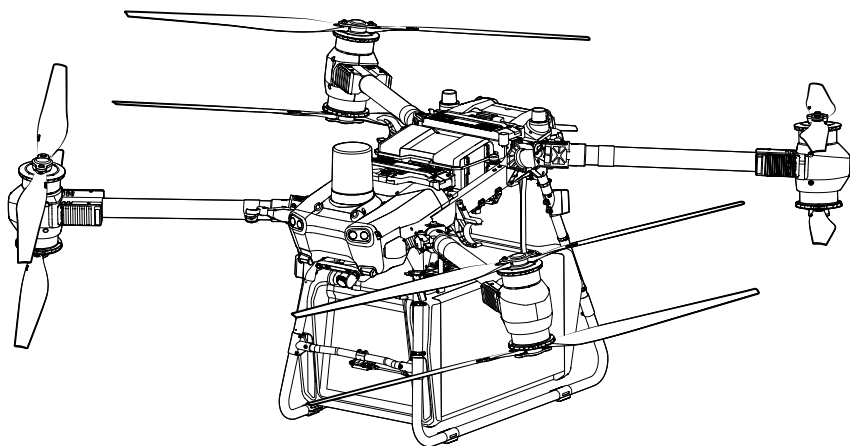



This document is copyrighted by DJI with all rights reserved. Unless otherwise authorized by DJI, you are not eligible to use or allow others to use the document or any part of the document by reproducing, transferring, or selling the document. Users should only refer to this document and the content thereof as instructions to operate DJI products. The document should not be used for other purposes.

### **Searching for Keywords**

Search for keywords such as Battery or Install to find a topic. If you are using Adobe Acrobat Reader to read this document, press Ctrl+F on Windows or Command+F on Mac to begin a search.

### **Navigating to a Topic**

View a complete list of topics in the table of contents. Click on a topic to navigate to that section.

### **Printing this Document**

This document supports high resolution printing.

# Contents

<b>Introduction</b>	4
<b>Disclaimer</b>	4
<b>Fly Safe</b>	5
Flight Condition Requirements	5
Operational Requirements	5
Flight Restricted	5
Storage and Transportation	5
Updating the Firmware	5
Pre-Flight Checklist	6
<b>Inspection and Maintenance</b>	7
Battery Maintenance	15
Checklist for Maintenance	15
Battery Replacement Standard	15
Battery Disposal	16
Battery Usage Notes	16
Firmware Update and System Calibration	16
<b>Health Management System (HMS)</b>	17
<b>DJI Maintenance Program</b>	20
<b>DJI Drone Maintenance Service - DJI FC 30 Winch System Maintenance Guidelines</b>	22
Compatible Aircraft Models	22
Maintenance Rules	22
FAQ	25

## Introduction

This Maintenance Manual offers guidelines to help you in the daily upkeep and maintenance of the product.

This document will focus on the maintenance instructions and the notes, cautions, and warnings during use. Read the User Manual and Maintenance Manual carefully to optimize the user experience. If you have any questions on the maintenance operations, contact DJI Support.

## Disclaimer

Carefully read this entire document and all safe and lawful practices provided by DJI™ before using this product for the first time. Failure to read and follow instructions and warnings may result in serious injury to yourself or others, damage to your DJI product, or damage to other objects in the vicinity. By using this product, you hereby signify that you have read this disclaimer carefully and that you understand and agree to abide by all terms and conditions of this document and all relevant documents of this product. You agree to use this product only for purposes that are proper. You agree that you are solely responsible for your own conduct while using this product, and for any consequences thereof. DJI accepts no liability for damage, injury, or any legal responsibility incurred directly or indirectly from the use of this product.

DJI is a trademark of SZ DJI TECHNOLOGY CO., LTD. (abbreviated as "DJI") and its affiliated companies. Names of products, brands, etc., appearing in this document are trademarks or registered trademarks of their respective owner companies. This product and document are copyrighted by DJI with all rights reserved. No part of this product or document shall be reproduced in any form without the prior written consent or authorization of DJI. This disclaimer is available in various languages. In the event of divergence among different versions, the English version shall prevail. The final interpretation of this document and all related documents of this product belong to DJI. This content is subject to change without prior notice. For up-to-date product information, visit [www.dji.com](http://www.dji.com) and go to the product page for this product.

# Fly Safe

## Flight Condition Requirements

### Operational Requirements

Before use, read the Disclaimer and Safety Guidelines, User Manual, and Maintenance Manual carefully.

### Flight Restricted

1. Connect the aircraft to the internet to update the DJI GEO Zones database regularly. Consult the relevant local government agencies or governing bodies before flight to ensure you comply with all the relevant laws and regulations.
2. If flying in GEO Zones is required, apply for unlocking in advance.  
<https://www.dji.com/flysafe>

## Storage and Transportation

There are safety requirements for the storage and transportation of the Intelligent Flight Batteries. Strictly follow the instructions in the User Manual.

## Updating the Firmware

To optimize the experience, it is recommended to keep the firmware of the aircraft, Intelligent Flight Batteries and remote controller up to date before each flight. Refer to the User Manual for instructions on updating the firmware to the latest version.

If the firmware update fails, restart the device and try again. Contact DJI Support if the issue persists.

## Pre-Flight Checklist

It is recommended to perform the following routine checks before each flight.

1. Use only genuine DJI parts and ensure all components are in good working condition.
2. Remote controller and aircraft batteries are fully charged.
3. Ensure all propellers are free of damage and wear, clean with no foreign objects, and properly installed on the motors.
4. Propellers and frame arms are unfolded and arm locks are firmly tightened.
5. Motors are mounted securely and start and function normally.
6. Landing gear, cargo case, and Intelligent Flight Battery are firmly in place.
7. All parts are mounted securely, and cables are connected correctly and firmly.
8. There is nothing obstructing the GNSS antennas, OCUSYNC™ antennas, FPV camera, Vision System, or the radar.
9. Make sure DJI Pilot 2 and the devices firmware have been updated to the latest version.
10. Make sure your flight area is outside any GEO zones, and flight conditions are suitable for flying the aircraft.
11. Make sure that you are not flying under the influence of alcohol, drugs, or any substance that may impair your cognitive abilities.
12. Be familiar with the selected flight mode. Be familiar with the aircraft action during Failsafe Return to Home (RTH).
13. Be sure to observe all local flight regulations. Obtain appropriate authorizations by yourself if necessary.
14. Ensure the DJI Pilot 2 App is running to assist your operation of the aircraft. Without having the flight data recorded by the DJI Pilot 2 App in certain situations (including the loss of your aircraft), DJI may not be able to provide aftersales support to you or assume liability.

# Inspection and Maintenance

Routine inspection before operations or regular maintenance can greatly improve the reliability of the aircraft, reduce potential safety hazards, and extend the service life of the aircraft.

Module	Inspection Part	Recommended Inspection Time	Recommended Maintenance Interval	Maintenance Frequency	Inspection Item	User Recommended Maintenance Suggestion
Propulsion System	Motors	<p>Routine Inspection: Pre-Flight Checklist for Every Day First Flight</p> <p>Regular Inspection:</p> <ol style="list-style-type: none"> <li>1. Perform the initial inspection after 100 flights.</li> <li>2. Interval for subsequent inspections: every 100 flight hours or every month of continuous operation.</li> </ol>	<p>Damaged: Replace immediately.</p> <p>Undamaged: Replace every 1000 flight hours or 36 months.</p>	Monthly Maintenance / Annual Maintenance	<ol style="list-style-type: none"> <li>1. Check if the motor internal resistance is normal.</li> <li>2. Check for broken wires and terminals in the motor.</li> <li>3. Check motor cover for damage.</li> <li>4. Check motor shaft for breakage.</li> <li>5. Check motor stator for damage.</li> <li>6. Check motor base and protective cover for damage.</li> <li>7. Check for abnormal noises in the motor.</li> </ol>	<ol style="list-style-type: none"> <li>1. Unfold the propellers and hold the tips of the left and right propellers with your hands. Shake up and down to check for rotor looseness. Replace if loose.</li> <li>2. Rotate the motor to check for any noticeable resistance. Replace if resistance is detected.</li> </ol> <p>* Check if the ESC indicates a stall or if the motor/ESC temperature is abnormal.</p>
Propulsion System	Propeller Adapters	<p>Routine Inspection: Pre-Flight Checklist for Every Day First Flight</p> <p>Regular Inspection:</p> <ol style="list-style-type: none"> <li>1. Perform the initial inspection after 100 flights.</li> <li>2. Interval for subsequent inspections: every 100 flight hours or every month of continuous operation.</li> </ol>	<p>Damaged: Replace immediately.</p> <p>Undamaged: Replace every 300 flight hours.</p>	Routine Maintenance / Monthly Maintenance / Annual Maintenance	Check propeller adapters (including adapter shaft and shaft nut) for damage.	<ol style="list-style-type: none"> <li>1. Check propeller adapters for any visible cracks.</li> <li>2. Check the nuts for any fluid accumulation and wipe if necessary.</li> <li>3. Check nuts for looseness using alignment marks. If loose, apply Loctite 243 and retighten to 52 kgf*cm.</li> <li>4. Replace if disassembled more than 3 times (up to 3 times allowed).</li> </ol>
Propulsion System	Electronic Speed Controller (ESC)	<p>Routine Inspection: Pre-Flight Checklist for Every Day First Flight</p> <p>Regular Inspection:</p> <ol style="list-style-type: none"> <li>1. Perform the inspection after 100 flights.</li> <li>2. Interval for subsequent inspections: every 100 flight hours or every month of continuous operation.</li> </ol>	<p>Damaged: Replace immediately.</p> <p>Undamaged: Replace every 1000 flight hours or 36 months.</p>	Annual Maintenance	<ol style="list-style-type: none"> <li>1. Clean and check for corrosion.</li> <li>2. Check for proper power-up and functionality.</li> <li>3. Check LED cover for damage.</li> </ol>	<ol style="list-style-type: none"> <li>1. Visual inspection.</li> <li>2. Check status on the DJI Pilot 2 App HMS page.</li> </ol>

<p>Propulsion System</p>	<p>Propellers</p>	<p>Routine Inspection: Before the first flight each day, inspect the propeller wear lines. During manual unfolding, also check for wear lines and adhere to the standards.</p> <p>Regular Inspection: 1. Perform the inspection after 100 flights. 2. Interval for subsequent inspections: every 50 flight hours or every half month of continuous operation.</p>	<p>Damaged: Replace immediately.</p> <p>Undamaged: Replace every 1000 flight hours or 36 months.</p>	<p>Monthly Maintenance / Annual Maintenance</p>	<ol style="list-style-type: none"> <li>1. Clean the propellers and check edges for cracks or deformation. Replace if cracks, deformation, or bulges are found.</li> <li>2. Check propeller wear line: Pull the propeller to inspect the wear line condition.</li> <li>3. Propeller Preload Inspection: Grasp the propeller tip and lift up or down to check for looseness. (Looseness occurs when the spacer at the propeller root loses preload, resulting in a loose propeller root.) If loose, remove and inspect the propeller and spacer. Replace the propeller if you notice any of the following:             <ol style="list-style-type: none"> <li>① Small cracks at the propeller hole edge.</li> <li>② The propeller hole is worn into an oval shape (refer to wear line standards for failure criteria).</li> </ol> <p>For spacer replacement criteria, refer to the inspection method for propeller spacer.</p> </li> <li>4. Use an 11mm wrench to tighten the nut, with a recommended torque of 52 kgf*cm.</li> </ol>
<p>Propulsion System</p>	<p>Propeller Spacers</p>	<p>Regular Inspection: 1. Perform the inspection after 100 flights. 2. Interval for subsequent inspections: every 50 flight hours or every half month of continuous operation.</p>	<p>Damaged: Replace immediately.</p> <p>Undamaged: Replace every 300 flight hours.</p>	<p>Routine Maintenance / Monthly Maintenance / Annual Maintenance</p>	<ol style="list-style-type: none"> <li>1. Grasp the propeller tip and lift up or down to check for looseness. (Looseness occurs when the spacer at the propeller root loses preload, resulting in a loose propeller root.) If loose:             <ol style="list-style-type: none"> <li>(1) Secure the M7 nut: Use an 11mm wrench to tighten the nut with a recommended torque of 52 kgf*cm. If this resolves the issue, no further action is needed; if not, proceed to step (2).</li> <li>(2) Replace the propeller spacer and use an 11mm wrench to tighten the nut with a recommended torque of 52 kgf*cm.</li> </ol> </li> <li>2. Check the propeller spacer for wear.</li> </ol>

Propulsion System	Frame Arm Bolts	<p>Routine Inspection: Pre-Flight Checklist for Every Day First Flight</p> <p>Regular Inspection:</p> <ol style="list-style-type: none"> <li>1. Perform the inspection after 100 flights.</li> <li>2. Every 50 flight hours or 100 flights.</li> </ol>	<p>Damaged: Replace immediately.</p> <p>Undamaged: Replace every 1000 flight hours or 36 months.</p>	Monthly Maintenance / Annual Maintenance	Each arm base has one arm bolt (four in total); check for deflection gaps or excessive play in the arm folding.	With the arm lock unsecured, slowly fold the arm back and forth, observing for any looseness or excessive gaps at the folding point.
Propulsion System	arm motor mount coating	<p>Regular Inspection:</p> <ol style="list-style-type: none"> <li>1. Perform the inspection after 100 flights.</li> <li>2. Every 50 flight hours or 100 flights.</li> </ol>	<p>Damaged: Replace immediately.</p> <p>Undamaged: Replace every 1000 flight hours or 36 months.</p>	Monthly Maintenance / Annual Maintenance	<ol style="list-style-type: none"> <li>1. Remove the motor and check the motor mount coating for deformation or wear.</li> <li>2. Check the motor mount coating for looseness.</li> </ol>	Visual inspection.
Propulsion System	Arm Carbon Tube	<p>Routine Inspection: Pre-Flight Checklist for Every Day First Flight</p> <p>Regular Inspection:</p> <ol style="list-style-type: none"> <li>1. Perform the inspection after 100 flights.</li> <li>2. Every 50 flight hours or 100 flights.</li> </ol>	<p>Damaged: Replace immediately.</p> <p>Undamaged: Replace every 1000 flight hours or 36 months.</p>	Monthly Maintenance / Annual Maintenance	<ol style="list-style-type: none"> <li>1. Check the arm carbon tube for cracks or wear.</li> <li>2. Check the arm carbon tube for bending.</li> </ol>	Visual inspection.
Propulsion System	Arm Rubber Coating Part	<p>Routine Inspection: Pre-Flight Checklist for Every Day First Flight</p> <p>Regular Inspection:</p> <ol style="list-style-type: none"> <li>1. Perform the inspection after 100 flights.</li> <li>2. Every 50 flight hours or 100 flights.</li> </ol>	<p>Damaged: Replace immediately.</p> <p>Undamaged: Replace every 1000 flight hours or 36 months.</p>	Monthly Maintenance / Annual Maintenance	<ol style="list-style-type: none"> <li>1. Check the arm rubber coating part for cracks or wear.</li> <li>2. Check the arm rubber coating part for deformation.</li> <li>3. Check the air-frame lock handle for damage or missing parts.</li> </ol>	Visual inspection.
Aircraft Structural Parts	Arm Connector	<p>Routine Inspection: Pre-Flight Checklist for Every Day First Flight</p> <p>Regular Inspection:</p> <ol style="list-style-type: none"> <li>1. Perform the inspection after 100 flights.</li> <li>2. Every 50 flight hours or 100 flights.</li> </ol>	<p>Damaged: Replace immediately.</p> <p>Undamaged: Replace every 1000 flight hours or 36 months.</p>	Monthly Maintenance / Annual Maintenance	Check the connectors of M1~4 arms for deformation or cracks.	Visually inspect the connector for any cracks or deformation.

Aircraft Structural Parts	Battery Support Parts	Regular Inspection: Replace after 2000 insertions or inspect every month.	Damaged: Replace immediately. Undamaged: Replace every 1000 flight hours or 36 months.	Monthly Maintenance / Annual Maintenance	Check if the slider on the battery support part is worn or sticking.	Visually inspect the battery support part for deformation or sticking.
Aircraft Structural Parts	Arm Fixture Screws	Routine Inspection: Pre-Flight Checklist for Every Day First Flight Regular Inspection: 1. Perform the inspection after 100 flights. 2. Every 50 flight hours or 100 flights.	Damaged: Replace immediately. Undamaged: Replace every 1000 flight hours or 36 months.	Monthly Maintenance / Annual Maintenance	The aircraft body has a total of four arm fixtures, with each arm fixture having 16 screws, making a total of 64 screws. 1. Check if the screws are loose. 2. Check if the screws are broken.	Slightly move the front and rear frames to check for looseness.
Aircraft Structural Parts	Radar Mounting Bracket	Regular Inspection: Every 300 flight hours.	Damaged: Replace immediately. Undamaged: Replace every 1000 flight hours or 36 months.	Monthly Maintenance / Annual Maintenance	Check the radar mounting bracket screws and nearby screws, totaling 6 screws. 1. Check if the screws are loose. 2. Check if the screws are broken.	Slightly move and pull the radar to check for any displacement or looseness.
Aircraft Structural Parts	Aircraft Connector	Regular Inspection: Every 300 flight hours.	Damaged: Replace immediately. Undamaged: Replace every 1000 flight hours or 36 months.	Monthly Maintenance / Annual Maintenance	1. Check the power distribution board and cable distribution board connectors for looseness or corrosion. 2. Check for cable interference or excessive bending. 3. Check the in-position detection bracket for damage or missing parts.	1. Visual inspection. 2. Check status on the DJI Pilot 2 App HMS page.
Aircraft Structural Parts	Front Frame	Routine Inspection: Pre-Flight Checklist for Every Day First Flight Regular Inspection: Every 300 flight hours.	Damaged: Replace immediately. Undamaged: Replace every 1000 flight hours or 36 months.	Annual Maintenance	1. Check for cracks or damage. 2. Check for any looseness in the structure.	Visual inspection.
Aircraft Structural Parts	Rear Frame	Routine Inspection: Pre-Flight Checklist for Every Day First Flight Regular Inspection: Every 300 flight hours.	Damaged: Replace immediately. Undamaged: Replace every 1000 flight hours or 36 months.	Annual Maintenance	1. Check for cracks or damage. 2. Check for any looseness in the structure.	Visual inspection.

Aircraft Structural Parts	Middle Frame	Routine Inspection: Pre-Flight Checklist for Every Day First Flight Regular Inspection: Every 300 flight hours.	Damaged: Replace immediately. Undamaged: Replace every 1000 flight hours or 36 months.	Annual Maintenance	1. Check for cracks or damage. 2. Check for any looseness in the structure.	Visual inspection.
Landing Gear Structural Components	Securing Screw	Routine Inspection: Pre-Flight Checklist for Every Day First Flight Regular Inspection: 1. Perform the inspection after 100 flights. 2. Every 50 flight hours or 100 flights.	Damaged: Replace immediately. Undamaged: Replace every 1000 flight hours or 36 months.	Monthly Maintenance / Annual Maintenance	Landing gear securing screws: 10 per side, totaling 20 screws. 1. Check for loose screws. 2. Check for broken screws.	Slightly move and pull the landing gear to check for any displacement or looseness.
Remote Controller	Remote Controller	Routine Inspection: Check before each flight.	Damaged: Replace immediately. Undamaged: Replace every 1000 flight hours or 36 months.	Monthly Maintenance / Annual Maintenance	Check remote controller appearance.	1. Visual inspection. 2. Check status on the DJI Pilot 2 App HMS page.
Remote Controller	Remote Controller External Battery	Routine Inspection: Check before each flight.	Damaged: Replace immediately. Undamaged: Replace every 1000 flight hours or 36 months.	Annual Maintenance	1. Check the battery casing for damage, dents, or swelling. 2. Check the battery charging port pins for deformation or corrosion.	1. Visual inspection. 2. Check status on the DJI Pilot 2 App HMS page.
Flight Battery	Standard Included Battery	Routine Inspection: Pre-Flight Checklist for Every Day First Flight Regular Inspection: 1. It is recommended to inspect the battery every 1500 cycles (as shown in the app). 2. Inspect the battery charging port and power button after a total of 1500 flights.	Damaged: Replace immediately. Undamaged: Replace when the app shows health below 80% or after 36 months, whichever is reached first.	Monthly Maintenance / Annual Maintenance	1. Check for swelling, dents, or deformation. 2. Clean the battery charging port. 3. Fully charge and discharge the battery at least once every three months to ensure the performance of the battery.	Clean the exterior of the battery charging port with a cotton swab dipped in alcohol with a concentration of 95% or higher.

Charger	Charger	Regular Inspection: Every 300 flight hours.	Damaged: Replace immediately.  Undamaged: Replace every 1000 flight hours or 36 months.	Monthly Maintenance / Annual Maintenance	<ol style="list-style-type: none"> <li>1. Check for any bumps or impacts.</li> <li>2. Check if the battery charging port is dirty.</li> <li>3. Clean the cooling fan.</li> </ol>	<ol style="list-style-type: none"> <li>1. Visually inspect the casing for dirt or grime.</li> <li>2. Use alcohol with a concentration of 95% or higher to clean the battery interface.</li> </ol>
Sensing and obstacle avoidance system	Front/Rear Radar	Regular Inspection: Every 300 flight hours.	Damaged: Replace immediately.  Undamaged: Replace every 1000 flight hours or 36 months.	Annual Maintenance	<ol style="list-style-type: none"> <li>1. Check the exterior for dents or other damage from external forces.</li> <li>2. Clean and check the port for corrosion.</li> <li>3. Check for proper power-up and functionality.</li> </ol>	<ol style="list-style-type: none"> <li>1. Visual inspection.</li> <li>2. Check status on the DJI Pilot 2 App HMS page.</li> </ol>
Sensing and obstacle avoidance system	Binocular Vision Module	Regular Inspection: Every 300 flight hours.	Damaged: Replace immediately.  Undamaged: Replace every 1000 flight hours or 36 months.	Annual Maintenance	<ol style="list-style-type: none"> <li>1. Visually inspect the binocular vision module for deformation, damage, or dirt.</li> <li>2. Check for looseness or corrosion in the binocular vision signal cable.</li> </ol>	<ol style="list-style-type: none"> <li>1. Visual inspection.</li> <li>2. Check status on the DJI Pilot 2 App HMS page.</li> </ol>
Wireless Communication System (Video Transmission System)	RF module	Regular Inspection: Every 300 flight hours.	Damaged: Replace immediately.  Undamaged: Replace every 1000 flight hours or 36 months.	Annual Maintenance	<ol style="list-style-type: none"> <li>1. Clean and check for corrosion.</li> <li>2. Check for proper power-up and functionality.</li> </ol>	Check status on the DJI Pilot 2 App HMS page.
Wireless Communication System (Video Transmission System)	SDR Antenna	Regular Inspection: Every 300 flight hours.	Damaged: Replace immediately.  Undamaged: Replace every 1000 flight hours or 36 months.	Annual Maintenance	<ol style="list-style-type: none"> <li>1. Clean and check for corrosion.</li> <li>2. Check for proper power-up and functionality.</li> </ol>	<ol style="list-style-type: none"> <li>1. Visual inspection.</li> <li>2. Check status on the DJI Pilot 2 App HMS page.</li> </ol>
Wireless Communication System (Video Transmission System)	Cellular Dongle	Regular Inspection: Every 300 flight hours.	Damaged: Replace immediately.  Undamaged: Replace every 1000 flight hours or 36 months.	Annual Maintenance	Check the cellular dongle for any deformation and the interface for corrosion.	<ol style="list-style-type: none"> <li>1. Visual inspection.</li> <li>2. Check status on the DJI Pilot 2 App HMS page.</li> </ol>

Flight Control and Navigation System	Avionics Module	Regular Inspection: Every 300 flight hours.	Damaged: Replace immediately. Undamaged: Replace every 1000 flight hours or 36 months.	Annual Maintenance	<ol style="list-style-type: none"> <li>Clean and check for corrosion.</li> <li>Check for proper power-up and functionality.</li> </ol>	Check status on the DJI Pilot 2 App HMS page.
Flight Control and Navigation System	RTK Module	Regular Inspection: Every 300 flight hours.	Damaged: Replace immediately. Undamaged: Replace every 1000 flight hours or 36 months.	Annual Maintenance	<ol style="list-style-type: none"> <li>Clean and check for corrosion.</li> <li>Check for proper power-up and functionality.</li> </ol>	<ol style="list-style-type: none"> <li>Visual inspection.</li> <li>Check status on the DJI Pilot 2 App HMS page.</li> </ol>
Electrical System	Cable Distribution Board Module	Regular Inspection: Every 300 flight hours.	Damaged: Replace immediately. Undamaged: Replace every 1000 flight hours or 36 months.	Annual Maintenance	<ol style="list-style-type: none"> <li>Clean and check for corrosion.</li> <li>Check for proper power-up and functionality.</li> </ol>	Check status on the DJI Pilot 2 App HMS page.
Electrical System	Payload Control Module	Regular Inspection: Every 300 flight hours.	Damaged: Replace immediately. Undamaged: Replace every 1000 flight hours or 36 months.	Annual Maintenance	<ol style="list-style-type: none"> <li>Clean and check for corrosion.</li> <li>Check for proper power-up and functionality.</li> </ol>	Check status on the DJI Pilot 2 App HMS page.
Electrical System	Avionics Module (Front and Rear)	Regular Inspection: Every 300 flight hours.	Damaged: Replace immediately. Undamaged: Replace every 1000 flight hours or 36 months.	Annual Maintenance	<ol style="list-style-type: none"> <li>Clean and check for corrosion.</li> <li>Check for proper power-up and functionality.</li> </ol>	Check the power distribution board interface for dirt, and clean with alcohol of 95% concentration or higher.
Cargo System	Cargo System Weight Sensor	Regular Inspection: Every 300 flight hours.	Damaged: Replace immediately. Undamaged: Replace every 1000 flight hours or 36 months.	Monthly Maintenance / Annual Maintenance	<ol style="list-style-type: none"> <li>Check the weight sensors (4 in total, mounted on the frame) for wear or broken cables.</li> <li>Check the weight module cables for disconnections or loose connections.</li> </ol>	Visual inspection.
Cargo System	Cargo Case Components	Regular Inspection: Every 300 flight hours.	Damaged: Replace immediately. Undamaged: Replace every 1000 flight hours or 36 months.	Annual Maintenance	<ol style="list-style-type: none"> <li>Check the cargo case for deformation or cracks.</li> <li>Check for deformation in the cargo case door spring and damage to the door handle.</li> </ol>	Visual inspection.

Cargo System	Cargo Case Weight Sensor Bracket	Regular Inspection: 1. Perform the inspection after 100 flights. 2. Every 100 flight hours or 1 month.	Damaged: Replace immediately. Undamaged: Replace every 1000 flight hours or 36 months.	Monthly Maintenance / Annual Maintenance	1. Check the weight sensor bracket for deformation or damage. 2. Check the weight sensor signal cable interface for corrosion or looseness.	1. Visual inspection. 2. Check status on the DJI Pilot 2 App HMS page.
FPV System	FPV Components	Regular Inspection: Every 300 flight hours.	Damaged: Replace immediately. Undamaged: Replace every 1000 flight hours or 36 months.	Annual Maintenance	1. Visually inspect the FPV for deformation, damage, or dirt. 2. Check if FPV signal cable is loose or has been eroded	1. Visual inspection. 2. Check status on the DJI Pilot 2 App HMS page.
Parachute System	Parachute Components	Undeployed parachute: Inspect and maintain annually. Deployed parachute: Replace with a new parachute promptly.	Undeployed: and damaged parachute: Replace immediately. Undeployed: and undamaged parachute: Replace every 3 years. Deployed parachute: Replace immediately.	Annual Maintenance	1. Check the parachute for deformation or cracks. 2. Check the parachute control box for damaged lights and buttons, and inspect the signal cable for cracks. 3. Check the parachute securing screws for looseness. 4. Check for looseness or detachment of the parachute cover.	1. Visual inspection. 2. Check status on the DJI Pilot 2 App HMS page.
Landing Gear Structural Components	Landing Gear Components	Routine Inspection: Pre-Flight Checklist for Every Day First Flight Regular Inspection: 1. Perform the inspection after 100 flights. Checking the Result 2. Interval for subsequent inspections: every 100 flight hours or every month of continuous operation.	Damaged: Replace immediately. Undamaged: Replace every 1000 flight hours or 36 months.	Routine Maintenance/ Monthly Maintenance/ Annual Maintenance	1. Check the bottom of the landing gear for wear. 2. Check the landing gear aluminum tubes and the front and rear crossbars for bending or deformation.	1. Visual inspection.
Whole Aircraft	Whole Aircraft	Regular Inspection: It is recommended to perform a full maintenance check of the entire aircraft every 500 flight hours or annually, based on whichever is reached first.	Undamaged: Replace every 1000 flight hours or 36 months.	Annual Maintenance	Perform maintenance and inspection according to the above items.	1. Visual inspection. 2. Check status on the DJI Pilot 2 App HMS page.

## Battery Maintenance

To minimize the impact of battery aging on performance, it is recommended to perform the following actions on the battery every 200 cycles or every three months:



### Checklist for Maintenance

Maintenance is required when any of the events below occur:

- Charge and discharge the battery as per instructions.
- Insert the battery into the aircraft and power on to view the battery information in DJI Pilot 2. Make sure the difference in cell voltage is less than 0.1 V and that the battery firmware is updated to the latest version.
- The battery is not swollen, leaky, or damaged.
- Check the battery connector for dirt or damage.

### Battery Replacement Standard

- The battery is visibly swollen, leaky, or damaged.
- It is not recommended to continue using the battery after 1500 cycles.
- The battery error still exists after performing the standard charge and discharge operations twice continuously.

## Battery Disposal

- ⚠ • Before disposing, make sure to soak the battery in water for 72 hours to completely discharge the battery. Dispose of the battery in specific recycling boxes. The battery contains hazardous chemicals, DO NOT dispose of the battery in a regular waste disposal container. Strictly follow your local regulations regarding the disposal and recycling of batteries.
- If the battery cannot be discharged completely, DO NOT dispose of the battery in a battery recycling box directly. Contact a professional battery recycle company for assistance.

## Battery Usage Notes

- DO NOT charge the battery near flammable materials or objects or on flammable surfaces.
- DO NOT use the battery in a humid environment to avoid short circuit.
- DO NOT disassemble or pierce the battery in any way.
- Store the battery in a well-ventilated and dry place.
- Initiate RTH immediately when the app prompts that the battery temperature is too high.

## Firmware Update and System Calibration

It is recommended to update the firmware of the aircraft and the remote controller in time and to perform calibration regularly to keep the aircraft in its best condition.

No.	Tab
1	Aircraft firmware update
2	Remote controller firmware update
3	Charging hub firmware update
4	IMU Calibration
5	Compass calibration

# Health Management System (HMS)

View the status of each module and upload abnormal status logs on the Health Management System (HMS) page in DJI Pilot 2.

1. Enter the HMS page in DJI Pilot 2.

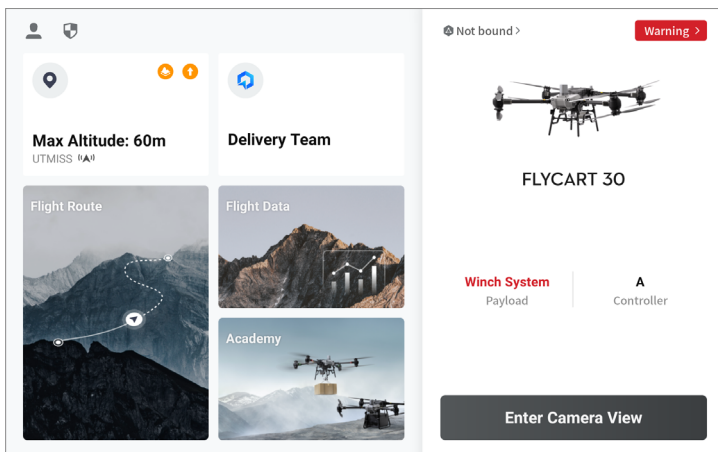

2. View the condition of each module of the connected device.

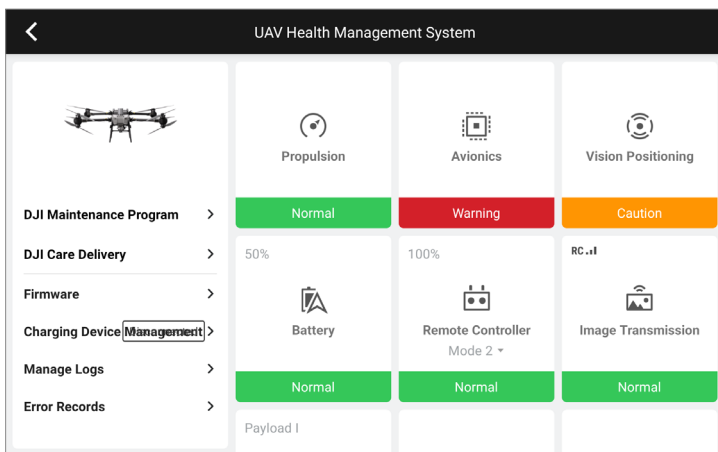

3. If any module is abnormal, tap to view the warning message.

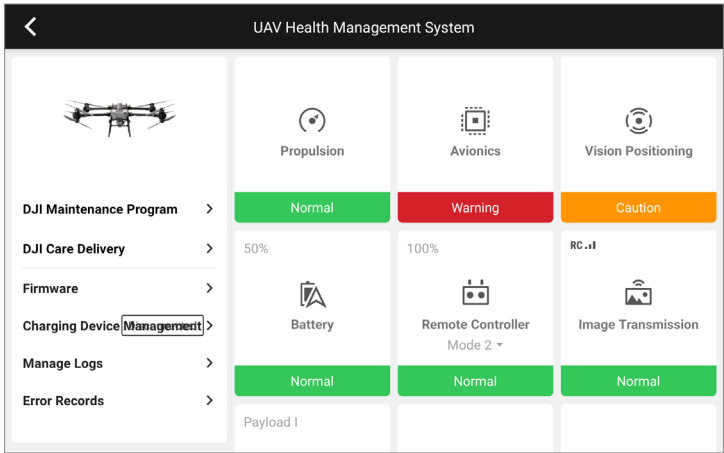

4. Tap the warning message to view the help document for troubleshooting. If the abnormal status still exists after troubleshooting, users can upload the log and send the QR code or the tracking number to DJI Support for help.

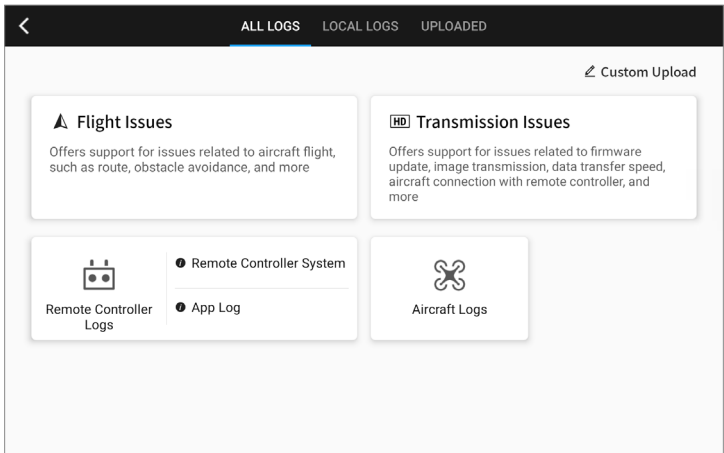

Manage Logs			
Relevant Logs (101):			
Log Name	On/Off Time	Time Period	
FC30_Flight Issues_20250205153835	2025-02-05 15:36:24 2025-02-05 15:38:35	00:02:11	<input type="radio"/>
FC30_Flight Issues_20250205135701	2025-02-05 13:45:31 2025-02-05 13:57:01	00:11:30	<input type="radio"/>
FC30_Flight Issues_20250205134530	2025-02-05 13:25:31 2025-02-05 13:45:30	00:19:59	<input type="radio"/>
FC30_Flight Issues_20250205132531	2025-02-05 13:05:31 2025-02-05 13:25:31	00:20:00	<input type="radio"/>
FC30_Flight Issues_20250205130530	2025-02-05 12:45:31	00:19:59	<input type="radio"/>

**Log uploaded. Thanks for your feedback!**

You may submit this QR code or this confirmation number to Customer Service for follow-up actions.

**625d2243-8a47-4bb5-91fa-6dd0162d4b62**

Remote Controller System

On/Off Time:2025-02-05 12:10:47-2025-02-05 12:14:25

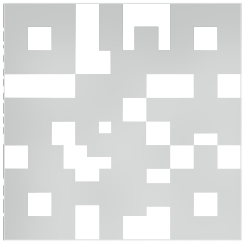

Cancel      Save QR Code      **UPLOAD**

Log	Time Period	
RM700_Rem System_2025	00:11:55	<input type="radio"/>
RM700_Rem System_2025	00:03:38	<input checked="" type="radio"/>
RM700_Rem System_2025	00:15:22	<input type="radio"/>
RM700_Rem System_2025	05:55:33	<input type="radio"/>

(1) Selected

5. At the same time, go to log management and select the aircraft, remote controller, and charging hub\* with abnormal flights to upload logs according to the log deadline.

\* The charging hub USB-C port must be connected to the remote controller USB-A port by using a cable when exporting the charging hub log.

# DJI Maintenance Program

1. Enter the HMS page in DJI Pilot 2.

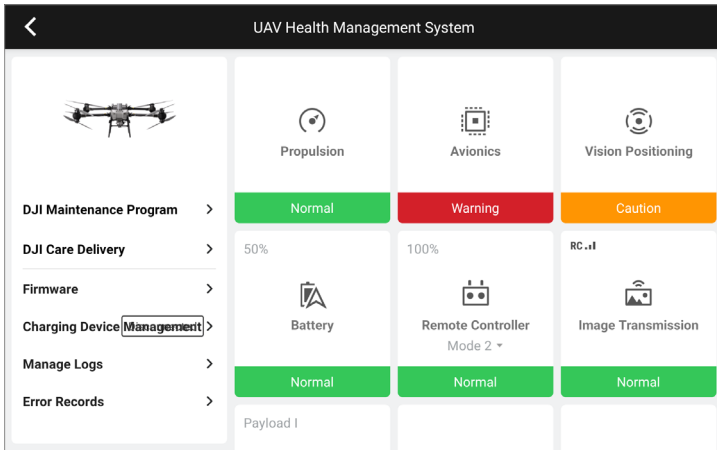

2. View the flight data and maintenance items of the current devices.

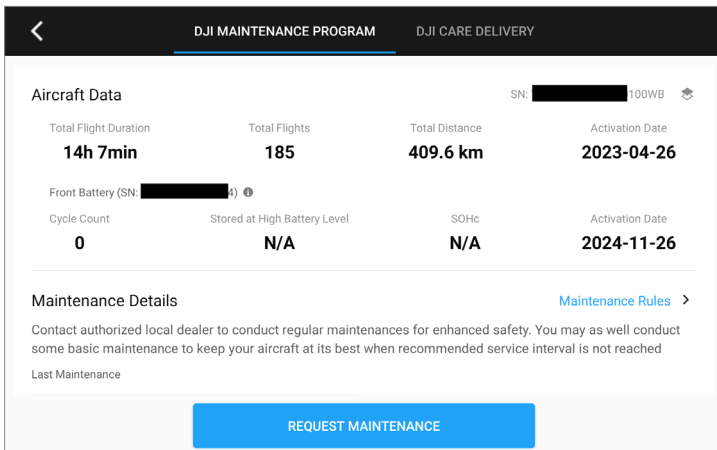

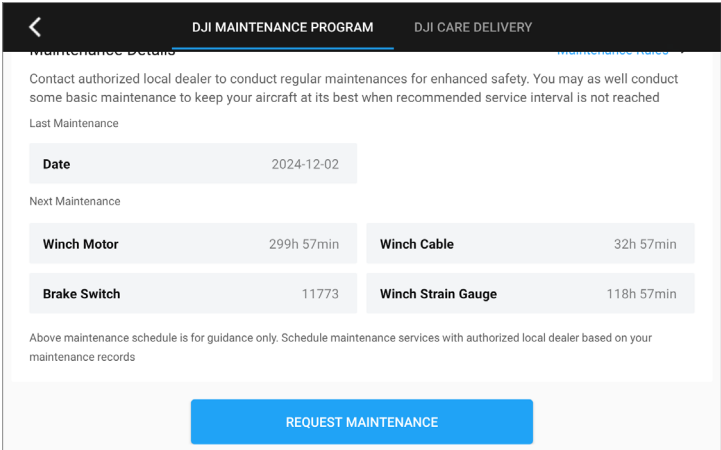

- When the conditions for maintenance service are met, it is recommended to tap Request Maintenance, which will redirect you to the official after-sales service phone number. Tap Maintenance Application to initiate the maintenance process.

# DJI Drone Maintenance Service - DJI FC 30 Winch System Maintenance Guidelines

## Compatible Aircraft Models

DJI FC 30 Winch System

## Maintenance Rules

Module	Inspection Part	Recommended Inspection Time	Recommended Maintenance Interval	Maintenance Frequency	Inspection Item	User Recommended Maintenance Suggestion
Winch System	Winch Cable	Regular Inspection: Winch motor operating time: 33 hours.	Damaged: Replace immediately. Undamaged: Winch motor operating time: 100 hours.	Routine Maintenance / Monthly Maintenance / Annual Maintenance	Evaluate the cable condition based on the motor operating time to determine if replacement is necessary. Conditions for cable replacement: Severe wear (more than half worn, diameter less than 1.5mm) or significant fraying (fraying over 4mm).	Visual inspection.
Winch System	Winch System Rope Sleeve	Regular Inspection: Winch motor operating time: 33 hours.	Damaged: Replace immediately. Undamaged: Winch motor operating time: 100 hours.	Monthly Maintenance / Annual Maintenance	1. Check the rope sleeve for deformation or wear. 2. Check for looseness in the retaining clip on the center shaft of the rope seat.	Visual inspection.
Winch System	Winch System Gear Reducer	Regular Inspection: Winch motor operating time: 33 hours.	Damaged: Replace immediately. Undamaged: Winch motor operating time: 100 hours.	Monthly Maintenance / Annual Maintenance	1. Disassemble the gear reducer and check for deformation or wear. 2. Check for misalignment in the center hole of the gear reducer.	1. Visual inspection. 2. Check status on the DJI Pilot 2 App HMS page.
Winch System	Winch System Hook Assembly	Regular Inspection: Perform the inspection after 1500 flights.	Damaged: Replace immediately. Undamaged: Replace every 1000 flight hours or 36 months.	Daily Maintenance / Monthly Maintenance / Annual Maintenance	1. Check if the secondary lock of the winch hook opens and closes properly. 2. Check if the torsion spring of the winch hook has normal tension. 3. Check the winch hook for any deformation.	Visual inspection.

Winch System	Winch System Motor	Regular Inspection: Winch motor operating time: 300 hours.	Damaged: Replace immediately.  Undamaged: Replace every 1000 flight hours or 36 months.	Monthly Maintenance / Annual Maintenance	<ol style="list-style-type: none"> <li>1. Check for looseness in the motor shaft.</li> <li>2. Clean the grease from the motor gearbox, especially from the gear gaps, and apply new grease.</li> </ol>	<ol style="list-style-type: none"> <li>1. Visual inspection.</li> <li>2. Check status on the DJI Pilot 2 App HMS page.</li> </ol>
Winch System	Winch System Brake	Regular Inspection: Number of brake operations: 12000 times.	Damaged: Replace immediately.  Undamaged: Replace every 1000 flight hours or 36 months.	Annual Maintenance	<ol style="list-style-type: none"> <li>1. Check if the brake pads need replacement.</li> <li>2. Clean the powder around the brake, especially in the small gaps on the coil.</li> </ol>	<ol style="list-style-type: none"> <li>1. Visual inspection.</li> <li>2. Check status on the DJI Pilot 2 App HMS page.</li> </ol>
Winch System	Winch System Control Box	Regular Inspection: Winch motor operating time: 300 hours.	Damaged: Replace immediately.  Undamaged: Replace every 1000 flight hours or 36 months.	Annual Maintenance	<ol style="list-style-type: none"> <li>1. Check the appearance for cracks, damages, and deformation.</li> <li>2. Check all the connector pins in the control box for corrosion or deformation.</li> </ol>	<ol style="list-style-type: none"> <li>1. Visual inspection.</li> <li>2. Check status on the DJI Pilot 2 App HMS page.</li> </ol>
Winch System	Winch System Weight Module	Routine Inspection: Pre-Flight Checklist for Every Day First Flight  Regular Inspection: Winch motor operating time: 120 hours.	Damaged: Replace immediately.  Undamaged: Replace every 1000 flight hours or 36 months.	Monthly Maintenance / Annual Maintenance	<ol style="list-style-type: none"> <li>1. Check the appearance for cracks, damages, and deformation.</li> <li>2. Check if the weight value displayed on the remote controller matches the actual weight.</li> <li>3. Perform tare calibration and weight calibration for the weight sensors.</li> </ol>	<ol style="list-style-type: none"> <li>1. Visual inspection.</li> <li>2. Check status on the DJI Pilot 2 App HMS page.</li> </ol>
Winch System	Winch System Carbon Tube	Routine Inspection: Pre-Flight Checklist for Every Day First Flight  Regular Inspection: <ol style="list-style-type: none"> <li>1. Perform the inspection after 100 flights.</li> <li>2. Total flight time is 100 hours, or the product has been used for 1 months.</li> </ol>	Damaged: Replace immediately.  Undamaged: Replace every 1000 flight hours or 36 months.	Monthly Maintenance / Annual Maintenance	<ol style="list-style-type: none"> <li>1. Check the winch system carbon tube for deformation or damage.</li> <li>2. Check for looseness in the securing screws of the winch system carbon tube.</li> </ol>	Visual inspection.

Winch System	Winch System Middle Frame (including side panels)	<p>Routine Inspection: Pre-Flight Checklist for Every Day First Flight</p> <p>Regular Inspection: 1. Perform the inspection after 100 flights.</p> <p>Total flight time is 100 hours, or the product has been used for 1 months.</p>	<p>Damaged: Replace immediately.</p> <p>Undamaged: Replace every 1000 flight hours or 36 months.</p>	Monthly Maintenance / Annual Maintenance	<ol style="list-style-type: none"> <li>1. Check the winch system middle frame for wear or deformation.</li> <li>2. Check the winch system middle frame for cracks and misalignment of the center hole.</li> </ol>	Visual inspection.
Landing Gear Structural Components	Landing Gear Components	<p>Routine Inspection: Pre-Flight Checklist for Every Day First Flight</p> <p>Regular Inspection: 1. Perform the inspection after 100 flights.</p> <p>Total flight time is 100 hours, or the product has been used for 1 months.</p>	<p>Damaged: Replace immediately.</p> <p>Undamaged: Replace every 1000 flight hours or 36 months.</p>	Routine Maintenance/ Monthly Maintenance Annual Maintenance	<ol style="list-style-type: none"> <li>1. Check the bottom of the four landing gear extension rods for wear and the screw holes for looseness.</li> <li>2. Check the winch system landing gear and the front and rear crossbars for bending or deformation.</li> </ol>	Visual inspection.

## FAQ

1. How can I tell if my machine needs maintenance?

The maintenance service module in the DJI Pilot 2 App will notify you with a "Maintenance Needed" alert and highlight it in yellow when your aircraft requires maintenance.

---

This content is subject to change without prior notice.

Download the latest version from



<https://www.dji.com/flycart-30/downloads>

If you have any questions about this document, contact DJI by sending a message to [DocSupport@dji.com](mailto:DocSupport@dji.com).